

# CASSETTE

FLUSH CISTERNS - RESERVOIR DE CHASSE

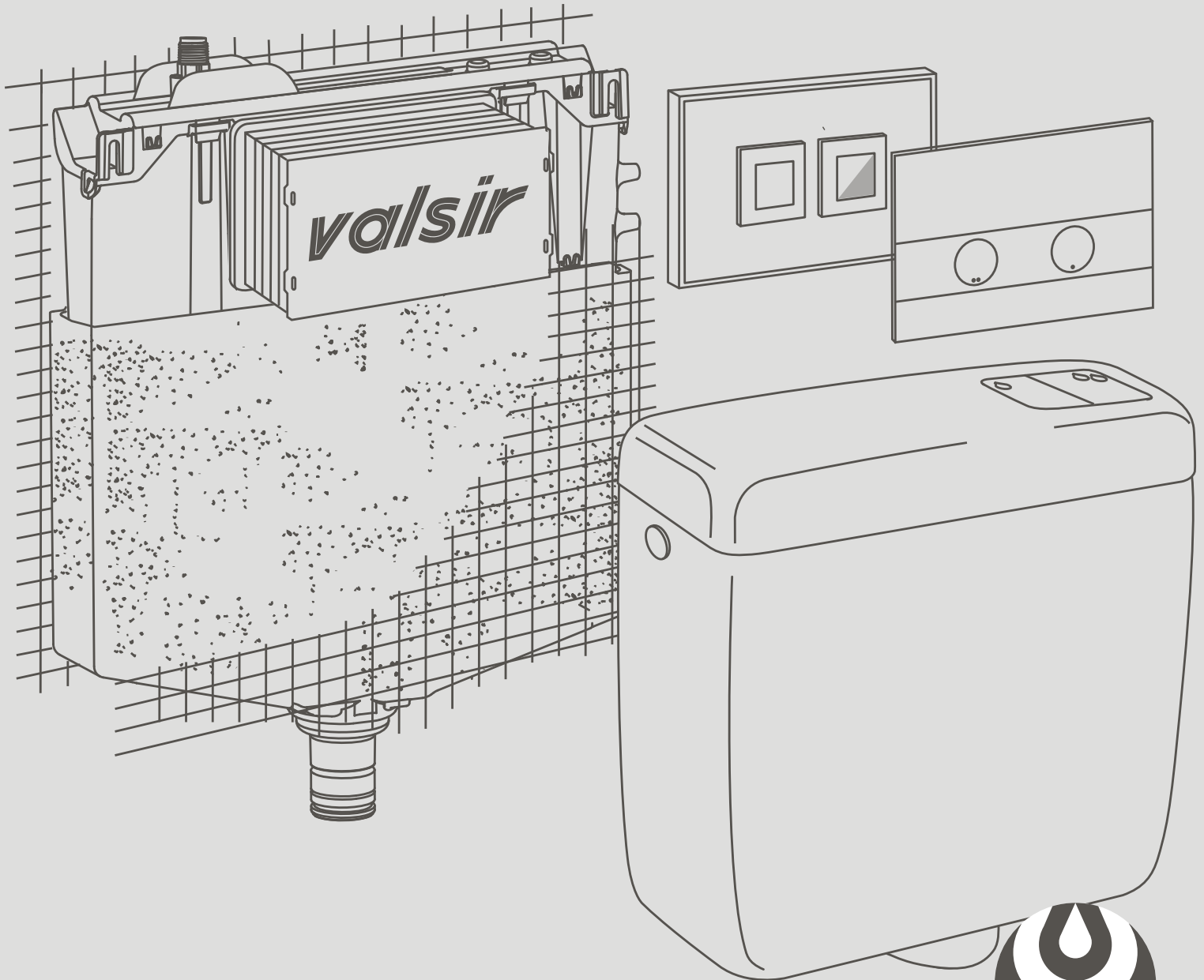

## Cassette di risciacquo a incasso ed esterne

*In-wall and exposed flush cisterns*

*Réservoir de chasse apparent et à encastrer*

MADE IN ITALY

CATALOGO  
CATALOGUE - CATALOGUE  
L02-780/0

**valsir**<sup>®</sup>  
QUALITY FOR PLUMBING

## **CASSETTE INCASSO** **IN-WALL FLUSH CISTERN - RÉSERVOIR À ENCASTRER** **3**

---

TROPEA S	3
WINNER S	11
CUBIK S	29

---

## **PLACCHE E COMANDI** **PUSH PLATES - PLAQUES ET COMMANDES VALSIR** **37**

---

Placche di comando meccaniche e pneumatiche <i>Mechanic and pneumatic push plates - Plaques de commande mécaniques et pneumatiques</i>	41
Placche di comando elettroniche <i>Electronic push plates - Plaques de commande électroniques</i>	47
Placche di comando pneumatiche Valsir Design <i>Valsir design pneumatic push plates - Valsir design plaques de commande pneumatique</i>	49
Placche di comando large (245x165 mm) <i>Large (245x165 mm) push plates - Plaques de commande large (245x165 mm)</i>	64
Comandi pneumatici non ingombro <i>Space-saving pneumatic actuators - Commandes pneumatiques faible encombrement</i>	66
Comandi pneumatici per ipovedenti <i>Pneumatic actuators for the partially sighted - Commandes pneumatiques pour malvoyants</i>	69
Comandi pneumatici universali <i>universal pneumatic actuators - commandes pneumatiques universelles</i>	70
Cannotti <i>Connectors - Tubes de raccordement cuvette</i>	74

---

## **STRUTTURE** **MOUNTING FRAMES - STRUCTURES** **77**

---

Strutture Fixsystem <i>Fixsystem metal mounting frames - Structures Fixsystem</i>	78
Strutture Block <i>Block mounting frames - Structures Block</i>	79
Strutture Block autoportanti <i>Free-standing Block frames - Structures Block autoportant</i>	85

---

## **ACCESSORI CASSETTE E STRUTTURE** **ACCESSORIES FOR CISTERNS AND FRAMES - ACCESSOIRES POUR RÉSERVOIR ET STRUCTURES** **87**

---

## **CASSETTE ESTERNE** **EXPOSED FLUSH CISTERNS - RÉSERVOIR APPARENT** **97**

---





## **RICAMBI** **SPARE PARTS - PIÈCES DE RECHANGE** **117**

---

## **ACCESSORI E RICAMBI PER PRODUZIONI FINO AL 2015** **ACCESSORIES AND SPARE PARTS FOR PRODUCTION UP TO 2015** **ACCESSOIRES ET PIÈCES DE RECHANGE POUR PRODUITS FINIS EN 2015** **153**

---

LEGENDA  
LEGEND  
LÉGENDE

Abbreviazioni <i>Abbreviations</i> <i>Abréviations</i>	Unità di misura <i>Measurement units</i> <i>Unité de mesure</i>	Descrizione <i>Description</i> <i>Désignation</i>
€/pz	-	Prezzo per singolo pezzo - <i>Price per piece</i> - <i>Prix unitaire, poids</i>
COD.	-	Codice dell'articolo - <i>Item code</i> - <i>Référence de l'article</i>
CL	-	Classe di sconto - <i>Discount category</i> - <i>Groupe produit</i>
D	mm	Diametro - <i>Diameter</i> - <i>Diamètre</i>
DN	mm	Diametro nominale - <i>Nominal diameter</i> - <i>Diamètre nominale</i>
	n°	Pezzi per scatola - <i>Pieces per pack</i> - <i>Prix par conditionnement</i>
	n°	Scatole in scatoloni - <i>Boxes per outer box</i>
	n°	Pezzi per ripiano bancale - <i>Pieces per pallet layer</i> - <i>Pièce par surpalette</i>
	n°	Pezzi per bancale - <i>Pieces per pallet</i> - <i>Pièces par palette</i>
HxLxP 	mm	Dimensioni bancale - <i>Pallet dimensions</i> - <i>Dimensions de la palette</i>
$\alpha$	°	Grado sessagesimale - <i>Sexagesimal degree</i> - <i>Angle</i>
Mod.	-	Modello - <i>Model</i> - <i>Modèle</i>
Mat.	-	Materiale - <i>Material</i> - <i>Matière</i>
Dim.	-	Dimensioni - <i>Dimensions</i> - <i>Dimensions</i>
Art.	-	Articolo - <i>Item</i> - <i>Article</i>
Conf.	-	Confezione - <i>Packaging</i> - <i>Conditionnement</i>
Mec	-	Meccanica - <i>Mechanic</i> - <i>Mécanique</i>
Pneu	-	Pneumatica - <i>pneumatic</i> - <i>Pneumatique</i>
Electro	-	Elettronica - <i>Electronic</i> - <i>Électronique</i>

Tutte le quote riportate nel presente listino sono espresse in mm se non diversamente espresso.

*All the dimensions in this price list are in mm except as otherwise expressed.*

*Toutes les dimensions reportées dans le tarif sont exprimées en mm si aucune autre précision.*

Le consegne dei prodotti Valsir vengono effettuate a confezione.

Eventuali richieste non corrispondenti saranno arrotondate, senza preavviso, alla confezione o multipla di essa.

Valsir S.p.A. si riserva il diritto di modificare in qualsiasi momento, le caratteristiche dei prodotti illustrati nel presente listino. I colori riprodotti nel presente listino sono indicativi.

Per conoscere le condizioni di vendita, i termini di garanzia ed esprimere il vostro giudizio di gradimento su Valsir, vi preghiamo di fare riferimento alla Carta dei servizi (fascicolo L02-416) o alla sezione "SUPPORTO" del sito web [www.valsir.it](http://www.valsir.it).

Si invitano tutti gli utilizzatori a segnalare eventuali osservazioni.

*Valsir products are delivered according to the package quantity specified in this price list.*

*Product requests not matching our package quantities will be rounded up, to the package quantity or a multiple of the same. Valsir S.p.A. reserves the right to modify the characteristics of the products shown in this price list at any time. The colours in this price list are shown for representation purposes only.*

*To learn more about our sales conditions, warranty terms and to send us your opinion of Valsir, please refer to our services Card (booklet L02-416) or the "SUPPORT" section of our web site [www.valsir.it](http://www.valsir.it).*

*Please feel free to notify us your comments.*

*Les livraisons des produits Valsir sont effectuées au conditionnement complet. Toutes commandes ne correspondant pas au conditionnement seront arrondies sans préavis au conditionnement supérieur.*

*Valsir S.p.A. se réserve le droit de modifier à tout moment les caractéristiques des produits présentés sur ce tarif.*

*Les couleurs reproduites dans ce tarif sont à titre indicatif.*

*Pour connaître les conditions de vente, les termes de garantie et exprimer son niveau de satisfaction sur Valsir, nous vous prions de vous reporter au Document des services (fascicule L02-433) et à la section "SUPPORT" du site web : [www.valsir.fr](http://www.valsir.fr).*

*Nous invitons tous les utilisateurs à nous faire part de leurs éventuelles observations.*



## TROPEA S: LA PIÙ PERFORMANTE DI SEMPRE

*TROPEA S: THE MOST HIGH-PERFORMANCE FLUSH CISTERN EVER*

*TROPEA S : LA PLUS PERFORMANTE DEPUIS TOUJOURS*

### CARATTERISTICHE

- Connessione idrica girevole, per facilitare e velocizzare l'installazione.
- Connessione ispezionabile al 100%.
- Componenti interni realizzati con materiali che ritardano l'aggressione del calcare.
- Componenti ottimizzati per una manutenzione ancora più agevole.
- Componenti interni unificata con Winner S, Cubik S, Tropea3 e Corallo3 per una gestione ottimale dei ricambi.
- Versatilità negli azionamenti con possibilità d'azionamento meccanico, pneumatico o elettronico.
- Spessore di 84 mm.
- L'assieme del rubinetto d'arresto e del rubinetto galleggiante è certificato in classe I di rumore secondo ISO EN 3822.

### CHARACTERISTICS

- *Rotating water connection fitting for a fast and simple installation.*
- *Connection 100% accessible.*
- *Internal components made of materials that delay the attack of limestone.*
- *Optimized components for an assisted maintenance even further.*
- *Internal components unified for Winner S, Cubik S, Tropea3 and Corallo3 for an improved management of spare parts.*
- *Extreme Versatility: suitable for mechanical, electronic and pneumatic activation systems.*
- *Thickness 84 mm.*
- *The combination of the stop valve and the floating valve is certified in noise class I according to ISO EN 3822.*

### CARACTÉRISTIQUES

- *Connexion hydrique rotative pour faciliter et accélérer l'installation.*
- *Connexion inspectable à 100%.* Composants internes réalisés avec des matériaux qui retardent l'agression du calcaire.
- *Composants optimisés pour un entretien encore plus facile.* Composants internes standardisés avec Winner S, Cubik S, Tropea3 et Corallo3 pour une gestion optimale des pièces de rechange.
- *Polyvalence dans les actionnements avec possibilité d'actionnement mécanique, pneumatique ou électronique.*
- *Épaisseur de 84 mm.*
- *L'ensemble du robinet d'arrêt et du robinet à flotteur est certifié en classe I de bruit selon l'ISO EN 3822.*





## MURARE IN-WALL - À ENCASTRER

# S84

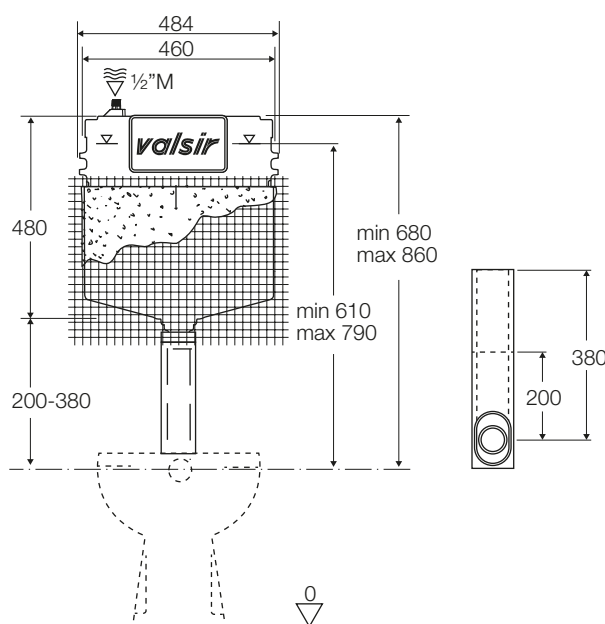



- **Tipologia WC:** a terra
- **Tipologia installazione:** mattoni, a secco, legno
- **Volume scarico:** 6/3 (pre-regolato), 4,5/3, 4/2 l
- **Posizione placca:** frontale
- **Materiale fissaggio:** incluso
- **Kit tubi pneumatico remoto:** non incluso

- **WC type:** floor standing pans
- **Installation:** masonry walls, dry walls, stud frame walls
- **Flush volume:** 6/3 (standard setting), 4.5/3, 4/2 l
- **Plate position:** front
- **Fixing material:** included
- **Pneumatic hoses kit for remote installation:** not included

- **Typologie WC :** au sol
- **Typologie installation :** briques, à sec, bois
- **Volume chasse d'eau :** 6/3 (pré-réglé), 4,5/3, 4/2 l
- **Emplacement command :** frontal
- **Matériel de fixation :** inclus
- **Kit tuyaux pneumatique à distance :** non inclus

COD.	Mod.	Rivestimento Covering - Revêtement	SxLxH	
VS0858002	mec	rete e foderina - net and lining - crépine et fourreau	84x484x480	5
VS0858052	pneu	rete e foderina - net and lining - crépine et fourreau	84x484x480	5
VS0858021	electro	rete e foderina - net and lining - crépine et fourreau	84x484x480	5

	Pz - Pcs	HxLxP	kg	m <sup>3</sup>
	1	568x671x111	4	0,042

	Pz - Pcs	HxLxP	kg	m <sup>3</sup>
	5	570x681x593	20,2	0,23

	Pz - Pcs	HxLxP	kg	m <sup>3</sup>
	60	1950x1200x1400	255	3,27

## MURARE IN-WALL - À ENCASTRER

# S84

## ARIAPUR

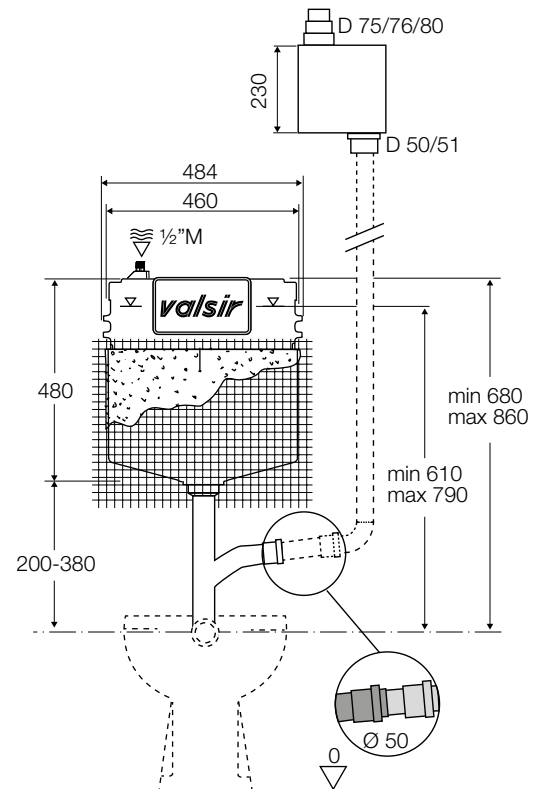



- **Tipologia WC:** a terra
- **Tipologia installazione:** mattoni, a secco, legno
- **Sistema Ariapur:** incluso
- **Volume scarico:** 6/3 (pre-regolato), 4,5/3, 4/2 l
- **Posizione placca:** frontale
- **Materiale fissaggio:** incluso
- **Kit tubi pneumatico remoto:** non incluso

- **WC type:** floor standing pans
- **Installation:** masonry walls, dry walls, stud frame walls
- **Ariapur system:** included
- **Flush volume:** 6/3 (standard setting), 4.5/3, 4/2 l
- **Plate position:** front
- **Fixing material:** included
- **Pneumatic hoses kit for remote installation:** not included

- **Typologie WC :** au sol
- **Typologie installation :** briques, à sec, bois
- **Système Ariapur :** inclus
- **Volume chasse d'eau :** 6/3 (pré-réglé), 4,5/3, 4/2 l
- **Emplacement command :** frontal
- **Matériel de fixation :** inclus
- **Kit tuyaux pneumatique à distance :** non inclus

COD.	Mod.	Rivestimento Covering - Revêtement	SxLxH	
VS0858302	mec	rete e foderina - net and lining - crépine et fourreau	84x484x480	1
VS0858352	pneu	rete e foderina - net and lining - crépine et fourreau	84x484x480	1

 Pz - Pcs	HxLxP	kg	m <sup>3</sup>
1	480x660x290	7,1	0,092

 Pz - Pcs	HxLxP	kg	m <sup>3</sup>
16	2120x1200x800	123	2,03

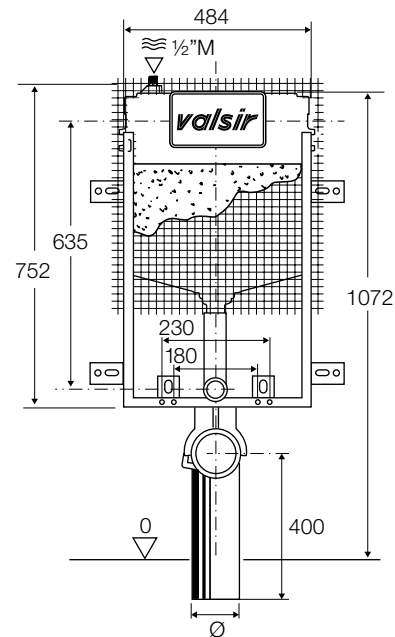
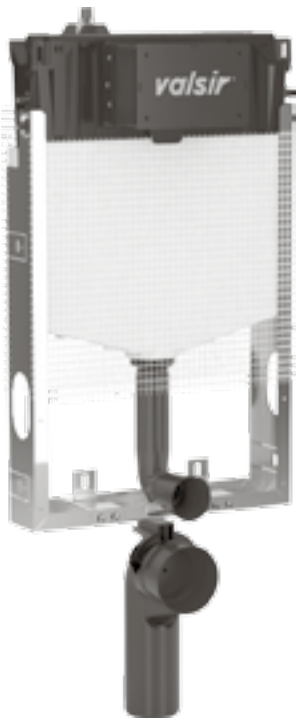

- **Tipologia WC:** sospeso
- **Tipologia installazione:** mattoni
- **Volume scarico:** 6/3 (pre-regolato), 4,5/3, 4/2 l
- **Posizione placca:** frontale
- **Materiale fissaggio:** incluso
- **Kit tubi pneumatico remoto:** non incluso

- **WC type:** wall-hung pans
- **Installation:** masonry walls
- **Flush volume:** 6/3 (standard setting), 4.5/3, 4/2 l
- **Plate position:** front
- **Fixing material:** included
- **Pneumatic hoses kit for remote installation:** not included

- **Typologie WC :** suspendu
- **Typologie installation :** briques
- **Volume chasse d'eau :** 6/3 (pré-réglé), 4,5/3, 4/2 l
- **Emplacement command :** frontal
- **Matériel de fixation :** inclus
- **Kit tuyaux pneumatique à distance :** non inclus

COD.	Mod.	Rivestimento Covering - Revêtement	SxLxH	Curva Bend - Coude	
VS0858102	mec	rete e foderina - net and lining - crépine et fourreau	86x484x1072	Ø 90 - L 400	1
VS0858152	pneu	rete e foderina - net and lining - crépine et fourreau	86x484x1072	Ø 90 - L 400	1
VS0858121	electro	rete e foderina - net and lining - crépine et fourreau	86x484x1072	Ø 90 - L 400	1

Raccordi di passaggio per lo scarico a pagina 91. - Fittings for connection to waste at page 91. - Raccords de passage pour l'évacuation page 91.

	Pz - Pcs	HxLxP	kg	m <sup>3</sup>
	1	830x610x145	7,3	0,073

	Pz - Pcs	HxLxP	kg	m <sup>3</sup>
	16	1350x1200x860	125	1,62

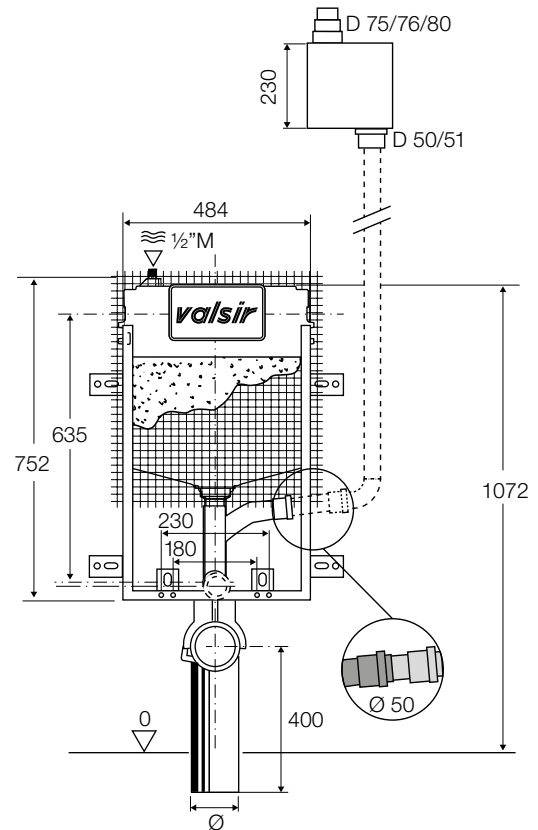

- **Tipologia WC:** sospeso
- **Tipologia installazione:** mattoni
- **Sistema Ariapur:** incluso
- **Volume scarico:** 6/3 (pre-regolato), 4,5/3, 4/2 l
- **Posizione placca:** frontale
- **Materiale fissaggio:** incluso
- **Kit tubi pneumatico remoto:** non incluso

- **WC type:** wall-hung pans
- **Installation:** masonry walls
- **Ariapur system:** included
- **Flush volume:** 6/3 (standard setting), 4.5/3, 4/2 l
- **Plate position:** front
- **Fixing material:** included
- **Pneumatic hoses kit for remote installation:** not included

- **Typologie WC :** suspendu
- **Typologie installation :** briques
- **Système Ariapur :** inclus
- **Volume chasse d'eau :** 6/3 (pré-réglé), 4,5/3, 4/2 l
- **Emplacement command :** frontal
- **Matériel de fixation :** inclus
- **Kit tuyaux pneumatique à distance :** non inclus

COD.	Mod.	Rivestimento Covering - Revêtement	SxLxH	Curva Bend - Coude	
VS0858303	mec	rete e foderina - net and lining - crépine et fourreau	86x484x1072	Ø 90 - L 400	1
VS0858353	pneu	rete e foderina - net and lining - crépine et fourreau	86x484x1072	Ø 90 - L 400	1

Raccordi di passaggio per lo scarico a pagina 91. - Fittings for connection to waste at page 91. - Raccords de passage pour l'évacuation page 91.

	Pz - Pcs	HxLxP	kg	m <sup>3</sup>
1	1	910x780x175	11	0,124

	Pz - Pcs	HxLxP	kg	m <sup>3</sup>
14	14	1680x1200x800	163	1,61

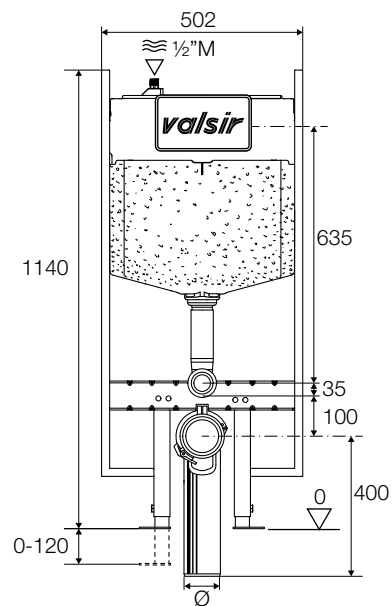

- **Tipologia WC:** sospeso
- **Tipologia installazione:** a secco, legno
- **Volume scarico:** 6/3 (pre-regolato), 4,5/3, 4/2 l
- **Posizione placca:** frontale
- **Materiale fissaggio:** incluso
- **Kit tubi pneumatico remoto:** non incluso

- **WC type:** wall-hung pans
- **Installation:** dry walls, stud frame walls
- **Flush volume:** 6/3 (standard setting), 4,5/3, 4/2 l
- **Plate position:** front
- **Fixing material:** included
- **Pneumatic hoses kit for remote installation:** not included

- **Typologie WC :** suspendu
- **Typologie installation :** à sec, bois
- **Volume chasse d'eau :** 6/3 (pré-réglé), 4,5/3, 4/2 l
- **Emplacement command :** frontal
- **Matériel de fixation :** inclus
- **Kit tuyaux pneumatique à distance :** non inclus

COD.	Mod.	Rivestimento Covering - Revêtement	SxLxH	Curva Bend - Coude	
VS0858211	mec	foderina - lining - gaine	90x502x1140	Ø 90 - L 400	1
VS0858255	pneu	foderina - lining - gaine	90x502x1140	Ø 90 - L 400	1
VS0858221	electro	foderina - lining - gaine	90x502x1140	Ø 90 - L 400	1

Raccordi di passaggio per lo scarico a pagina 91. - Fittings for connection to waste at page 91. - Raccords de passage pour l'évacuation page 91.

 Pz - Pcs	HxLxP	kg	m <sup>3</sup>
1	1150x520x150	13,4	0,090

 Pz - Pcs	HxLxP	kg	m <sup>3</sup>
11	1270x1200x850	155	1,30

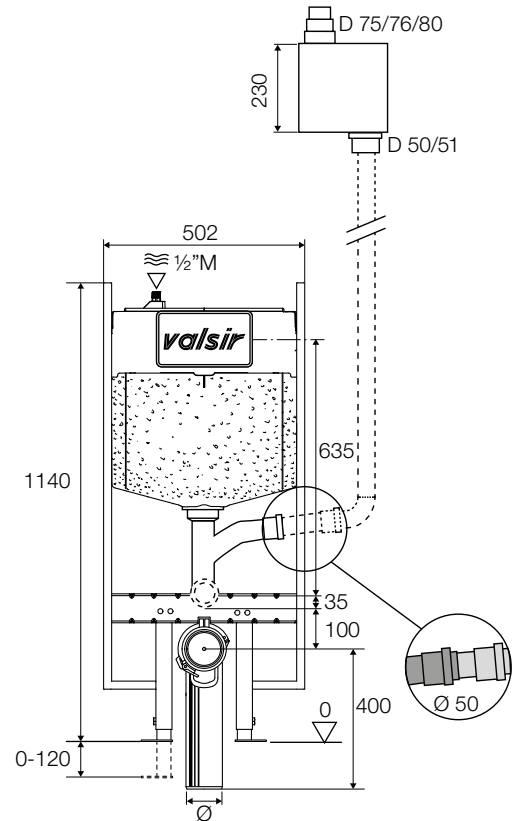

- **Tipologia WC:** sospeso
- **Tipologia installazione:** a secco, legno
- **Sistema Ariapur:** incluso
- **Volume scarico:** 6/3 (pre-regolato), 4,5/3, 4/2 l
- **Posizione placca:** frontale
- **Materiale fissaggio:** incluso
- **Kit tubi pneumatico remoto:** non incluso

- **WC type:** wall-hung pans
- **Installation:** dry walls, stud frame walls
- **Ariapur system:** included
- **Flush volume:** 6/3 (standard setting), 4.5/3, 4/2 l
- **Plate position:** front
- **Fixing material:** included
- **Pneumatic hoses kit for remote installation:** not included

- **Typologie WC :** suspendu
- **Typologie installation :** à sec, bois
- **Système Ariapur :** inclus
- **Volume chasse d'eau :** 6/3 (pré-réglé), 4,5/3, 4/2 l
- **Emplacement command :** frontal
- **Matériel de fixation :** inclus
- **Kit tuyaux pneumatique à distance :** non inclus

COD.	Mod.	Rivestimento Covering - Revêtement	SxLxH	Curva Bend - Coude	
VS0858311	mec	foderina - lining - gaine	90x502x1140	Ø 90 - L 400	1
VS0858355	pneu	foderina - lining - gaine	90x502x1140	Ø 90 - L 400	1

Raccordi di passaggio per lo scarico a pagina 91. - Fittings for connection to waste at page 91. - Raccords de passage pour l'évacuation page 91.

	Pz - Pcs	HxLxP	kg	m <sup>3</sup>
1	1	1190x800x170	16,4	0,162

	Pz - Pcs	HxLxP	kg	m <sup>3</sup>
6	6	1280x1200x800	107	1,2



# BLOCK AUTOPORTANTE

## FREE-STANDING BLOCK - BLOCK AUTOPORTANT

# S160

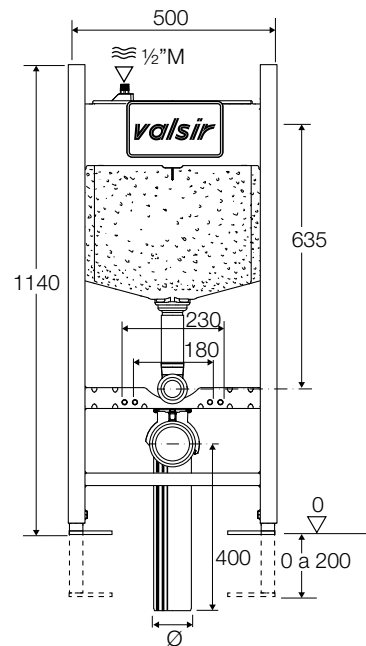

- **Tipologia WC:** sospeso
- **Tipologia installazione:** a pavimento
- **Volume scarico:** 6/3 (pre-regolato), 4,5/3, 4/2 l
- **Posizione placca:** frontale
- **Materiale fissaggio:** incluso
- **Kit tubi pneumatico remoto:** non incluso

- **WC type:** wall-hung pans
- **Installation:** anchored to the floor in dry walls
- **Flush volume:** 6/3 (standard setting), 4.5/3, 4/2 l
- **Plate position:** front
- **Fixing material:** included
- **Pneumatic hoses kit for remote installation:** not included

- **Typologie WC :** suspendu
- **Typologie installation :** au plancher
- **Volume chasse d'eau :** 6/3 (pré-réglé), 4,5/3, 4/2 l
- **Emplacement command :** frontal
- **Matériel de fixation :** inclus
- **Kit tuyaux pneumatique à distance :** non inclus

COD.	Mod.	Rivestimento Covering - Revêtement	SxLxH	Curva Bend - Coude	
VS0858401	mec	foderina - lining - gaine	160x500x1140	Ø 90 - L 400	1
VS0858451	pneu	foderina - lining - gaine	160x500x1140	Ø 90 - L 400	1

Raccordi di passaggio per lo scarico a pagina 91. - Fittings for connection to waste at page 91. - Raccords de passage pour l'évacuation page 91.

 Pz - Pcs	HxLxP	kg	m <sup>3</sup>
1	1170x520x155	16,2	0,094

 Pz - Pcs	HxLxP	kg	m <sup>3</sup>
11	1270x1200x850	187	1,3



## WINNER S: LA RIVOLUZIONE NEI SISTEMI DI RISCIAQUO

### WINNER S: THE REVOLUTION IN FLUSHING SYSTEMS

### WINNER S : UN SYSTÈME DE RINÇAGE RÉVOLUTIONNAIRE

#### CARATTERISTICHE

- Il materiale del contenitore assicura un elevato assorbimento delle vibrazioni acustiche.
- Possibilità di installazione a 3 diverse altezze: 800, 880 e 1140 mm.
- I materiali dei componenti interni ostacolano la formazione del calcare.
- Il raccordo d'alimentazione girevole facilita e velocizza l'installazione.
- Componenti interni unificati con Tropea S e Cubik S.
- I componenti interni sono certificati secondo la ISO EN 3822 in classe I di silenziosità a 3 e 5 bar.
- La regolazione dello scarico è a 6/3, 4,5/3 e 4/2 litri nel rispetto della salvaguardia delle risorse e dei principi del green building.

#### CHARACTERISTICS

- *The material used for the tank ensure a high vibration absorption.*
- *Flexibility of installation; it can be installed at 3 different heights: 800, 880 and 1140 mm.*
- *Internal component materials prevent the conformation of limescale.*
- *Swiveling connection fitting makes installation easier and quicker.*
- *Same internal components as Tropea S and Cubik S.*
- *Internal components compliant with the ISO EN 3822 noise level class I certification at 3 and 5 bar.*
- *According to the Green Building philosophy flush volume of 6/3, 4.5/3 and 4/2 liters in order to reduce water consumption.*

#### CARACTÉRISTIQUES

- *Le matériel du boîtier assure une absorption élevée des vibrations sonores.*
- *Possibilité d'installation selon 3 hauteurs différentes : 800, 880 et 1140 mm.*
- *Les matériaux des composants internes empêchent la formation du calcaire.*
- *Le raccord d'alimentation pivotant facilite et accélère l'installation.*
- *Composants internes standardisés avec Tropea S et Cubik S.*
- *Les composants internes sont certifiés selon la norme ISO EN 3822 avec classe I de niveau de bruit à 3 et 5 bars.*
- *Le réglage de chasse d'eau est à 6/3, 4,5/3 et 4/2 litres conformément aux normes de sauvegarde des ressources et des principes d'une approche écologique de la construction.*



# MURARE - H 800

IN-WALL - À ENCASTRER

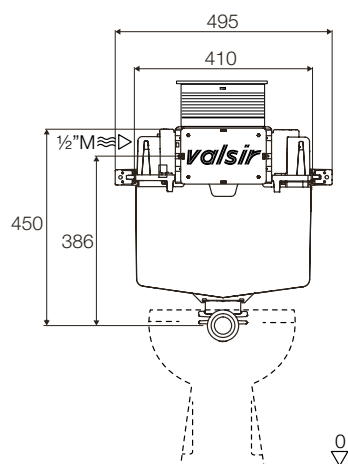

# S120





- **Tipologia WC:** a terra
- **Tipologia installazione:** mattoni, a secco, legno
- **Volume scarico:** 6/3 (pre-regolato), 4,5/3, 4/2 l
- **Posizione placca:** frontale o superiore
- **Materiale fissaggio:** incluso
- **Kit tubi pneumatico remoto:** non incluso

- **WC type:** floor standing pans
- **Installation:** masonry walls, dry walls, stud frame walls
- **Flush volume:** 6/3 (standard setting), 4.5/3, 4/2 l
- **Plate position:** front or top
- **Fixing material:** included
- **Pneumatic hoses kit for remote installation:** not included

- **Typologie WC :** au sol
- **Typologie installation :** briques, à sec, bois
- **Volume chasse d'eau :** 6/3 (pré-réglé), 4,5/3, 4/2 l
- **Emplacement command :** frontal or supérieur
- **Matériel de fixation :** inclus
- **Kit tuyaux pneumatique à distance :** non inclus

COD.	Mod.	Rivestimento Covering - Revêtement	SxLxH	
 VS0853008	mec	foderina - lining - gaine	120x495x800	5
 VS0853058	pneu	foderina - lining - gaine	120x495x800	5

 Pz - Pcs	HxLxP	kg	m <sup>3</sup>
1	460x625x140	3,37	0,04

 Pz - Pcs	HxLxP	kg	m <sup>3</sup>
5	480x730x640	16,8	0,22

 Pz - Pcs	HxLxP	kg	m <sup>3</sup>
60	2275x1200x1400	210	3,82

# MURARE - H 880

IN-WALL - À ENCASTRER

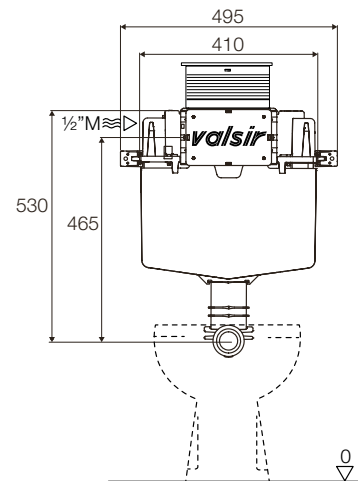

# S120





- **Tipologia WC:** a terra
- **Tipologia installazione:** mattoni, a secco, legno
- **Volume scarico:** 6/3 (pre-regolato), 4,5/3, 4/2 l
- **Posizione placca:** frontale o superiore
- **Materiale fissaggio:** incluso
- **Kit tubi pneumatico remoto:** non incluso

- **WC type:** floor standing pans
- **Installation:** masonry walls, dry walls, stud frame walls
- **Flush volume:** 6/3 (standard setting), 4.5/3, 4/2 l
- **Plate position:** front or top
- **Fixing material:** included
- **Pneumatic hoses kit for remote installation:** not included

- **Typologie WC :** au sol
- **Typologie installation :** briques, à sec, bois
- **Volume chasse d'eau :** 6/3 (pré-réglé), 4,5/3, 4/2 l
- **Emplacement command :** frontal or supérieur
- **Matériel de fixation :** inclus
- **Kit tuyaux pneumatique à distance :** non inclus

COD.	Mod.	Rivestimento Covering - Revêtement	SxLxH	
 VS0853004	mec	foderina - lining - gaine	120x495x880	5
 VS0853054	pneu	foderina - lining - gaine	120x495x880	5

 Pz - Pcs	HxLxP	kg	m <sup>3</sup>
1	460x625x140	3,37	0,04

 Pz - Pcs	HxLxP	kg	m <sup>3</sup>
5	480x730x640	16,8	0,22

 Pz - Pcs	HxLxP	kg	m <sup>3</sup>
60	2275x1200x1400	210	3,82

# MURARE - H 1140

IN-WALL - À ENCASTRER



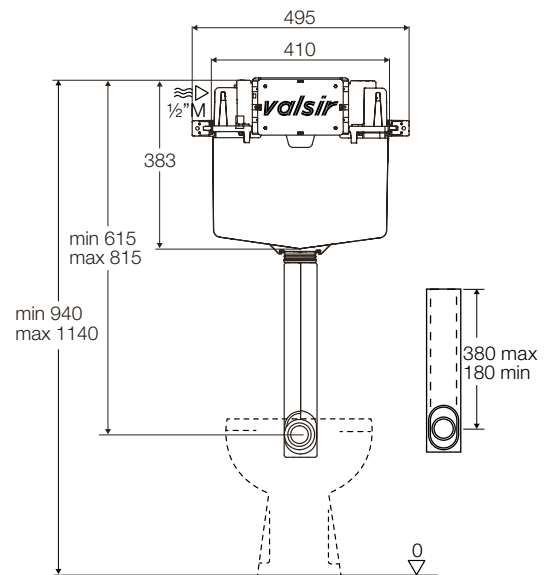

# S120





- **Tipologia WC:** a terra
- **Tipologia installazione:** mattoni, a secco, legno
- **Volume scarico:** 6/3 (pre-regolato), 4,5/3, 4/2 l
- **Posizione placca:** frontale
- **Materiale fissaggio:** incluso
- **Kit tubi pneumatico remoto:** non incluso

- **WC type:** floor standing pans
- **Installation:** masonry walls, dry walls, stud frame walls
- **Flush volume:** 6/3 (standard setting), 4.5/3, 4/2 l
- **Plate position:** front
- **Fixing material:** included
- **Pneumatic hoses kit for remote installation:** not included

- **Typologie WC :** au sol
- **Typologie installation :** briques, à sec, bois
- **Volume chasse d'eau :** 6/3 (pré-réglé), 4,5/3, 4/2 l
- **Emplacement command :** frontal
- **Matériel de fixation :** inclus
- **Kit tuyaux pneumatique à distance :** non inclus

COD.	Mod.	Rivestimento Covering - Revêtement	SxLxH	
 VS0853002	mec	foderina - lining - gaine	120x495x383	5
 VS0853052	pneu	foderina - lining - gaine	120x495x383	5
 VS0853022	electro	foderina - lining - gaine	120x495x383	5

	Pz - Pcs	HxLxP	kg	m <sup>3</sup>
	1	460x625x140	3,37	0,04

	Pz - Pcs	HxLxP	kg	m <sup>3</sup>
	5	480x730x640	16,8	0,22

	Pz - Pcs	HxLxP	kg	m <sup>3</sup>
	60	2275x1200x1400	210	3,82

# MURARE - H 1140

IN-WALL - À ENCASTRER

# S120

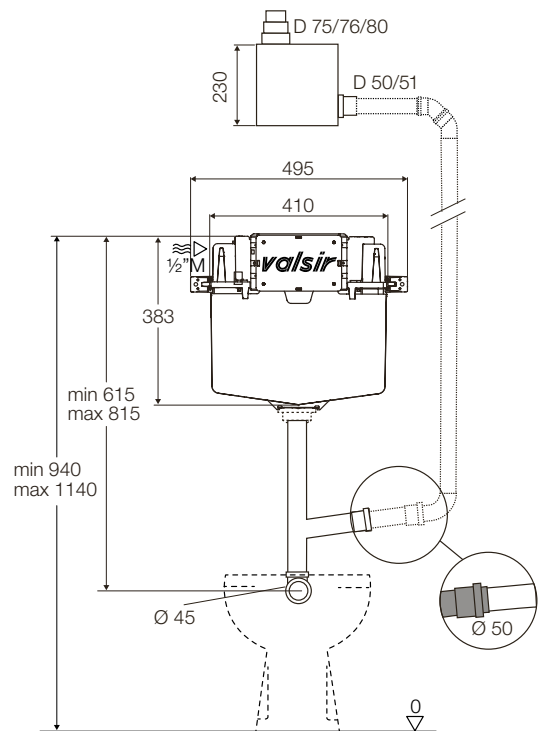

**ARIAPUR**



- **Tipologia WC:** a terra
- **Tipologia installazione:** mattoni, a secco, legno
- **Sistema Ariapur:** incluso
- **Volume scarico:** 6/3 (pre-regolato), 4,5/3, 4/2 l
- **Posizione placca:** frontale
- **Materiale fissaggio:** incluso
- **Kit tubi pneumatico remoto:** non incluso

- **WC type:** floor standing pans
- **Installation:** masonry walls, dry walls, stud frame walls
- **Ariapur system:** included
- **Flush volume:** 6/3 (standard setting), 4.5/3, 4/2 l
- **Plate position:** front
- **Fixing material:** included
- **Pneumatic hoses kit for remote installation:** not included

- **Typologie WC :** au sol
- **Typologie installation :** briques, à sec, bois
- **Système Ariapur :** inclus
- **Volume chasse d'eau :** 6/3 (pré-réglé), 4,5/3, 4/2 l
- **Emplacement command :** frontal
- **Matériel de fixation :** inclus
- **Kit tuyaux pneumatique à distance :** non inclus

COD.	Mod.	Rivestimento Covering - Revêtement	SxLxH	
 VS0853302	mec	foderina - lining - gaine	120x495x383	1
 VS0853352	pneu	foderina - lining - gaine	120x495x383	1

 Pz - Pcs	HxLxP	kg	m <sup>3</sup>
1	485x655x285	6,8	0,09

 Pz - Pcs	HxLxP	kg	m <sup>3</sup>
16	2100x800x1200	117	2,02



# FIXSYSTEM - H 800

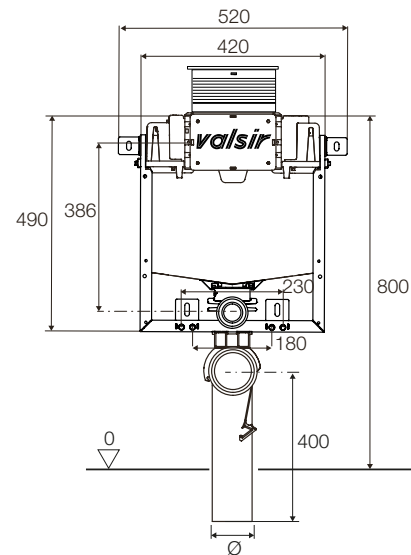

# S120



- **Tipologia WC:** sospeso
- **Tipologia installazione:** mattoni
- **Volume scarico:** 6/3 (pre-regolato), 4,5/3, 4/2 l
- **Posizione placca:** frontale o superiore
- **Materiale fissaggio:** incluso
- **Kit tubi pneumatico remoto:** non incluso

- **WC type:** wall-hung pans
- **Installation:** masonry walls
- **Flush volume:** 6/3 (standard setting), 4.5/3, 4/2 l
- **Plate position:** front or top
- **Fixing material:** included
- **Pneumatic hoses kit for remote installation:** not included

- **Typologie WC :** suspendu
- **Typologie installation :** briques
- **Volume chasse d'eau :** 6/3 (pré-réglé), 4,5/3, 4/2 l
- **Emplacement command :** frontal or supérieur
- **Matériel de fixation :** inclus
- **Kit tuyaux pneumatique à distance :** non inclus

COD.	Mod.	Rivestimento Covering - Revêtement	SxLxH	Curva Bend - Coude	
 VS0853145	mec	foderina - lining - gaine	120x520x800	Ø 90 - L 400	1
 VS0853175	pneu	foderina - lining - gaine	120x520x800	Ø 90 - L 400	1

Raccordi di passaggio per lo scarico a pagina 91. - Fittings for connection to waste at page 91. - Raccords de passage pour l'évacuation page 91.

 Pz - Pcs	HxLxP	kg	m <sup>3</sup>
1	450x885x140	7,6	0,05

 Pz - Pcs	HxLxP	kg	m <sup>3</sup>
24	1600x800x1200	190	1,54

# FIXSYSTEM - H 880

# S120

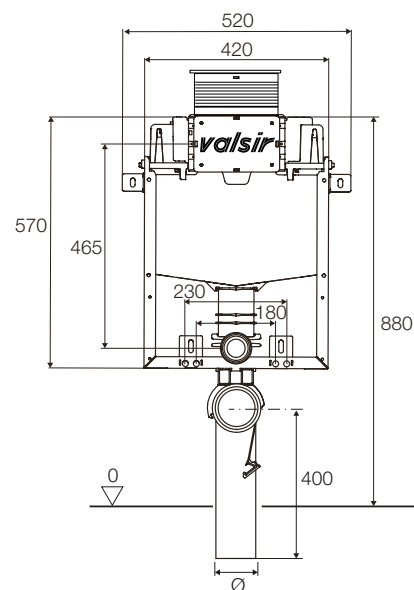

- **Tipologia WC:** sospeso
- **Tipologia installazione:** mattoni
- **Volume scarico:** 6/3 (pre-regolato), 4,5/3, 4/2 l
- **Posizione placca:** frontale o superiore
- **Materiale fissaggio:** incluso
- **Kit tubi pneumatico remoto:** non incluso

- **WC type:** wall-hung pans
- **Installation:** masonry walls
- **Flush volume:** 6/3 (standard setting), 4.5/3, 4/2 l
- **Plate position:** front or top
- **Fixing material:** included
- **Pneumatic hoses kit for remote installation:** not included

- **Typologie WC :** suspendu
- **Typologie installation :** briques
- **Volume chasse d'eau :** 6/3 (pré-réglé), 4,5/3, 4/2 l
- **Emplacement command :** frontal or supérieur
- **Matériel de fixation :** inclus
- **Kit tuyaux pneumatique à distance :** non inclus

COD.	Mod.	Rivestimento Covering - Revêtement	SxLxH	Curva Bend - Coude	
 VS0853111	mec	foderina - lining - gaine	120x520x880	Ø 90 - L 400	1
 VS0853161	pneu	foderina - lining - gaine	120x520x880	Ø 90 - L 400	1

Raccordi di passaggio per lo scarico a pagina 91. - Fittings for connection to waste at page 91. - Raccords de passage pour l'évacuation page 91.

 Pz - Pcs	HxLxP	kg	m <sup>3</sup>
1	450x885x140	7,6	0,05

 Pz - Pcs	HxLxP	kg	m <sup>3</sup>
24	1600x800x1200	190	1,54

# FIXSYSTEM - H 1050



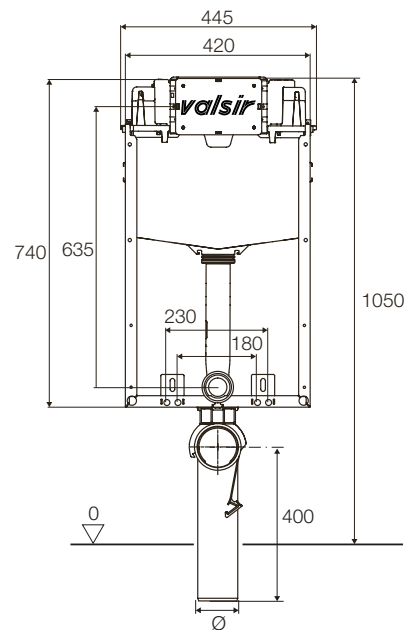
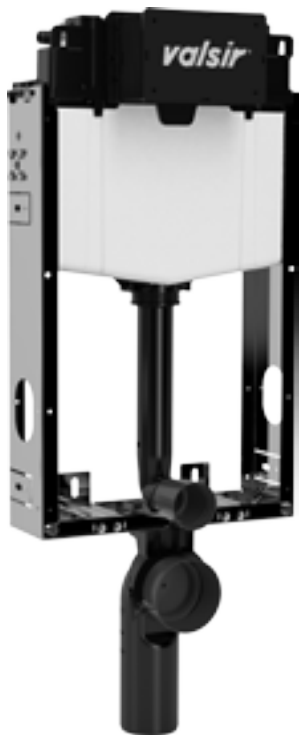

# S120



- **Tipologia WC:** sospeso
- **Tipologia installazione:** mattoni
- **Volume scarico:** 6/3 (pre-regolato), 4,5/3, 4/2 l
- **Posizione placca:** frontale o superiore
- **Materiale fissaggio:** incluso
- **Kit tubi pneumatico remoto:** non incluso

- **WC type:** wall-hung pans
- **Installation:** masonry walls
- **Flush volume:** 6/3 (standard setting), 4.5/3, 4/2 l
- **Plate position:** front or top
- **Fixing material:** included
- **Pneumatic hoses kit for remote installation:** not included

- **Typologie WC :** suspendu
- **Typologie installation :** briques
- **Volume chasse d'eau :** 6/3 (pré-réglé), 4,5/3, 4/2 l
- **Emplacement command :** frontal
- **Matériel de fixation :** inclus
- **Kit tuyaux pneumatique à distance :** non inclus

COD.	Mod.	Rivestimento Covering - Revêtement	SxLxH	Curva Bend - Coude	
 VS0853101	mec	foderina - lining - gaine	120x445x1050	Ø 90 - L 400	1
 VS0853151	pneu	foderina - lining - gaine	120x445x1050	Ø 90 - L 400	1
 VS0853121	electro	foderina - lining - gaine	120x445x1050	Ø 90 - L 400	1

Raccordi di passaggio per lo scarico a pagina 91. - Fittings for connection to waste at page 91. - Raccords de passage pour l'évacuation page 91.

 Pz - Pcs	HxLxP	kg	m <sup>3</sup>
1	465x853x140	7,6	0,05

 Pz - Pcs	HxLxP	kg	m <sup>3</sup>
24	1900x800x1200	190	1,82

# FIXSYSTEM - H 1050

# S120

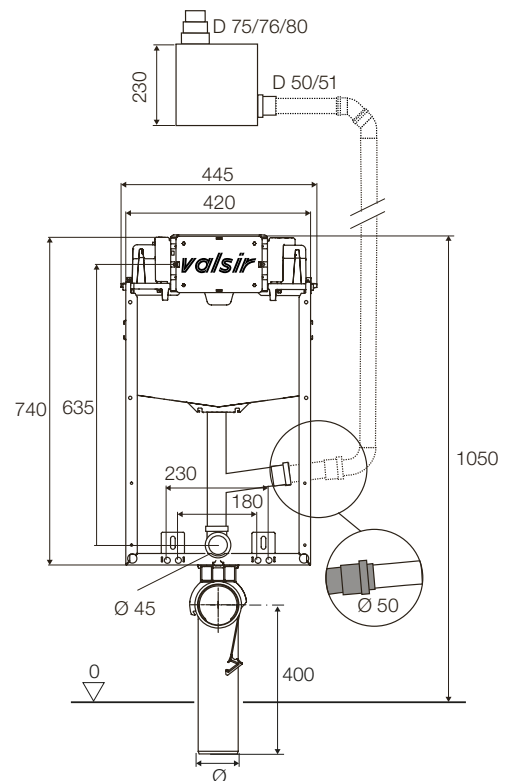
**ARIAPUR**



- **Tipologia WC:** sospeso
- **Tipologia installazione:** mattoni
- **Sistema Ariapur:** incluso
- **Volume scarico:** 6/3 (pre-regolato), 4,5/3, 4/2 l
- **Posizione placca:** frontale
- **Materiale fissaggio:** incluso
- **Kit tubi pneumatico remoto:** non incluso

- **WC type:** wall-hung pans
- **Installation:** masonry walls
- **Ariapur system:** included
- **Flush volume:** 6/3 (standard setting), 4.5/3, 4/2 l
- **Plate position:** front
- **Fixing material:** included
- **Pneumatic hoses kit for remote installation:** not included

- **Typologie WC :** suspendu
- **Typologie installation :** briques
- **Système Ariapur :** inclus
- **Volume chasse d'eau :** 6/3 (pré-réglé), 4,5/3, 4/2 l
- **Emplacement commande :** frontal
- **Matériel de fixation :** inclus
- **Kit tuyaux pneumatique à distance :** non inclus

COD.	Mod.	Rivestimento Covering - Revêtement	SxLxH	Curva Bend - Coude	
 VS0853311	mec	foderina - lining - gaine	120x445x1050	Ø 90 - L 400	1
 VS0853361	pneu	foderina - lining - gaine	120x445x1050	Ø 90 - L 400	1

Raccordi di passaggio per lo scarico a pagina 91. - Fittings for connection to waste at page 91. - Raccords de passage pour l'évacuation page 91.

 Pz - Pcs	HxLxP	kg	m <sup>3</sup>
1	780x770x175	10,6	0,10

 Pz - Pcs	HxLxP	kg	m <sup>3</sup>
14	2310x800x1200	156	2,22

# BLOCK - H 800

# S160

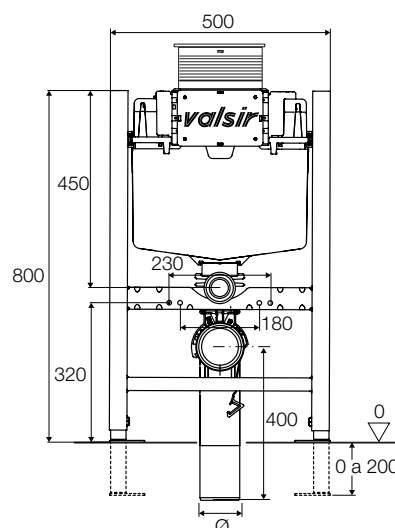

- **Tipologia WC:** sospeso
- **Tipologia installazione:** a secco, legno
- **Volume scarico:** 6/3 (pre-regolato), 4,5/3, 4/2 l
- **Posizione placca:** frontale o superiore
- **Materiale fissaggio:** incluso
- **Kit tubi pneumatico remoto:** non incluso

- **WC type:** wall-hung pans
- **Installation:** dry walls, stud frame walls
- **Flush volume:** 6/3 (standard setting), 4.5/3, 4/2 l
- **Plate position:** front or top
- **Fixing material:** included
- **Pneumatic hoses kit for remote installation:** not included

- **Typologie WC :** suspendu
- **Typologie installation :** à sec, bois
- **Volume chasse d'eau :** 6/3 (pré-réglé), 4,5/3, 4/2 l
- **Emplacement command :** frontal or supérieur
- **Matériel de fixation :** inclus
- **Kit tuyaux pneumatique à distance :** non inclus

COD.	Mod.	Rivestimento Covering - Revêtement	SxLxH	Curva Bend - Coude	
 VS0853245	mec	foderina - lining - gaine	120x500x800	Ø 90 - L 400	1
 VS0853275	pneu	foderina - lining - gaine	120x500x800	Ø 90 - L 400	1

Raccordi di passaggio per lo scarico a pagina 91. - Fittings for connection to waste at page 91. - Raccords de passage pour l'évacuation page 91.

 Pz - Pcs	HxLxP	kg	m <sup>3</sup>
1	895x520x165	12,9	0,08

 Pz - Pcs	HxLxP	kg	m <sup>3</sup>
18	2005x800x1200	240	1,92

# BLOCK - H 880

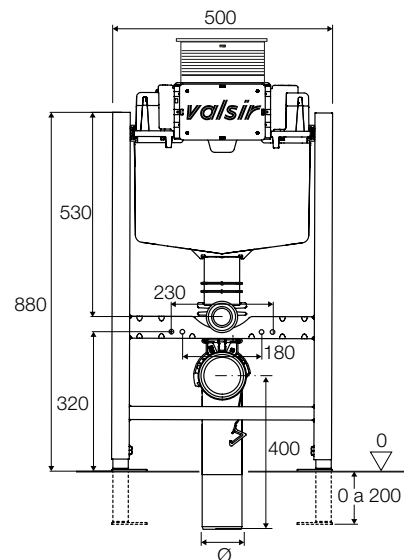

# S160



- **Tipologia WC:** sospeso
- **Tipologia installazione:** a secco, legno
- **Volume scarico:** 6/3 (pre-regolato), 4,5/3, 4/2 l
- **Posizione placca:** frontale o superiore
- **Materiale fissaggio:** incluso
- **Kit tubi pneumatico remoto:** non incluso

- **WC type:** wall-hung pans
- **Installation:** dry walls, stud frame walls
- **Flush volume:** 6/3 (standard setting), 4.5/3, 4/2 l
- **Plate position:** front or top
- **Fixing material:** included
- **Pneumatic hoses kit for remote installation:** not included

- **Typologie WC :** suspendu
- **Typologie installation :** à sec, bois
- **Volume chasse d'eau :** 6/3 (pré-réglé), 4,5/3, 4/2 l
- **Emplacement command :** frontal or supérieur
- **Matériel de fixation :** inclus
- **Kit tuyaux pneumatique à distance :** non inclus

COD.	Mod.	Rivestimento Covering - Revêtement	SxLxH	Curva Bend - Coude	
 VS0853211	mec	foderina - lining - gaine	120x500x880	Ø 90 - L 400	1
 VS0853261	pneu	foderina - lining - gaine	120x500x880	Ø 90 - L 400	1

Raccordi di passaggio per lo scarico a pagina 91. - Fittings for connection to waste at page 91. - Raccords de passage pour l'évacuation page 91.

 Pz - Pcs	HxLxP	kg	m <sup>3</sup>
1	895x520x165	12,9	0,08

 Pz - Pcs	HxLxP	kg	m <sup>3</sup>
18	2005x800x1200	240	1,92



# BLOCK - H 1140



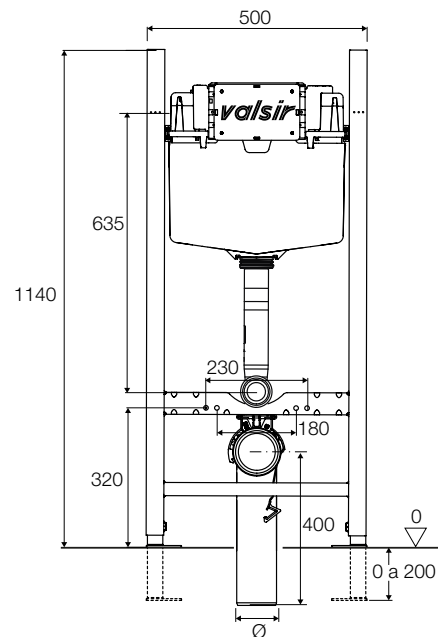

# S160



- **Tipologia WC:** sospeso
- **Tipologia installazione:** a secco, legno
- **Volume scarico:** 6/3 (pre-regolato), 4,5/3, 4/2 l
- **Posizione placca:** frontale
- **Materiale fissaggio:** incluso
- **Kit tubi pneumatico remoto:** non incluso

- **WC type:** wall-hung pans
- **Installation:** dry walls, stud frame walls
- **Flush volume:** 6/3 (standard setting), 4.5/3, 4/2 l
- **Plate position:** front
- **Fixing material:** included
- **Pneumatic hoses kit for remote installation:** not included

- **Typologie WC :** suspendu
- **Typologie installation :** à sec, bois
- **Volume chasse d'eau :** 6/3 (pré-réglé), 4,5/3, 4/2 l
- **Emplacement command :** frontal
- **Matériel de fixation :** inclus
- **Kit tuyaux pneumatique à distance :** non inclus

COD.	Mod.	Rivestimento Covering - Revêtement	SxLxH	Curva Bend - Coude	
 VS0853201	mec	foderina - lining - gaine	120x500x1140	Ø 90 - L 400	1
 VS0853251	pneu	foderina - lining - gaine	120x500x1140	Ø 90 - L 400	1
 VS0853221	electro	foderina - lining - gaine	120x500x1140	Ø 90 - L 400	1

Raccordi di passaggio per lo scarico a pagina 91. - Fittings for connection to waste at page 91. - Raccords de passage pour l'évacuation page 91.

 Pz - Pcs	HxLxP	kg	m³
1	1155x520x150	12,9	0,09

 Pz - Pcs	HxLxP	kg	m³
11	1280x800x1200	150	1,23

## BLOCK - H 1140

# S120

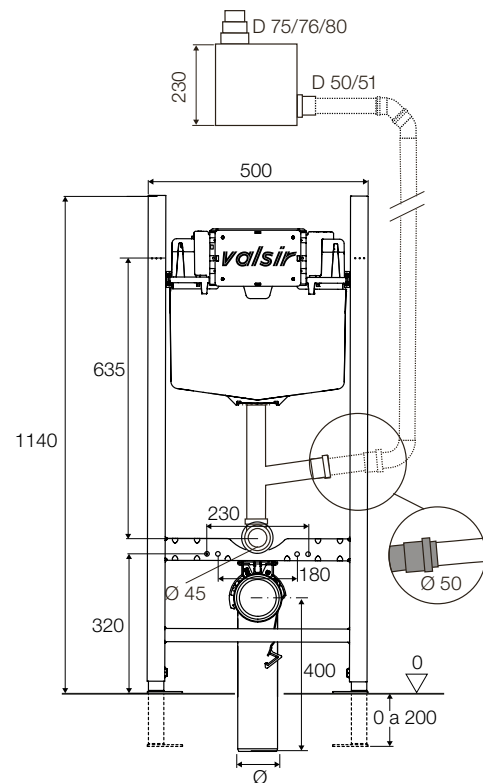

- **Tipologia WC:** sospeso
- **Tipologia installazione:** a secco, legno
- **Sistema Ariapur:** incluso
- **Volume scarico:** 6/3 (pre-regolato), 4,5/3, 4/2 l
- **Posizione placca:** frontale
- **Materiale fissaggio:** incluso
- **Kit tubi pneumatico remoto:** non incluso

- **WC type:** wall-hung pans
- **Installation:** dry walls, stud frame walls
- **Ariapur system:** included
- **Flush volume:** 6/3 (standard setting), 4.5/3, 4/2 l
- **Plate position:** front
- **Fixing material:** included
- **Pneumatic hoses kit for remote installation:** not included

- **Typologie WC :** suspendu
- **Typologie installation :** à sec, bois
- **Système Ariapur :** inclus
- **Volume chasse d'eau :** 6/3 (pré-réglé), 4,5/3, 4/2 l
- **Emplacement command :** frontal
- **Matériel de fixation :** inclus
- **Kit tuyaux pneumatique à distance :** non inclus

COD.	Mod.	Rivestimento Covering - Revêtement	SxLxH	Curva Bend - Coude	
VS0853321	mec	foderina - lining - gaine	120x500x1140	Ø 90 - L 400	1
VS0853371	pneu	foderina - lining - gaine	120x500x1140	Ø 90 - L 400	1

Raccordi di passaggio per lo scarico a pagina 91. - Fittings for connection to waste at page 91. - Raccords de passage pour l'évacuation page 91.

	Pz - Pcs	HxLxP	kg	m <sup>3</sup>
1	1	1185x805x175	15	0,17

	Pz - Pcs	HxLxP	kg	m <sup>3</sup>
6	6	1300x800x1200	98	1,25

# BLOCK AUTOPORTANTE - H 800

FREE-STANDING BLOCK - BLOCK AUTOPORTANT

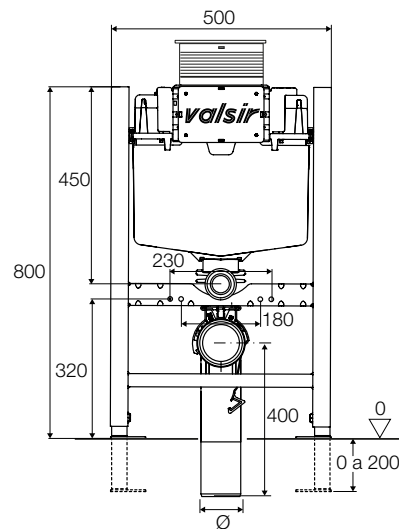

# S160



- **Tipologia WC:** sospeso
- **Tipologia installazione:** a pavimento
- **Volume scarico:** 6/3 (pre-regolato), 4,5/3, 4/2 l
- **Posizione placca:** frontale o superiore
- **Materiale fissaggio:** incluso
- **Kit tubi pneumatico remoto:** non incluso

- **WC type:** wall-hung pans
- **Installation:** anchored to the floor in dry walls
- **Flush volume:** 6/3 (standard setting), 4.5/3, 4/2 l
- **Plate position:** front or top
- **Fixing material:** included
- **Pneumatic hoses kit for remote installation:** not included

- **Typologie WC :** suspendu
- **Typologie installation :** au plancher
- **Volume chasse d'eau :** 6/3 (pré-réglé), 4,5/3, 4/2 l
- **Emplacement command :** frontal or supérieur
- **Matériel de fixation :** inclus
- **Kit tuyaux pneumatique à distance :** non inclus

COD.	Mod.	Rivestimento Covering - Revêtement	SxLxH	Curva Bend - Coude	
 VS0853445	mec	foderina - lining - gaine	160x500x800	Ø 90 - L 400	1
 VS0853475	pneu	foderina - lining - gaine	160x500x800	Ø 90 - L 400	1

Raccordi di passaggio per lo scarico a pagina 91. - Fittings for connection to waste at page 91. - Raccords de passage pour l'évacuation page 91.

 Pz - Pcs	HxLxP	kg	m <sup>3</sup>
1	895x520x165	12,9	0,08

 Pz - Pcs	HxLxP	kg	m <sup>3</sup>
18	2005x800x1200	240	1,92

# BLOCK AUTOPORTANTE - H 880

## FREE-STANDING BLOCK - BLOCK AUTOPORTANT

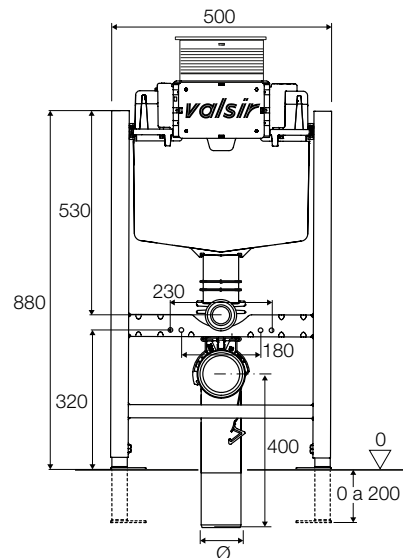

# S160



- **Tipologia WC:** sospeso
- **Tipologia installazione:** a pavimento
- **Volume scarico:** 6/3 (pre-regolato), 4,5/3, 4/2 l
- **Posizione placca:** frontale o superiore
- **Materiale fissaggio:** incluso
- **Kit tubi pneumatico remoto:** non incluso

- **WC type:** wall-hung pans
- **Installation:** anchored to the floor in dry walls
- **Flush volume:** 6/3 (standard setting), 4.5/3, 4/2 l
- **Plate position:** front or top
- **Fixing material:** included
- **Pneumatic hoses kit for remote installation:** not included

- **Typologie WC :** suspendu
- **Typologie installation :** au plancher
- **Volume chasse d'eau :** 6/3 (pré-réglé), 4,5/3, 4/2 l
- **Emplacement command :** frontal or supérieur
- **Matériel de fixation :** inclus
- **Kit tuyaux pneumatique à distance :** non inclus

COD.	Mod.	Rivestimento Covering - Revêtement	SxLxH	Curva Bend - Coude	
 VS0853411	mec	foderina - lining - gaine	160x500x880	Ø 90 - L 400	1
 VS0853461	pneu	foderina - lining - gaine	160x500x880	Ø 90 - L 400	1

Raccordi di passaggio per lo scarico a pagina 91. - Fittings for connection to waste at page 91. - Raccords de passage pour l'évacuation page 91.

 Pz - Pcs	HxLxP	kg	m <sup>3</sup>
1	895x520x165	12,9	0,08

 Pz - Pcs	HxLxP	kg	m <sup>3</sup>
18	2005x800x1200	240	1,92

# BLOCK AUTOPORTANTE - H 1140 S160



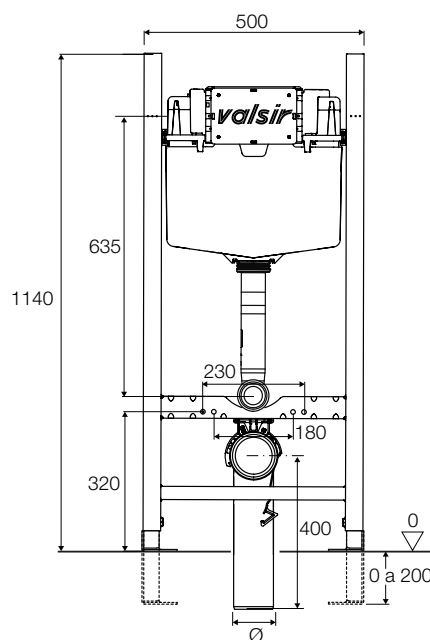

## FREE-STANDING BLOCK - BLOCK AUTOPORTANT



- **Tipologia WC:** sospeso
- **Tipologia installazione:** a pavimento
- **Volume scarico:** 6/3 (pre-regolato), 4,5/3, 4/2 l
- **Posizione placca:** frontale
- **Materiale fissaggio:** incluso
- **Kit tubi pneumatico remoto:** non incluso

- **WC type:** wall-hung pans
- **Installation:** anchored to the floor in dry walls
- **Flush volume:** 6/3 (standard setting), 4.5/3, 4/2 l
- **Plate position:** front
- **Fixing material:** included
- **Pneumatic hoses kit for remote installation:** not included

- **Typologie WC :** suspendu
- **Typologie installation :** au plancher
- **Volume chasse d'eau :** 6/3 (pré-réglé), 4,5/3, 4/2 l
- **Emplacement command :** frontal
- **Matériel de fixation :** inclus
- **Kit tuyaux pneumatique à distance :** non inclus

COD.	Mod.	Rivestimento Covering - Revêtement	SxLxH	Curva Bend - Coude	
 VS0853401	mec	foderina - lining - gaine	160x500x1140	Ø 90 - L 400	1
 VS0853451	pneu	foderina - lining - gaine	160x500x1140	Ø 90 - L 400	1
 VS0853421	electro	foderina - lining - gaine	160x500x1140	Ø 90 - L 400	1

Raccordi di passaggio per lo scarico a pagina 91. - Fittings for connection to waste at page 91. - Raccords de passage pour l'évacuation page 91.

 Pz - Pcs	HxLxP	kg	m <sup>3</sup>
1	1155x520x150	12,9	0,09

 Pz - Pcs	HxLxP	kg	m <sup>3</sup>
11	1280x800x1200	150	1,23

# BLOCK AUTOPORTANTE - H 1140 S160

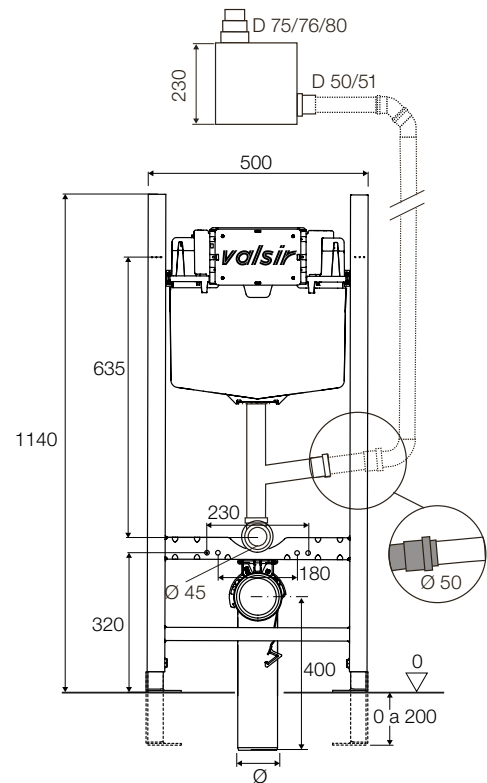

FREE-STANDING BLOCK - BLOCK AUTOPORTANT

**ARIAPUR**



- **Tipologia WC:** sospeso
- **Tipologia installazione:** a pavimento
- **Sistema Ariapur:** incluso
- **Volume scarico:** 6/3 (pre-regolato), 4,5/3, 4/2 l
- **Posizione placca:** frontale
- **Materiale fissaggio:** incluso
- **Kit tubi pneumatico remoto:** non incluso

- **WC type:** wall-hung pans
- **Installation:** anchored to the floor in dry walls
- **Ariapur system:** included
- **Flush volume:** 6/3 (standard setting), 4.5/3, 4/2 l
- **Plate position:** front or top
- **Fixing material:** included
- **Pneumatic hoses kit for remote installation:** not included

- **Typologie WC :** suspendu
- **Typologie installation :** au plancher
- **Système Ariapur :** inclus
- **Volume chasse d'eau :** 6/3 (pré-réglé), 4,5/3, 4/2 l
- **Emplacement command :** frontal
- **Matériel de fixation :** inclus
- **Kit tuyaux pneumatique à distance :** non inclus

COD.	Mod.	Rivestimento Covering - Revêtement	SxLxH	Curva Bend - Coude	
 VS0853331	mec	foderina - lining - gaine	160	Ø 90 - L 400	1
 VS0853381	pneu	foderina - lining - gaine	160	Ø 90 - L 400	1

Raccordi di passaggio per lo scarico a pagina 91. - Fittings for connection to waste at page 91. - Raccords de passage pour l'évacuation page 91.

 Pz - Pcs	HxLxP	kg	m <sup>3</sup>
1	1185x805x175	15	0,17

 Pz - Pcs	HxLxP	kg	m <sup>3</sup>
6	1300x800x1200	98	1,25



Lined writing area with 20 horizontal lines. The top 10 lines are pre-filled with the following icons from left to right: a vertical bar, a swastika, a crescent moon, a flame, a bird, a teardrop, a stylized 'U' shape, a water drop, and a triangle.



## CUBIK S: LA CASSETTA DI RISCIACQUO COMPATTA E SILENZIOSA

### CUBIK S: THE COMPACT AND SILENT FLUSH CISTERN

### CUBIK S : LE RÉSERVOIR DE CHASSE COMPACT ET SILENCIEUX

#### CARATTERISTICHE

- Il materiale del contenitore assicura un elevato assorbimento delle vibrazioni acustiche.
- Possibilità di installazione a 2 diverse altezze: 880 e 1060 mm.
- Installazione in spazi estremamente contenuti: solo 300 mm di larghezza.
- I materiali dei componenti interni ostacolano la formazione del calcare.
- Il raccordo d'alimentazione girevole facilita e velocizza l'installazione.
- Componenti interni unificati con Tropea S e Winner S.
- Placche installabili nella versione meccanica e pneumatica, sia frontale che dall'alto.
- I componenti interni sono certificati secondo la ISO EN 3822 in classe I di silenziosità a 3 e 5 bar.
- La regolazione dello scarico è a 6/3 e 4.5/3 nel rispetto della salvaguardia delle risorse e dei principi del green building.

#### CHARACTERISTICS

- The material used for the tank ensures a high vibration absorption.
- Flexibility of installation; it can be installed at 2 different heights: 880 and 1060 mm.
- It fits also in narrow spaces, only 300 mm depth.
- Internal component materials prevent the conformation of limescale.
- Swivelling connection fitting makes installation easier and quicker.
- Same internal components as Tropea S and Winner S.
- Pneumatic and mechanical flush plates can be installed either in-wall or under the counter (from above or from the front).
- Internal components compliant with the ISO EN 3822 noise level class I certification at 3 and 5 bar.
- According to the Green Building philosophy flush volume of 6/3 and 4.5/3 liters in order to reduce water consumption.

#### CARACTÉRISTIQUES

- Le matériel du boîtier assure une absorption élevée des vibrations sonores.
- Possibilité d'installation selon 2 hauteurs différentes : 880 et 1060 mm.
- Espace d'installation très réduit : une largeur de 300 mm est bien suffisante.
- Les matériaux des composants internes empêchent la formation du calcaire.
- Le raccord d'alimentation pivotant facilite et accélère l'installation.
- Composants internes standardisés avec Tropea S et Winner S.
- Plaques pouvant être installées en version mécanique et pneumatique, aussi bien en face que depuis le haut, et électronique.
- Les composants internes sont certifiés selon la norme ISO EN 3822 avec classe I de niveau de bruit à 3 et 5 bars.
- Le réglage de chasse d'eau est à 6/3 et 4.5/3, conformément aux normes de sauvegarde des ressources et des principes d'une approche écologique de la construction.

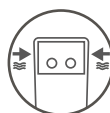
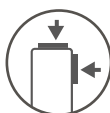
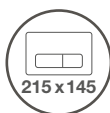

# MURARE - H 880

IN-WALL - À ENCASTRER

# S195

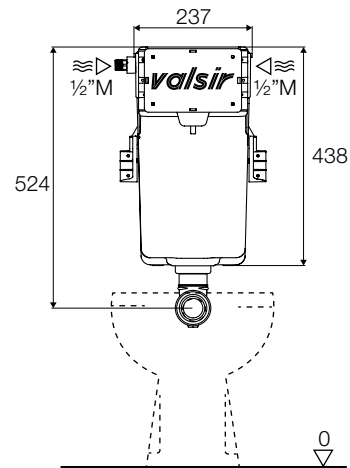



- **Tipologia WC:** a terra
- **Tipologia installazione:** mattoni, a secco, legno
- **Volume scarico:** 6/3 (pre-regolato), 4,5/3 l
- **Posizione placca:** frontale o superiore
- **Materiale fissaggio:** incluso
- **Kit tubi pneumatico remoto:** non incluso

- **WC type:** floor standing pans
- **Installation:** masonry walls, dry walls, stud frame walls
- **Flush volume:** 6/3 (standard setting), 4.5/3 l
- **Plate position:** front or top
- **Fixing material:** included
- **Pneumatic hoses kit for remote installation:** not included

- **Typologie WC :** au sol
- **Typologie installation :** briques, à sec, bois
- **Volume chasse d'eau :** 6/3 (pré-réglé), 4,5/3, 4/2 l
- **Emplacement command :** frontal or supérieur
- **Matériel de fixation :** inclus
- **Kit tuyaux pneumatique à distance :** non inclus

COD.	Mod.	Rivestimento Covering - Revêtement	SxLxH	
 VS0855004	mec	foderina - lining - gaine	195x237x438	1
 VS0855054	pneu	foderina - lining - gaine	195x237x438	1

 Pz - Pcs	HxLxP	kg	m <sup>3</sup>
1	220x615x265	3	0,34

 Pz - Pcs	HxLxP	kg	m <sup>3</sup>
54	2020x800x1200	170	1,9

# MURARE - H 1060

IN-WALL - À ENCASTRER

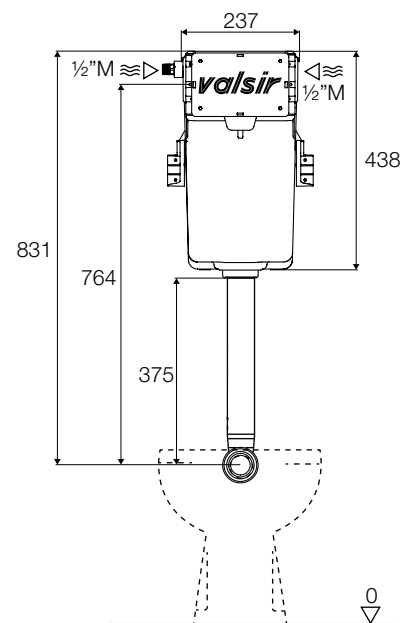

# S195





- **Tipologia WC:** a terra
- **Tipologia installazione:** mattoni, a secco, legno
- **Volume scarico:** 6/3 (pre-regolato), 4,5/3 l
- **Posizione placca:** frontale o superiore
- **Materiale fissaggio:** incluso
- **Kit tubi pneumatico remoto:** non incluso

- **WC type:** floor standing pans
- **Installation:** masonry walls, dry walls, stud frame walls
- **Flush volume:** 6/3 (standard setting), 4.5/3 l
- **Plate position:** front or top
- **Fixing material:** included
- **Pneumatic hoses kit for remote installation:** not included

- **Typologie WC :** au sol
- **Typologie installation :** briques, à sec, bois
- **Volume chasse d'eau :** 6/3 (pré-réglé), 4,5/3 l
- **Emplacement command :** frontal or supérieur
- **Matériel de fixation :** inclus
- **Kit tuyaux pneumatique à distance :** non inclus

COD.	Mod.	Rivestimento Covering - Revêtement	SxLxH	
 VS0855002	mec	foderina - lining - gaine	195x237x438	1
 VS0855052	pneu	foderina - lining - gaine	195x237x438	1

 Pz - Pcs	HxLxP	kg	m <sup>3</sup>
1	220x615x265	3	0,34

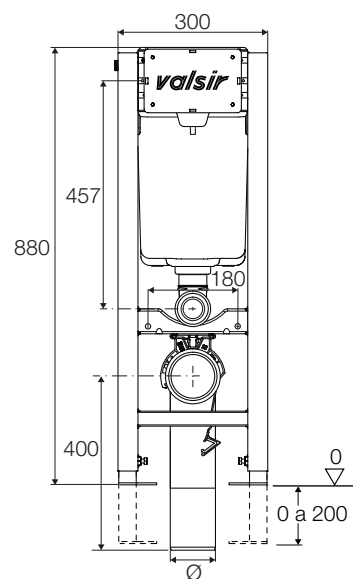

 Pz - Pcs	HxLxP	kg	m <sup>3</sup>
54	2020x800x1200	170	1,9



- **Tipologia WC:** sospeso
- **Tipologia installazione:** a secco, legno
- **Volume scarico:** 6/3 (pre-regolato), 4,5/3 l
- **Posizione placca:** frontale o superiore
- **Materiale fissaggio:** incluso
- **Kit tubi pneumatico remoto:** non incluso

- **WC type:** wall-hung pans
- **Installation:** dry walls, stud frame walls
- **Flush volume:** 6/3 (standard setting), 4,5/3 l
- **Plate position:** front or top
- **Fixing material:** included
- **Pneumatic hoses kit for remote installation:** not included

- **Typologie WC :** suspendu
- **Typologie installation :** à sec, bois
- **Volume chasse d'eau :** 6/3 (pré-réglé), 4,5/3 l
- **Emplacement command :** frontal or supérieur
- **Matériel de fixation :** inclus
- **Kit tuyaux pneumatique à distance :** non inclus

COD.	Mod.	Rivestimento Covering - Revêtement	SxLxH	Curva Bend - Coude	
 VS0855211	mec	foderina - lining - gaine	195x300x880	Ø 90 - L 400	1
 VS0855261	pneu	foderina - lining - gaine	195x300x880	Ø 90 - L 400	1

Raccordi di passaggio per lo scarico a pagina 91. - Fittings for connection to waste at page 91. - Raccords de passage pour l'évacuation page 91.

 Pz - Pcs	HxLxP	kg	m <sup>3</sup>
1	1080x325x200	16,5	0,07

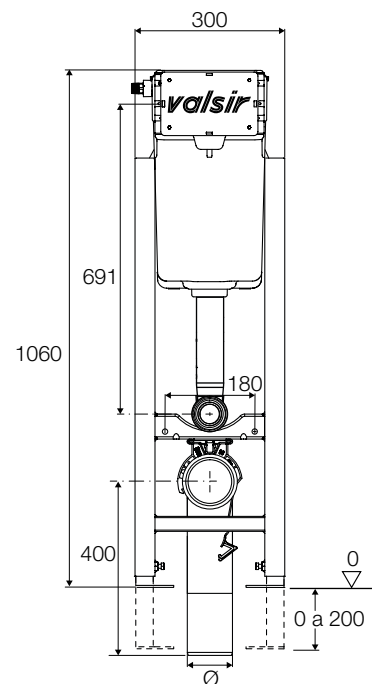

 Pz - Pcs	HxLxP	kg	m <sup>3</sup>
12	1280x800x1200	206	1,23



- **Tipologia WC:** sospeso
- **Tipologia installazione:** a secco, legno
- **Volume scarico:** 6/3 (pre-regolato), 4,5/3 l
- **Posizione placca:** frontale o superiore
- **Materiale fissaggio:** incluso
- **Kit tubi pneumatico remoto:** non incluso

- **WC type:** wall-hung pans
- **Installation:** dry walls, stud frame walls
- **Flush volume:** 6/3 (standard setting), 4.5/3 l
- **Plate position:** front or top
- **Fixing material:** included
- **Pneumatic hoses kit for remote installation:** not included

- **Typologie WC :** suspendu
- **Typologie installation :** à sec, bois
- **Volume chasse d'eau :** 6/3 (pré-réglé), 4,5/3 l
- **Emplacement command :** frontal or supérieur
- **Matériel de fixation :** inclus
- **Kit tuyaux pneumatique à distance :** non inclus

COD.	Mod.	Rivestimento Covering - Revêtement	SxLxH	Curva Bend - Coude	
 VS0855201	mec	foderina - lining - gaine	195x300x1060	Ø 90 - L 400	1
 VS0855251	pneu	foderina - lining - gaine	195x300x1060	Ø 90 - L 400	1

Raccordi di passaggio per lo scarico a pagina 91. - Fittings for connection to waste at page 91. - Raccords de passage pour l'évacuation page 91.

 Pz - Pcs	HxLxP	kg	m <sup>3</sup>
1	1080x325x200	16,5	0,07

 Pz - Pcs	HxLxP	kg	m <sup>3</sup>
12	1280x800x1200	206	1,23

# BLOCK AUTOPORTANTE - H 880

## FREE-STANDING BLOCK - BLOCK AUTOPORTANT

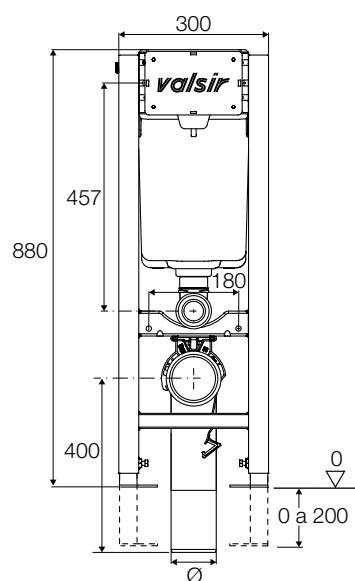

# S195



- **Tipologia WC:** sospeso
- **Tipologia installazione:** a pavimento
- **Volume scarico:** 6/3 (pre-regolato), 4,5/3 l
- **Posizione placca:** frontale o superiore
- **Materiale fissaggio:** incluso
- **Kit tubi pneumatico remoto:** non incluso

- **WC type:** wall-hung pans
- **Installation:** anchored to the floor in dry walls
- **Flush volume:** 6/3 (standard setting), 4.5/3 l
- **Plate position:** front or top
- **Fixing material:** included
- **Pneumatic hoses kit for remote installation:** not included

- **Typologie WC :** suspendu
- **Typologie installation :** au plancher
- **Volume chasse d'eau :** 6/3 (pré-réglé), 4,5/3 l
- **Emplacement command :** frontal or supérieur
- **Matériel de fixation :** inclus
- **Kit tuyaux pneumatique à distance :** non inclus

COD.	Mod.	Rivestimento Covering - Revêtement	SxLxH	Curva Bend - Coude	
 VS0855411	mec	foderina - lining - gaine	195x300x880	Ø 90 - L 400	1
 VS0855461	pneu	foderina - lining - gaine	195x300x880	Ø 90 - L 400	1

Raccordi di passaggio per lo scarico a pagina 91. - Fittings for connection to waste at page 91. - Raccords de passage pour l'évacuation page 91.

	Pz - Pcs	HxLxP	kg	m <sup>3</sup>
1	1080x325x200	16,5	0,07	

	Pz - Pcs	HxLxP	kg	m <sup>3</sup>
12	1280x800x1200	206	1,23	

# BLOCK AUTOPORTANTE - H 1060 S195

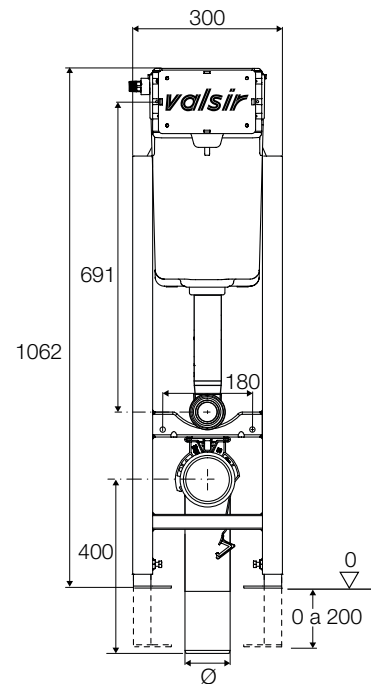

## FREE-STANDING BLOCK - BLOCK AUTOPORTANT



- **Tipologia WC:** sospeso
- **Tipologia installazione:** a pavimento
- **Volume scarico:** 6/3 (pre-regolato), 4,5/3 l
- **Posizione placca:** frontale o superiore
- **Materiale fissaggio:** incluso
- **Kit tubi pneumatico remoto:** non incluso

- **WC type:** wall-hung pans
- **Installation:** anchored to the floor in dry walls
- **Flush volume:** 6/3 (standard setting), 4.5/3 l
- **Plate position:** front or top
- **Fixing material:** included
- **Pneumatic hoses kit for remote installation:** not included

- **Typologie WC :** suspendu
- **Typologie installation :** au plancher
- **Volume chasse d'eau :** 6/3 (pré-réglé), 4,5/3 l
- **Emplacement command :** frontal or supérieur
- **Matériel de fixation :** inclus
- **Kit tuyaux pneumatique à distance :** non inclus

COD.	Mod.	Rivestimento Covering - Revêtement	SxLxH	Curva Bend - Coude	
 VS0855401	mec	foderina - lining - gaine	195x300x1060	Ø 90 - L 400	1
 VS0855451	pneu	foderina - lining - gaine	195x300x1060	Ø 90 - L 400	1

Raccordi di passaggio per lo scarico a pagina 91. - Fittings for connection to waste at page 91. - Raccords de passage pour l'évacuation page 91.

 Pz - Pcs	HxLxP	kg	m <sup>3</sup>
1	1080x325x200	16,5	0,07

 Pz - Pcs	HxLxP	kg	m <sup>3</sup>
12	1280x800x1200	206	1,23



Lined writing area with 20 horizontal lines. The top 10 lines are pre-filled with icons: a vertical bar, a swastika, a vertical bar, a flame, a bird, a crescent moon, a stylized 'E', a water drop, and a triangle.



# PLACCHECOMANDO

PUSH PLATES - PLAQUES DE COMMANDE



## PLACCHE E COMANDI: IL NATURALE COMPLEMENTO DI UNA CASSETTA VALSIR

*PUSH PLATES: THE NATURAL COMPLEMENT FOR A VALSIR CISTERN*

*PLAQUES ET COMMANDES : LE COMPLÉMENT NATUREL D'UN RÉSERVOIR DE CHASSE VALSIR*

Con uno stile rigoroso ed essenziale, Valsir abbina alle proprie cassette nelle linee Valley e Classic una serie di placche e comandi prodotti in varie finiture attraverso l'impiego di ABS o metallo.

Le placche e i comandi Valsir rispondono a criteri di massima funzionalità e assumono un ruolo rilevante nell'estetica espressa dal posizionamento del WC nel locale bagno.

Il catalogo Valsir offre innumerevoli opportunità d'arredo per abbinare alla cassetta di risciacquo una placca o un comando pneumatico che soddisfino più esigenze: praticità, risparmio d'acqua, estetica e funzionalità. Inoltre, vengono offerti una serie di accessori per garantire il massimo supporto tecnico nella scelta dei componenti.

*With a scrupulous and essential style, Valsir complements the Valley and Classic range of flush cisterns with a series of push plates and actuators in various finishes, through the use of ABS and metal.*

*The Valsir push plates and actuators satisfy criteria of maximum functionality and take on a significant role in aesthetics expressed by the position of the WC within the bathroom.*

*The Valsir catalogue offers numerous furnishing opportunities to complement the flush cistern with a push plate or pneumatic actuators, which satisfies several requirements: practicality, water saving, colour, functionality. Furthermore, a series of pneumatic mechanisms and pipe connections are offered to guarantee maximum technical support in the choice of the components.*

*Avec un style rigoureux et essentiel, Valsir combine à ses réservoirs de chasse dans les lignes Valley et Classic une série de plaques et commandes produits en différentes finitions à travers l'emploi d'ABS ou de métal.*

*Les plaques et les commandes Valsir répondent aux critères de fonctionnalité maximale et jouent un rôle important dans l'esthétique exprimée par le positionnement du WC dans la salle de bain.*

*Le catalogue Valsir offre de nombreuses opportunités de décoration pour combiner au réservoir de chasse une plaque ou une commande pneumatique qui satisfait à plusieurs exigences : ergonomie, économie d'eau, esthétique et fonctionnalité. En outre, la société offre une série d'accessoires pour garantir le maximum support technique dans le choix des composants.*







## Compatibilità placche di comando

Push plates compatibility - Compatibilité des plaques de commande

Mod.	Mat.	Dim.	Azionamento Actuating Actionnement	Cassette compatibili Compatible cisterns - Modèle réservoir		
				Tropea S	Winner S	Cubik S
 P1	ABS	215x145	mec pneu	●	●	●
 P2	ABS	215x145	mec pneu	●	●	●
 P3	ABS	215x145	mec pneu	●	●	●
 P4	ABS	215x145	mec pneu	●	●	●
 P5	ABS	215x145	mec pneu	●	●	●
 P6	METAL	245x165	mec	●	●	●
 P7	INOX/ABS65	215x145	pneu	●	●	●
 infrarossa Dual	METAL	245x165	electro	●	●	-
 Infrarossa Eye	METAL	245x165	electro	●	●	-
 Infrarossa Remote	METAL	245x165	electro	●	●	-
 ABS	ABS	245x165	mec	+ KIT VS0870230	+ KIT VS0870230	+ KIT VS0870230
 ABS	ABS	245x165	mec	+ KIT VS0870230	+ KIT VS0870230	+ KIT VS0870230
 METAL	METAL	245x165	mec	+ KIT VS0870230	+ KIT VS0870230	+ KIT VS0870230
 INOX/ABS	INOX/ABS	245x165	pneu	-	-	-











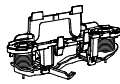



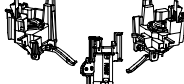





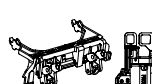

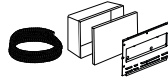

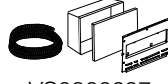

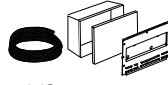
## Compatibilità comandi pneumatici con cassette pneumatiche

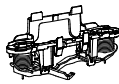
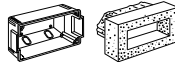
*Pneumatic actuators compatibility with pneumatic flush cisterns- Compatibilité des commandes pneumatiques avec les réservoirs de chasse pneumatiques*

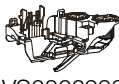
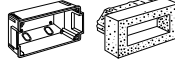
Mod.	Mat.	Dim.	Cassette compatibili Compatible cisterns - Modèle réservoir		
			Tropea S	Winner S	Cubik S
 R2	ABS	Ø 46	•	•	•
 R7	INOX/ABS	175x100 155x85	•	•	•
 R3	ABS	110x170	•	•	•
 R4	ABS	110x170	•	•	•
 R5	ABS	110x170	•	•	•
 R6	ABS	110x170	•	•	•
 SECURITY	METAL	Ø 80	•	•	•
 FOOT1	INOX	120x120	•	•	•
 FOOT2	INOX	110x160	•	•	•
 R1	ABS	105	•	•	•
	ABS	110x1110	•	•	•
	ABS	215x145	•	•	•

## Tabelle di conversione cassette

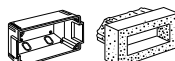
Flush cistern conversion tables - Table de conversion des réservoirs de chasse

MEC → PNEU				
TROPEA S	 TROPEA S MEC	+	 VS0866792	
WINNER S	 WINNER S MEC	+	 VS0866992	
CUBIK S	 CUBIK S MEC	+	 VS0866892	
PNEU → MEC				
TROPEA S	 TROPEA S PNEU	+	 VS0866696	
WINNER S	 WINNER S PNEU	+	 VS0866796	
CUBIK S	 CUBIK S PNEU	+	 VS0866896	
MEC → ELECTRO				
TROPEA S	 TROPEA S MEC	+	 VS0868930	+
				 VS0866697
WINNER S	 WINNER S MEC	+	 VS0868930	+
				 VS0866697
CUBIK S	 CUBIK S MEC	+	 VS0868930	+
				 VS0866697
MEC → PNEU REMOTE 2				
TROPEA S	 TROPEA S MEC	+	 VS0866792	+
			 VS0875208	+
				 VS0872206
WINNER S	 WINNER S MEC	+	 VS0866992	+
			 VS0875208	+
				 VS0872206
CUBIK S	 CUBIK S MEC	+	 VS0866892	+
			 VS0875208	+
				 VS0872206

# PLACCHE DI COMANDO MECCANICHE E PNEUMATICHE

## MECHANIC AND PNEUMATIC PUSH PLATES

### PLAQUES DE COMMANE MÉCANIQUES ET PNEUMATIQUES

P1

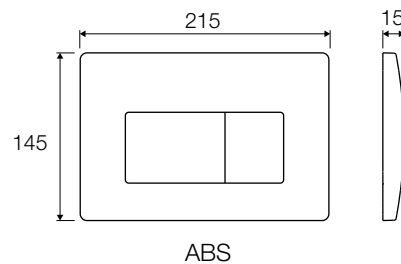

#### Meccanica - Mechanic - Mécanique

COD.	Colore - Colour - Couleur	
VS0871301	bianco - white - blanc	5
VS0871335	cromo lucido - polished chrome - chromé brillant	5
VS0871337	cromo satinato - satin chrome - chromé mat	5

Pz - Pcs	HxLxP	kg	m <sup>3</sup>
1	48x240x178	0,43	0,002

Pz - Pcs	HxLxP	kg	m <sup>3</sup>
5	195x270x245	2,2	0,013

#### Pneumatica - Pneumatic - Pneumatique

COD.	Colore - Colour - Couleur	
VS0872601	bianco - white - blanc	5
VS0872635	cromo lucido - polished chrome - chromé brillant	5
VS0872637	cromo satinato - satin chrome - chromé mat	5

Pz - Pcs	HxLxP	kg	m <sup>3</sup>
1	90x255x160	0,57	0,003

  

Pz - Pcs	HxLxP	kg	m <sup>3</sup>
5	175x465x265	3	0,022

**PLACCHE DI COMANDO**PUSH PLATES  
PLAQUES DE COMMANDE

TROPEAS WINNERS CUBIKS

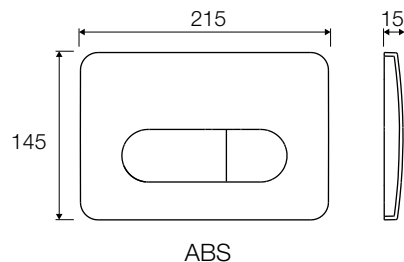
**P2****Meccanica - Mechanic - Mécanique**

<b>COD.</b>	<b>Colore - Colour - Couleur</b>	
VS0872801	bianco - white - blanc	5
VS0872835	cromo lucido - polished chrome - chromé brillant	5
VS0872837	cromo satinato - satin chrome - chromé mat	5

	<b>Pz - Pcs</b>	<b>HxLxP</b>	<b>kg</b>	<b>m<sup>3</sup></b>
	1	48x240x178	0,43	0,002

	<b>Pz - Pcs</b>	<b>HxLxP</b>	<b>kg</b>	<b>m<sup>3</sup></b>
	5	195x270x245	2,2	0,013

**Pneumatica - Pneumatic - Pneumatique**

<b>COD.</b>	<b>Colore - Colour - Couleur</b>	
VS0871501	bianco - white - blanc	5
VS0871503 •	champagne	5
VS0871517 •	visone beige - beige - vison beige	5
VS0871535	cromo lucido - polished chrome - chromé brillant	5
VS0871537	cromo satinato - satin chrome - chromé mat	5

• Ad esaurimento. - Sell out. - Fin de stock.

	<b>Pz - Pcs</b>	<b>HxLxP</b>	<b>kg</b>	<b>m<sup>3</sup></b>
	1	90x255x160	0,57	0,003

	<b>Pz - Pcs</b>	<b>HxLxP</b>	<b>kg</b>	<b>m<sup>3</sup></b>
	5	175x465x265	3	0,022

**P3**

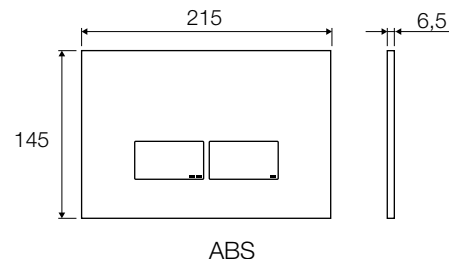

**Meccanica - Mechanic - Mécanique**

COD.	Colore - Colour - Couleur	
VS0869201	bianco - white - blanc	5
VS0869235	cromo lucido - polished chrome - chromé brillant	5
VS0869237	cromo satinato - satin chrome - chromé mat - cromo satinato	5

Pz - Pcs	HxLxP	kg	m <sup>3</sup>	Pz - Pcs	HxLxP	kg	m <sup>3</sup>
1	48x240x178	0,43	0,002	5	195x270x245	2,2	0,013

**Pneumatica - Pneumatic - Pneumatique**

COD.	Colore - Colour - Couleur	
VS0869211	bianco - white - blanc	5
VS0869245	cromo lucido - polished chrome - chromé brillant	5
VS0869247	cromo satinato - satin chrome - chromé mat	5

Pz - Pcs	HxLxP	kg	m <sup>3</sup>	Pz - Pcs	HxLxP	kg	m <sup>3</sup>
1	90x255x160	0,43	0,003	5	175x465x265	2,2	0,022

**Accessori - Accessories - Accessoires**

**Kit pulsanti per placca P3**

Button kit for P3 push plate

Kit boutons pour plaque P3

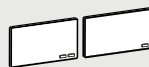

COD.	Colore - Colour - Couleur	
VS0869291	bianco - white - blanc	1
VS0869295	cromo lucido - polished chrome - chromé brillant	1
VS0869297	cromo satinato - satin chrome - chromé mat	1



## PLACCHE DI COMANDO

PUSH PLATES  
PLAQUES DE COMMANDE

TROPEAS WINNERS CUBIKS

### P4

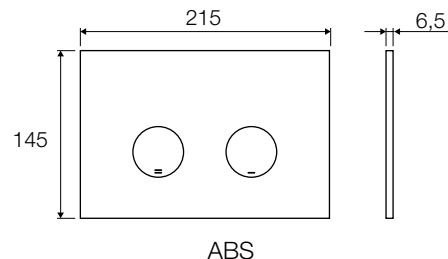

#### Meccanica - Mechanic - Mécanique

COD.	Colore - Colour - Couleur	
VS0869301	bianco - white - blanc	5
VS0869335	cromo lucido - polished chrome - chromé brillant	5
VS0869337	cromo satinato - satin chrome - chromé mat	5

Pz - Pcs	HxLxP	kg	m <sup>3</sup>	Pz - Pcs	HxLxP	kg	m <sup>3</sup>
1	48x240x178	0,43	0,002	5	195x270x245	2,2	0,013

#### Pneumatica - Pneumatic - Pneumatique

COD.	Colore - Colour - Couleur	
VS0869311	bianco - white - blanc	5
VS0869345	cromo lucido - polished chrome - chromé brillant	5
VS0869347	cromo satinato - satin chrome - chromé mat	5

Pz - Pcs	HxLxP	kg	m <sup>3</sup>	Pz - Pcs	HxLxP	kg	m <sup>3</sup>
1	90x255x160	0,43	0,003	5	175x465x265	2,2	0,022

## Accessori - Accessories - Accessoires

### Kit pulsanti per placca P4

Button kit for P4 push plate

Kit boutons pour plaque P4



COD.	Colore - Colour - Couleur	
VS0869391	bianco - white - blanc	1
VS0869395	cromo lucido - polished chrome - chromé brillant	1
VS0869397	cromo satinato - satin chrome - chromé mat	1

## P5

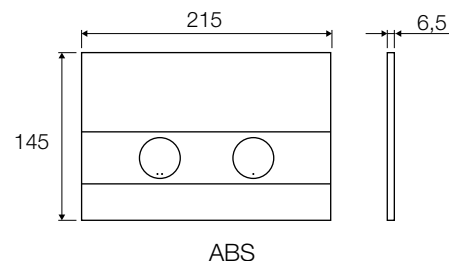

### Meccanica - Mechanic - Mécanique

COD.	Colore - Colour - Couleur	
VS0869401	bianco - white - blanc	5
VS0869402	bianco/cromo lucido* - white/polished chrome* - blanc/chromé brillant*	5
VS0869435	cromo lucido - polished chrome - chromé brillant	5
VS0869437	cromo satinato - satin chrome - chromé mat	5
VS0869404	bianco/dorato* - white/gold finish* - blanc/dorè*	5

\*Finitura della mascherina frontale. - Finishing the front plate. - Finition du cache avant.

Pz - Pcs	HxLxP	kg	m <sup>3</sup>	Pz - Pcs	HxLxP	kg	m <sup>3</sup>
1	48x240x178	0,43	0,002	5	195x270x245	2,2	0,013

### Pneumatica - Pneumatic - Pneumatique

COD.	Colore - Colour - Couleur	
VS0869411	bianco - white - blanc	5
VS0869412	bianco/cromo lucido* - white/polished chrome* - blanc/chromé brillant*	5
VS0869445	cromo lucido - polished chrome - chromé brillant	5
VS0869447	cromo satinato - satin chrome - chromé mat	5
VS0869414	bianco/dorato* - white/gold finish* - blanc/dorè*	5

\*Finitura della mascherina frontale. - Finishing the front plate. - Finition du cache avant.

Pz - Pcs	HxLxP	kg	m <sup>3</sup>	Pz - Pcs	HxLxP	kg	m <sup>3</sup>
1	90x255x160	0,43	0,003	5	175x465x265	2,2	0,022

## Accessori - Accessories - Accessoires

### Kit pulsanti per placca P5

Button kit for P5 push plate

Kit boutons pour plaque P5



COD.	Colore - Colour - Couleur	
VS0869491	bianco - white - blanc	1
VS0869495	cromo lucido - polished chrome - chromé brillant	1
VS0869497	cromo satinato - satin chrome - chromé mat	1

## PLACCHE DI COMANDO

PUSH PLATES  
PLAQUES DE COMMANDE

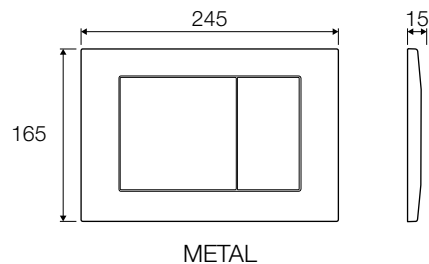

TROPEAS WINNERS CUBIKS

### P6



#### Meccanica - Mechanic - Mécanique

COD.	Colore - Colour - Couleur		
VS0870235	cromo lucido - <i>polished chrome</i> - <i>chromé brillant</i>	inviolabile - <i>tamper-proof</i> - <i>inviolables</i>	5
VS0870237	cromo satinato - <i>satin chrome</i> - <i>chromé mat</i>	inviolabile - <i>tamper-proof</i> - <i>inviolables</i>	5

	Pz - Pcs	HxLxP	kg	m <sup>3</sup>		Pz - Pcs	HxLxP	kg	m <sup>3</sup>
	1	48x270x180	1,2	0,002		5	195x275x270	6	0,015

### P7

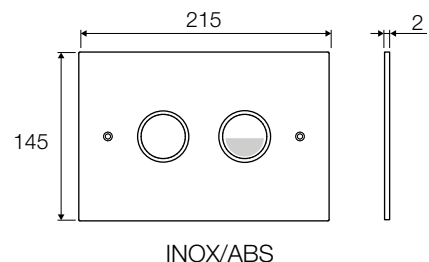

#### Pneumatica - Pneumatic - Pneumatique

COD.	Colore - Colour - Couleur		
VS0871735	inox lucido - <i>polished stainless steel</i> - <i>inox brillant</i>		1
VS0871737	inox satinato - <i>satin stainless steel</i> - <i>inox mat</i>		1

	Pz - Pcs	HxLxP	kg	m <sup>3</sup>
	1	90x255x160	0,78	0,003

# PLACCHE DI COMANDO ELETTRONICHE

ELECTRONIC PUSH PLATES

PLAQUES DE COMMANDE ÉLECTRONIQUES

## Infrarossa Dual

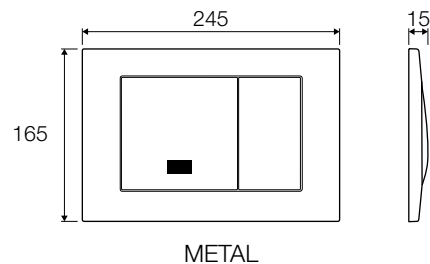

### Electronica - Electronic - Électronique

COD.	Colore - Colour - Couleur	Scarico - Flush - Débit	
VS0868901	cromo lucido - <i>polished chrome</i> - <i>chromé brillant</i>	singolo - <i>single</i> - <i>simple</i>	1

Completa di motore e cavi di alimentazione. Alimentatore da acquistare separatamente. - *Complete with motor and power cables. Power supply to be ordered separately.* - *Moteur et câbles d'alimentation inclus. Alimentateur à acheter séparément.*

 Pz - Pcs	HxLxP	kg	m <sup>3</sup>
1	120x310x210	1,5	0,0078

 Pz - Pcs	HxLxP	kg	m <sup>3</sup>
32	1140x1200x800	205	1,38

## Infrarossa Eye

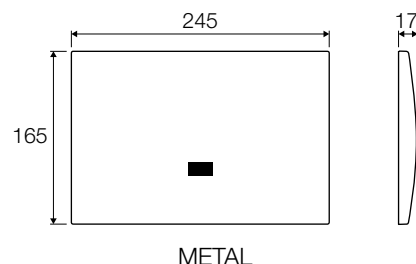

### Electronica - Electronic - Électronique

COD.	Colore - Colour - Couleur	Scarico - Flush - Débit	
VS0868911	cromo lucido - <i>polished chrome</i>	singolo - <i>single</i> - <i>simple</i>	1

Completa di motore e cavi di alimentazione. Alimentatore da acquistare separatamente. - *Complete with motor and power cables. Power supply to be ordered separately.* - *Moteur et câbles d'alimentation inclus. Alimentateur à acheter séparément.*

 Pz - Pcs	HxLxP	kg	m <sup>3</sup>
1	120x310x210	1,5	0,0078

 Pz - Pcs	HxLxP	kg	m <sup>3</sup>
32	1140x1200x800	205	1,38

## PLACCHE DI COMANDO

PUSH PLATES  
PLAQUES DE COMMANDE

TROPEAS WINNERS CUBIKS

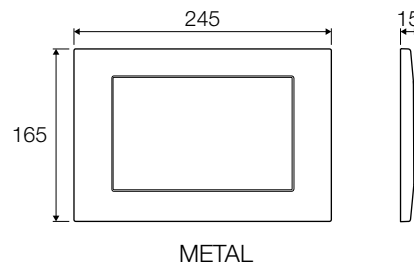

### Infrarossa Remote



### Electronica - Electronic - Électronique

COD.	Colore - Colour - Couleur	Scarico - Flush - Débit	
VS0868921	cromo lucido - polished chrome	singolo - single - simple	1

Completa di motore e cavi di alimentazione. Alimentatore da acquistare separatamente. - Complete with motor and power cables. Power supply to be ordered separately. - Moteur et câbles d'alimentation inclus. Alimentateur à acheter séparément.

 Pz - Pcs	HxLxP	kg	m <sup>3</sup>	 Pz - Pcs	HxLxP	kg	m <sup>3</sup>
1	120x310x210	1,5	0,0078	32	1140x1200x800	205	1,38

### Accessori - Accessories - Accessoires

#### Alimentatore 12 V per placca Infrarossa

Power supply 12 V for Infrarossa plate

Alimentateur 12 V pour  
plaque Infrarossa





COD.	
VS0868930	1

#### Kit predisposizione elettronico

Kit for electronic configuration

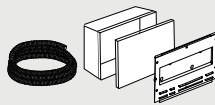
Kit prédisposition électronique



COD.	
VS0866697	1

# PLACCHE DI COMANDO PNEUMATICHE VALSIR DESIGN

VALSIR DESIGN PNEUMATIC PUSH PLATES

VALSIR DESIGN PLAQUES DE COMMANDE PNEUMATIQUE

## CRYSTAL

Rosso - Red - Rouge



	SMALL*		MEDIUM		LARGE	
<b>finiture tasti</b> <b>finishing buttons</b> <b>finitions boutons</b>						
lucido polished brillant	VS0877601	VS0877605	VS0877301	VS0877305	VS0877001	VS0877005
satinato satin satiné	VS0877603	VS0877607	VS0877303	VS0877307	VS0877003	VS0877007
	1		1		1	

\* Solo per applicazioni a comando remotato, non comprensivo del kit tubi di collegamento pneumatico remoto (VS0872206 - pag. 68) e cassa di protezione (VS0875208 - pag. 68). - For remote control applications, the kit with pneumatic remote connection hoses (VS0872206 - page 68) and in-wall box (VS0875208 - page 68) are not included in delivery scope. - Seulement pour applications à commande à distance, sans le kit tuyaux de raccordement pneumatique à distance (VS0872206 - pag. 68) et boîtier de protection (VS0875208 - page 68).

## CRYSTAL

Malesia - Malaysia - Vert pastel



	SMALL*		MEDIUM		LARGE	
<b>finiture tasti</b> <b>finishing buttons</b> <b>finitions boutons</b>						
lucido polished brillant	VS0877611	VS0877615	VS0877311	VS0877315	VS0877011	VS0877015
satinato satin satiné	VS0877613	VS0877617	VS0877313	VS0877317	VS0877013	VS0877017
	1		1		1	

\* Solo per applicazioni a comando remotato, non comprensivo del kit tubi di collegamento pneumatico remoto (VS0872206 - pag. 68) e cassa di protezione (VS0875208 - pag. 68). - For remote control applications, the kit with pneumatic remote connection hoses (VS0872206 - page 68) and in-wall box (VS0875208 - page 68) are not included in delivery scope. - Seulement pour applications à commande à distance, sans le kit tuyaux de raccordement pneumatique à distance (VS0872206 - pag. 68) et boîtier de protection (VS0875208 - page 68).

## PLACCHE DI COMANDO

PUSH PLATES  
PLAQUES DE COMMANDE

TROPEAS WINNERS CUBIKS

### CRYSTAL Ghiaccio - Ice - Glace



	SMALL*		MEDIUM		LARGE	
<b>finiture tasti</b> <b>finishing buttons</b> <b>finitions boutons</b>						
lucido polished brillant	VS0877621	VS0877625	VS0877321	VS0877325	VS0877021	VS0877025
satinato satin satiné	VS0877623	VS0877627	VS0877323	VS0877327	VS0877023	VS0877027
	1		1		1	

\* Solo per applicazioni a comando remotato, non comprensivo del kit tubi di collegamento pneumatico remoto (VS0872206 - pag. 68) e cassa di protezione (VS0875208 - pag. 68). - For remote control applications, the kit with pneumatic remote connection hoses (VS0872206 - page 68) and in-wall box (VS0875208 - page 68) are not included in delivery scope. - Seulement pour applications à commande à distance, sans le kit tuyaux de raccordement pneumatique à distance (VS0872206 - pag. 68) et boîtier de protection (VS0875208 - page 68).

### CRYSTAL Bianco Europa - Europe white - Blanc Europe



	SMALL*		MEDIUM		LARGE	
<b>finiture tasti</b> <b>finishing buttons</b> <b>finitions boutons</b>						
lucido polished brillant	VS0877631	VS0877635	VS0877331	VS0877335	VS0877031	VS0877035
satinato satin satiné	VS0877633	VS0877637	VS0877333	VS0877337	VS0877033	VS0877037
	1		1		1	

\* Solo per applicazioni a comando remotato, non comprensivo del kit tubi di collegamento pneumatico remoto (VS0872206 - pag. 68) e cassa di protezione (VS0875208 - pag. 68). - For remote control applications, the kit with pneumatic remote connection hoses (VS0872206 - page 68) and in-wall box (VS0875208 - page 68) are not included in delivery scope. - Seulement pour applications à commande à distance, sans le kit tuyaux de raccordement pneumatique à distance (VS0872206 - pag. 68) et boîtier de protection (VS0875208 - page 68).

**CRYSTAL**

**Bianco RAL 9010 - RAL 9010 white - Blanc RAL 9010**



	SMALL*		MEDIUM		LARGE	
<b>finiture tasti</b> <b>finishing buttons</b> <b>finitions boutons</b>						
lucido polished brillant	VS0877641	VS0877645	VS0877341	VS0877345	VS0877041	VS0877045
satinato satin satiné	VS0877643	VS0877647	VS0877343	VS0877347	VS0877043	VS0877047
	1		1		1	

\* Solo per applicazioni a comando remotato, non comprensivo del kit tubi di collegamento pneumatico remoto (VS0872206 - pag. 68) e cassa di protezione (VS0875208 - pag. 68). - For remote control applications, the kit with pneumatic remote connection hoses (VS0872206 - page 68) and in-wall box (VS0875208 - page 68) are not included in delivery scope. - Seulement pour applications à commande à distance, sans le kit tuyaux de raccordement pneumatique à distance (VS0872206 - pag. 68) et boîtier de protection (VS0875208 - page 68).

**CRYSTAL**

**Nero - Black - Noir**



	SMALL*		MEDIUM		LARGE	
<b>finiture tasti</b> <b>finishing buttons</b> <b>finitions boutons</b>						
lucido polished brillant	VS0877651	VS0877655	VS0877351	VS0877355	VS0877051	VS0877055
satinato satin satiné	VS0877653	VS0877657	VS0877353	VS0877357	VS0877053	VS0877057
	1		1		1	

\* Solo per applicazioni a comando remotato, non comprensivo del kit tubi di collegamento pneumatico remoto (VS0872206 - pag. 68) e cassa di protezione (VS0875208 - pag. 68). - For remote control applications, the kit with pneumatic remote connection hoses (VS0872206 - page 68) and in-wall box (VS0875208 - page 68) are not included in delivery scope. - Seulement pour applications à commande à distance, sans le kit tuyaux de raccordement pneumatique à distance (VS0872206 - pag. 68) et boîtier de protection (VS0875208 - page 68).



**PLACCHE DI COMANDO**

PUSH PLATES

PLAQUES DE COMMANDE

TROPEAS WINNERS CUBIKS

**CRYSTAL****Grigio perla - Pearl grey - Gris perle**

MEDIUM

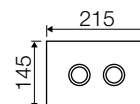
**finiture tasti**  
**finishing buttons**  
**finitions boutons**

lucido - polished - brillant

VS0877361

VS0877365

satinato - satin - satiné

VS0877363

VS0877367

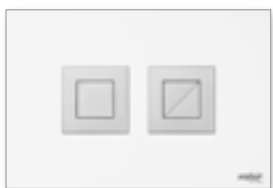

1

**CRYSTAL****Bianco Europa satinato - Satin Europe white - Satin blanc Europe**

MEDIUM

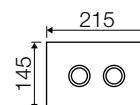
**finiture tasti**  
**finishing buttons**  
**finitions boutons**

lucido - polished - brillant

VS0877332

VS0877336

satinato - satin - satiné

VS0877334

VS0877338



1

**CRYSTAL****Bianco RAL 9010 satinato - Satin RAL 9010 white - Satin blanc RAL 9010**

MEDIUM

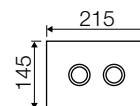
**finiture tasti**  
**finishing buttons**  
**finitions boutons**

lucido - polished - brillant

VS0877342

VS0877346

satinato - satin - satiné

VS0877344

VS0877348



1

## CRYSTAL

### Nero satinato - *Satin black* - *Satin noir*



MEDIUM

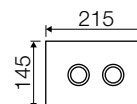

**finiture tasti**  
**finishing buttons**  
**finitions boutons**



lucido - *polished* - *brillant*

VS0877352

VS0877356

satinato - *satin* - *satiné*

VS0877354

VS0877358



1

## CRYSTAL

### Grigio perla satinato - *Satin pearl grey* - *Satin gris perle*



MEDIUM

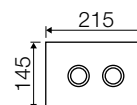

**finiture tasti**  
**finishing buttons**  
**finitions boutons**



lucido - *polished* - *brillant*

VS0877362

VS0877366

satinato - *satin* - *satiné*

VS0877364

VS0877368



1

**PLACCHE DI COMANDO**PUSH PLATES  
PLAQUES DE COMMANDE

TROPEAS WINNERS CUBIKS

**BLACK & WHITE**  
**AC bianco - AC white - AC blanc**

Made with

**DuPont™ CORIAN®**  
Glacier white

MEDIUM

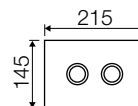
**finiture tasti**  
**finishing buttons**  
**finitions boutons**

lucido - polished - brillant

VS0878860

VS0878862

satinato - satin - satiné

VS0878861

VS0878863



1

**BLACK & WHITE**  
**AC nero - AC black - AC noir**

Made with

**DuPont™ CORIAN®**  
Nocturne

MEDIUM

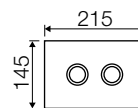
**finiture tasti**  
**finishing buttons**  
**finitions boutons**

lucido - polished - brillant

VS0878864

VS0878866

satinato - satin - satiné

VS0878865

VS0878867



1

**BLACK & WHITE**  
**AL nero - AL black - AL noir**

MEDIUM

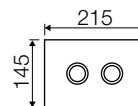
**finiture tasti**  
**finishing buttons**  
**finitions boutons**

lucido - polished - brillant

VS0878868

VS0878870

satinato - satin - satiné

VS0878869

VS0878871



1

## INOX

### Cromo lucido - *Polished chrome - Chromé brillant*

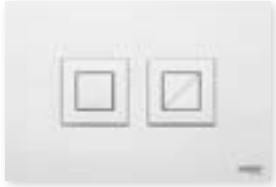

	SMALL*		MEDIUM		LARGE	
<b>finiture tasti</b> <b>finishing buttons</b> <b>finitions boutons</b>						
lucido <i>polished</i> <i>brillant</i>	VS0877961	VS0877965	VS0877931	VS0877935	VS0877901	VS0877905
	1		1		1	

\* Solo per applicazioni a comando remotato, non comprensivo del kit tubi di collegamento pneumatico remoto (VS0872206 - pag. 68) e cassa di protezione (VS0875208 - pag. 68). - *For remote control applications, the kit with pneumatic remote connection hoses (VS0872206 - page 68) and in-wall box (VS0875208 - page 68) are not included in delivery scope.* - *Seulement pour applications à commande à distance, sans le kit tuyaux de raccordement pneumatique à distance (VS0872206 - pag. 68) et boîtier de protection (VS0875208 - page 68).*

## INOX

### Cromo satinato - *Satin chrome - Chromé mat*



	SMALL*		MEDIUM		LARGE	
<b>finiture tasti</b> <b>finishing buttons</b> <b>finitions boutons</b>						
satinato <i>satin</i> <i>satiné</i>	VS0877963	VS0877967	VS0877933	VS0877937	VS0877903	VS0877907
	1		1		1	

\* Solo per applicazioni a comando remotato, non comprensivo del kit tubi di collegamento pneumatico remoto (VS0872206 - pag. 68) e cassa di protezione (VS0875208 - pag. 68). - *For remote control applications, the kit with pneumatic remote connection hoses (VS0872206 - page 68) and in-wall box (VS0875208 - page 68) are not included in delivery scope.* - *Seulement pour applications à commande à distance, sans le kit tuyaux de raccordement pneumatique à distance (VS0872206 - pag. 68) et boîtier de protection (VS0875208 - page 68).*

**PLACCHE DI COMANDO**

PUSH PLATES  
PLAQUES DE COMMANDE

TROPEAS WINNERS CUBIKS

**WOOD**

**Zebrano - Zebrano - Zébré**



	MEDIUM		LARGE	
<b>finiture tasti</b> <b>finishing buttons</b> <b>finitions boutons</b>				
lucido - <i>polished - brillant</i>	VS0876301	VS0876305	VS0876001	VS0876005
satinato - <i>satin - satiné</i>	VS0876303	VS0876307	VS0876003	VS0876007
			1	

**WOOD**

**Rovere sbiancato - Blanc oak - Chêne pale**



	MEDIUM		LARGE	
<b>finiture tasti</b> <b>finishing buttons</b> <b>finitions boutons</b>				
lucido - <i>polished - brillant</i>	VS0876331	VS0876335	VS0876031	VS0876035
satinato - <i>satin - satiné</i>	VS0876333	VS0876337	VS0876033	VS0876037
			1	

**WOOD**

**Wengé**



	MEDIUM		LARGE	
<b>finiture tasti</b> <b>finishing buttons</b> <b>finitions boutons</b>				
lucido - <i>polished - brillant</i>	VS0876351	VS0876355	VS0876051	VS0876055
satinato - <i>satin - satiné</i>	VS0876353	VS0876357	VS0876053	VS0876057
			1	

**WOOD**

**Ebano Malindi - Malindi ebony - Ébène clair**



	MEDIUM		LARGE	
<b>finiture tasti</b> <b>finishing buttons</b> <b>finitions boutons</b>				
lucido - <i>polished - brillant</i>	VS0876311	VS0876315	VS0876011	VS0876015
satinato - <i>satin - satiné</i>	VS0876313	VS0876317	VS0876013	VS0876017
	1			

**WOOD**

**Rovere grigio - Grey oak - Chêne gris**



	MEDIUM		LARGE	
<b>finiture tasti</b> <b>finishing buttons</b> <b>finitions boutons</b>				
lucido - <i>polished - brillant</i>	VS0876341	VS0876345	VS0876041	VS0876045
satinato - <i>satin - satiné</i>	VS0876343	VS0876347	VS0876043	VS0876047
	1			

**WOOD**

**Ebano Makassar - Makassar ebony - Ébène foncé**



	MEDIUM		LARGE	
<b>finiture tasti</b> <b>finishing buttons</b> <b>finitions boutons</b>				
lucido - <i>polished - brillant</i>	VS0876321	VS0876325	VS0876021	VS0876025
satinato - <i>satin - satiné</i>	VS0876323	VS0876327	VS0876023	VS0876027
	1			

**PLACCHE DI COMANDO**

PUSH PLATES  
PLAQUES DE COMMANDE

TROPEAS WINNERS CUBIKS

**STONE**

**Antracite - Anthracite - Anthracite**



	MEDIUM		LARGE	
<b>finiture tasti</b> <b>finishing buttons</b> <b>finitions boutons</b>				
lucido - polished - brillant	VS0876801	VS0876805	VS0876601	VS0876605
satinato - satin - satiné	VS0876803	VS0876807	VS0876603	VS0876607
	1			

**STONE**

**Ardesia - Slate - Ardoise**



	MEDIUM		LARGE	
<b>finiture tasti</b> <b>finishing buttons</b> <b>finitions boutons</b>				
lucido - polished - brillant	VS0876811	VS0876815	VS0876611	VS0876615
satinato - satin - satiné	VS0876813	VS0876817	VS0876613	VS0876617
	1			

**STONE**

**Marrone - Brown - Marron**



	MEDIUM		LARGE	
<b>finiture tasti</b> <b>finishing buttons</b> <b>finitions boutons</b>				
lucido - polished - brillant	VS0876821	VS0876825	VS0876621	VS0876625
satinato - satin - satiné	VS0876823	VS0876827	VS0876623	VS0876627
	1			

## STONE

### Pietra di Gerusalemme - Jerusalem stone - Pierre de Jérusalem



	MEDIUM		LARGE	
<b>finiture tasti</b> <b>finishing buttons</b> <b>finitions boutons</b>				
lucido - polished - brillant	VS0876831	VS0876835	VS0876631	VS0876635
satinato - satin - satiné	VS0876833	VS0876837	VS0876633	VS0876637
			1	

## FANTASY

### Drappo bianco - White drapery - Drapé blanc



	MEDIUM		LARGE	
<b>finiture tasti</b> <b>finishing buttons</b> <b>finitions boutons</b>				
lucido - polished - brillant	VS0878801 •	VS0878805 •	VS0878601 •	VS0878605 •
satinato - satin - satiné	VS0878803 •	VS0878807 •	VS0878603 •	VS0878607 •
			1	

• Ad esaurimento. - Sell out. - Fin de stock.

## FANTASY

### Drappo nero - Black drapery - Drapé noir



	MEDIUM	
<b>finiture tasti</b> <b>finishing buttons</b> <b>finitions boutons</b>		
lucido - polished - brillant	VS0878811 •	VS0878815 •
satinato - satin - satiné	VS0878813 •	VS0878817 •
	1	

• Ad esaurimento. - Sell out. - Fin de stock.



**FANTASY**

**Drappo caramel - Caramel drapery - Drapé caramel**



	MEDIUM		LARGE	
<b>finiture tasti</b> <b>finishing buttons</b> <b>finitions boutons</b>				
lucido - polished - brillant	VS0878821 •	VS0878825 •	VS0878621 •	VS0878625 •
satinato - satin - satiné	VS0878823 •	VS0878827 •	VS0878623 •	VS0878627 •
				1

• Ad esaurimento. - Sell out. - Fin de stock.

**FANTASY**

**Rose - Roses - Roses**



	MEDIUM		LARGE	
<b>finiture tasti</b> <b>finishing buttons</b> <b>finitions boutons</b>				
lucido - polished - brillant	VS0878311 •	VS0878315 •	VS0878011 •	VS0878015 •
satinato - satin - satiné	VS0878313 •	VS0878317 •	VS0878013 •	VS0878017 •
				1

• Ad esaurimento. - Sell out. - Fin de stock.

**FANTASY**

**Glitter oro - Gold glitter - Feuille d'or**



	MEDIUM		LARGE	
<b>finiture tasti</b> <b>finishing buttons</b> <b>finitions boutons</b>				
lucido - polished - brillant	VS0878361 •	VS0878365 •	VS0878061 •	VS0878065 •
satinato - satin - satiné	VS0878363 •	VS0878367 •	VS0878063 •	VS0878067 •
				1

• Ad esaurimento. - Sell out. - Fin de stock.

## FANTASY

### Geometrico scuro - *Dark geometric - Géométrique*



	MEDIUM		LARGE	
<b>finiture tasti</b> <b>finishing buttons</b> <b>finitions boutons</b>				
lucido - <i>polished - brillant</i>	VS0878321 •	-	VS0878021 •	VS0878025 •
satinato - <i>satin - satiné</i>	VS0878323 •	-	VS0878023 •	VS0878027 •
				1

• Ad esaurimento. - *Sell out. - Fin de stock.*

## FANTASY

### Dicroico nero - *Black dichroic - Variation noire*



	MEDIUM		LARGE	
<b>finiture tasti</b> <b>finishing buttons</b> <b>finitions boutons</b>				
lucido - <i>polished - brillant</i>	VS0878331 •	VS0878335 •	-	VS0878035 •
satinato - <i>satin - satiné</i>	VS0878333 •	VS0878337 •	VS0878033 •	VS0878037 •
				1

• Ad esaurimento. - *Sell out. - Fin de stock.*

## FANTASY

### Fiori - *Flowers - Fleurs*



	MEDIUM		LARGE	
<b>finiture tasti</b> <b>finishing buttons</b> <b>finitions boutons</b>				
lucido - <i>polished - brillant</i>	VS0878301 •	VS0878305 •	VS0878001 •	VS0878005 •
satinato - <i>satin - satiné</i>	VS0878303 •	VS0878307 •	VS0878003 •	VS0878007 •
				1

• Ad esaurimento. - *Sell out. - Fin de stock.*

## PLACCHE DI COMANDO

PUSH PLATES  
PLAQUES DE COMMANDE

TROPEAS WINNERS CUBIKS

### FANTASY

#### Alberi - Trees - Arbres



	MEDIUM		LARGE	
<b>finiture tasti</b> <b>finishing buttons</b> <b>finitions boutons</b>				
lucido - <i>polished - brillant</i>	-	VS0878345 •	VS0878041 •	VS0878045 •
satinato - <i>satin - satiné</i>	-	VS0878347 •	VS0878043 •	VS0878047 •
			1	

• Ad esaurimento. - *Sell out. - Fin de stock.*

### FANTASY

#### Brezza - Breeze - Brise



	MEDIUM		LARGE	
<b>finiture tasti</b> <b>finishing buttons</b> <b>finitions boutons</b>				
lucido - <i>polished - brillant</i>	VS0878351 •	VS0878355 •	VS0878051 •	VS0878055 •
satinato - <i>satin - satiné</i>	VS0878353 •	VS0878357 •	VS0878053 •	VS0878057 •
			1	

• Ad esaurimento. - *Sell out. - Fin de stock.*

### Kit placca personalizzata

Bespoke kit

Kit plaque personnalisée

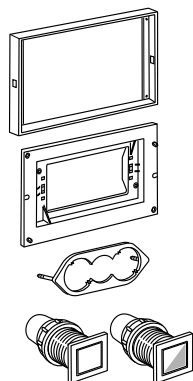

	MEDIUM		LARGE	
<b>finiture tasti</b> <b>finishing buttons</b> <b>finitions boutons</b>				
lucido - <i>polished - brillant</i>	VS0878851	VS0878853	VS0878855	VS0878857
satinato - <i>satin - satiné</i>	VS0878852	VS0878854	VS0878856	VS0878858
			1	



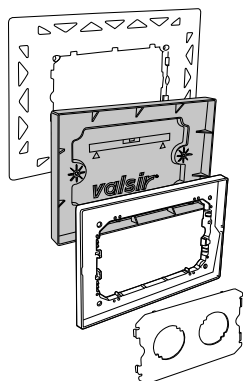

## FEEL

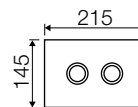

### MEDIUM



**finiture cornice**  
**finishing frame**  
**finitions cadre**

				
lucido - <i>polished</i> - <i>brillant</i>	VS0879001	VS0879005	VS0879011	VS0879015
satinato - <i>satin</i> - <i>satiné</i>	VS0879003	VS0879007	VS0879013	VS0879017
	1			

## Accessori - Accessories - Accessoires

### Kit pulsanti tondi per placche Design

Round button kit for Design push plates

Kit boutons ronds pour plaques esthétiques



<b>COD.</b>	<b>Colore - Colour - Couleur</b>	
VS0878872	nero lucido - <i>polished black</i> - <i>noir brillant</i>	1
VS0878873	bianco lucido - <i>polished white</i> - <i>blanc brillant</i>	1

### Kit pulsanti quadri per placche Design

Square button kit for Design push plates

Kit boutons carrés pour plaques esthétiques



<b>COD.</b>	<b>Colore - Colour - Couleur</b>	
VS0878874	nero lucido - <i>polished black</i> - <i>noir brillant</i>	1
VS0878875	bianco lucido - <i>polished white</i> - <i>blanc brillant</i>	1

# PLACCHE DI COMANDO LARGE (245x165 mm)

LARGE (245x165 mm) PUSH PLATES

PLAQUES DE COMMANDE LARGE (245x165 mm)

Placche compatibili con le cassette Tropea3/Tropea S/Winner S/Cubik S con adattatore VS0870230.

Plates compatible with the Tropea3/Tropea S/Winner S/Cubik S cisterns with adaptor VS0870230.

Plaques compatibles avec les réservoirs de chasse Tropea3/Tropea S/Winner S/Cubik S avec adaptateur VS0870230.

## Placca meccanica doppio scarico

Dual flush push plate, mechanical

Plaque de commande mécanique double débit

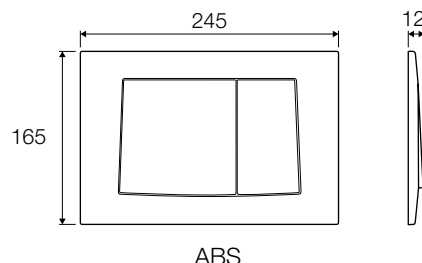

COD.	Colore - Colour - Couleur	
VS0872501	bianco - white - blanc	5
VS0872535	cromo lucido - polished chrome - chromé brillant	5
VS0872537	cromo satinato - satin chrome - chromé mat	5

Pz - Pcs	HxLxP	kg	m <sup>3</sup>	Pz - Pcs	HxLxP	kg	m <sup>3</sup>	Pz - Pcs	HxLxP	kg	m <sup>3</sup>
1	48x270x180	0,5	0,002	5	195x275x280	2,5	0,015	300	1130x800x1200	158	1,08

## Placca meccanica doppio scarico

Dual flush push plate, mechanical

Plaque de commande mécanique double débit

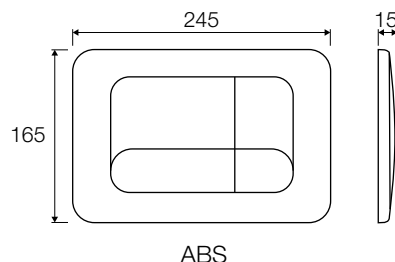
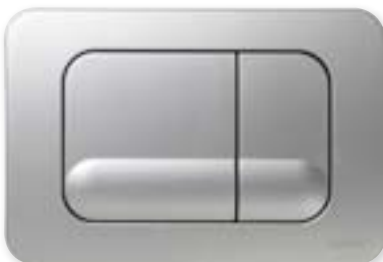

COD.	Colore - Colour - Couleur	
VS0870501	bianco - white - blanc	5
VS0870503 •	champagne	5
VS0870535	cromo lucido - polished chrome - chromé brillant	5
VS0870537	cromo satinato - satin chrome - chromé mat	5

• Ad esaurimento. - Sell out. - Fin de stock.

Pz - Pcs	HxLxP	kg	m <sup>3</sup>	Pz - Pcs	HxLxP	kg	m <sup>3</sup>	Pz - Pcs	HxLxP	kg	m <sup>3</sup>
1	48x270x180	0,5	0,002	5	195x275x280	2,5	0,015	300	1130x800x1200	158	1,08

**Placca meccanica doppio scarico**

Dual flush push plate, mechanical

Plaque de commande mécanique double débit

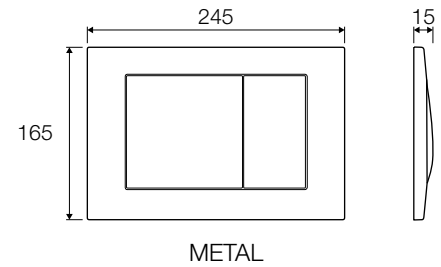

COD.	Colore - Colour - Couleur	
VS0870835	cromo lucido - polished chrome - chromé brillant	5
VS0870837	cromo satinato - satin chrome - chromé mat	5

	Pz - Pcs	HxLxP	kg	m³		Pz - Pcs	HxLxP	kg	m³		Pz - Pcs	HxLxP	kg	m³
	1	48x270x180	1,2	0,002		5	195x275x280	6	0,015		300	1130x800x1200	368	1,08

**Accessori - Accessories - Accessoires**

**Adattatore placche large (245x165 mm) meccaniche**

Adapter for large plates (245x165 mm) mechanical

Adaptateur de plaques larges (245x165 mm) mécaniques

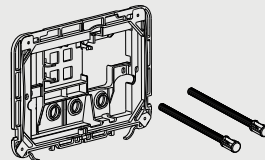

COD.		
VS0870230		1

**Placca pneumatica doppio scarico**

Dual flush pneumatic buttons

Plaque pneumatique double débit

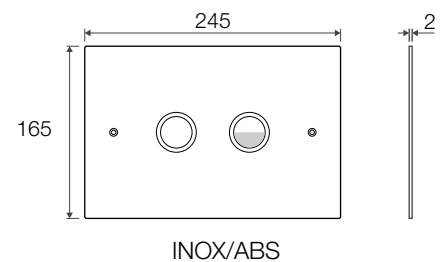

COD.	Colore - Colour - Couleur	
VS0870735	inox lucido - polished stainless steel	1
VS0870737	inox satinato - satin stainless steel	1

	Pz - Pcs	HxLxP	kg	m³
	1	110x265x180	1,00	0,005

# COMANDI PNEUMATICI NON INGOMBRO

## SPACE-SAVING PNEUMATIC ACTUATORS

### COMMANDES PNEUMATIQUES FAIBLE ENCOMBREMENT

#### R2

##### Pulsanti non ingombro scarico due quantità

Dual flush space saving buttons

Kit bouton poussoir  
faible encombrement  
évacuation partielle

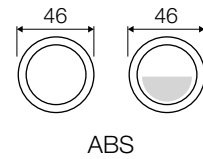

COD.	Colore - Colour - Couleur	
VS0802135	cromo lucido - polished chrome - chromé brillant	1
VS0802137	cromo satinato - satin chrome - chromé mat	1

Non comprensivo del kit tubi di collegamento pneumatico (VS0872206 - pag. 68). - The kit with pneumatic connection hoses is not included in delivery scope (VS0872206 - page 68). - Sans le kit tuyaux de raccordement pneumatique (VS0872206 - pag. 68).

Pz - Pcs	HxLxP	kg	m <sup>3</sup>
1	110x110x190	0,22	0,002

#### R7

##### Comando non ingombro con placca in metallo scarico due quantità

Dual flush space saving buttons with metal plate

Boutons poussoirs faible encombrement avec plaque métallique double touche

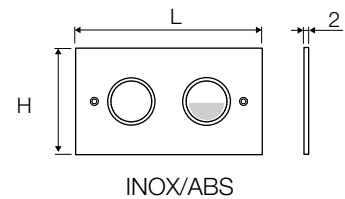

#### A murare - In-wall - A encaster

COD.	Colore - Colour - Couleur	SxLxH	
VS0872235	cromo lucido - polished chrome - chromé brillant	2x175x100	1
VS0872237	cromo satinato - satin chrome - chromé mat	2x175x100	1

#### Per cartongesso - For plasterboard - Pour plaque de plâtre.

COD.	Colore - Colour - Couleur	SxLxH	
VS0802235	cromo lucido - polished chrome - chromé brillant	2x155x85	1
VS0802237	cromo satinato - satin chrome - chromé mat	2x155x85	1

Non comprensivo del kit tubi di collegamento pneumatico (VS0872206 - pag. 68). - The kit with pneumatic connection hoses is not included in delivery scope (VS0872206 - page 68). - Sans le kit tuyaux de raccordement pneumatique (VS0872206 - pag. 68).

Pz - Pcs	HxLxP	kg	m <sup>3</sup>
1	100x110x190	0,5	0,002

### R3 Placca di scarico non ingombro con pulsanti a filo

*Space saving push plate,  
buttons flush with plate*

*Plaque de commande double  
débit faible encombrement avec  
boutons poussoirs arrasants*

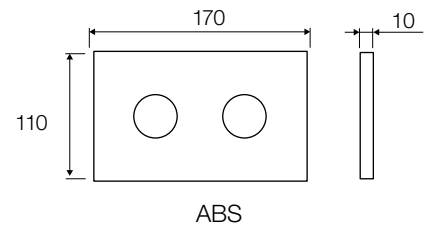

#### COD.

#### Colore - Colour - Couleur



VS0875001	bianco - white - blanc	1
VS0875035	cromo lucido - polished chrome - chromé brillant	1
VS0875037	cromo satinato - satin chrome - chromé mat	1

Non comprensivo del kit tubi di collegamento pneumatico remoto (VS0872206 - pag. 68) e cassa di protezione (VS0875208 - pag. 68). - *The kit with pneumatic remote connection hoses (VS0872206 - page 68) and in-wall box (VS0875208 - page 68) are not included in delivery scope. - Sans le kit tuyaux de raccordement pneumatique à distance (VS0872206 - page 68) et boîtier de protection (VS0875208 - page 68).*



Pz - Pcs	HxLxP	kg	m <sup>3</sup>
1	100x190x110	0,33	0,002

### R4 Placca di scarico non ingombro con pulsanti sporgenti

*Space saving push plate,  
protruding buttons*

*Plaque de commande double  
débit faible encombrement  
avec des boutons en saillie*

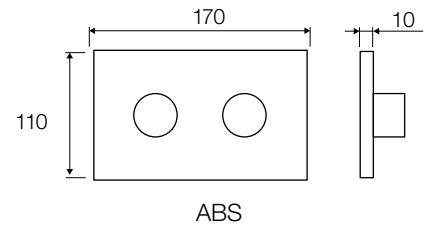

#### COD.

#### Colore - Colour - Couleur



VS0875501	bianco - white - blanc	1
VS0875535	cromo lucido - polished chrome - chromé brillant	1
VS0875537	cromo satinato - satin chrome - chromé mat	1

Non comprensivo del kit tubi di collegamento pneumatico remoto (VS0872206 - pag. 68) e cassa di protezione (VS0875208 - pag. 68). - *The kit with pneumatic remote connection hoses (VS0872206 - page 68) and in-wall box (VS0875208 - page 68) are not included in delivery scope. - Sans le kit tuyaux de raccordement pneumatique à distance (VS0872206 - page 68) et boîtier de protection (VS0875208 - page 68).*



Pz - Pcs	HxLxP	kg	m <sup>3</sup>
1	100x190x110	0,33	0,002



## Accessori - Accessories - Accessoires

### Cassa a murare completa di protezione in EPS e dima di foratura

*In-wall box with EPS protection lining and drilling template*

*Boite à encastrer*

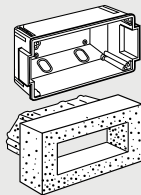

**COD.**



VS0875208

1

Solo per applicazioni a comando remotato in muratura (azionamento a distanza). - *For in-wall remote control applications.* - *Seulement pour applications à commande à distance en maçonnerie (actionnement à distance).*

### Kit tubi collegamento pneus 2 quantità, 2,5 m

*Connection pipes for pneumatic mechanism, dual flush, 2.5 m*

*Kit tubes de raccordement pneumatiques 2 quantités 2,5 m*



**COD.**



VS0872206

1

Solo per applicazioni a comando remotato (azionamento a distanza). - *For remote control applications.* - *Seulement pour applications à commande à distance (actionnement à distance).*

# COMANDI PNEUMATICI PER IPOVEDENTI

PNEUMATIC ACTUATORS FOR THE PARTIALLY SIGHTED

COMMANDES PNEUMATIQUES POUR MALVOYANTS

## R5

### Placca di scarico non ingombro con pulsanti a filo per ipovedenti

Space saving push plate, buttons flush with plate - for visually impaired users

Plaque de chasse d'eau encombrement minimum avec boutons à ras pour malvoyants

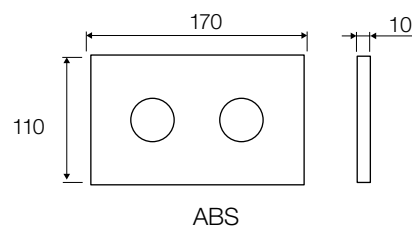

#### COD.

#### Colore - Colour - Couleur



VS0875011

bianco - white - blanc

1

VS0875047

cromo satinato - satin chrome - chromé mat

1

Non comprensivo del kit tubi di collegamento pneumatico remoto (VS0872206 - pag. 68) e cassa di protezione (VS0875208 - pag. 68). - The kit with pneumatic remote connection hoses (VS0872206 - page 68) and in-wall box (VS0875208 - page 68) are not included in delivery scope. - Sans le kit tuyaux de raccordement pneumatique à distance (VS0872206 - page 68) et boîtier de protection (VS0875208 - page 68).



Pz - Pcs	HxLxP	kg	m <sup>3</sup>
1	100x190x110	0,33	0,002

## R6

### Placca di scarico non ingombro in ABS con pulsanti sporgenti per ipovedenti

ABS space saving push plate, protruding buttons - for visually impaired users

Plaque de chasse d'eau encombrement minimum en ABS avec boutons en saillie pour malvoyants

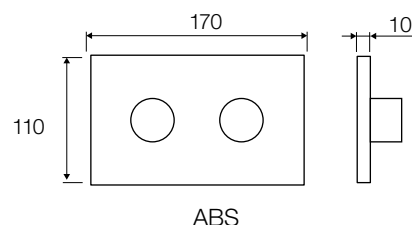

#### COD.

#### Colore - Colour - Couleur



VS0875511

bianco - white - blanc

1

VS0875547

cromo satinato - satin chrome - chromé mat

1

Non comprensivo del kit tubi di collegamento pneumatico remoto (VS0872206 - pag. 68) e cassa di protezione (VS0875208 - pag. 68). - The kit with pneumatic remote connection hoses (VS0872206 - page 68) and in-wall box (VS0875208 - page 68) are not included in delivery scope. - Sans le kit tuyaux de raccordement pneumatique à distance (VS0872206 - page 68) et boîtier de protection (VS0875208 - page 68).



Pz - Pcs	HxLxP	kg	m <sup>3</sup>
1	100x190x110	0,33	0,002

# COMANDI PNEUMATICI UNIVERSALI

UNIVERSAL PNEUMATIC ACTUATORS

COMMANDES PNEUMATIQUES UNIVERSELLES

## SECURITY

### Comando pneumatico

*Pneumatic actuator*

*Commande pneumatique*

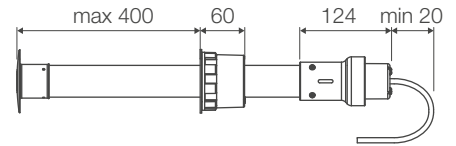

METAL

#### COD.

Colore - Colour - Couleur



VS0802455

cromo lucido - polished chrome - chromé brillant

1

Non comprensivo del kit tubi di collegamento pneumatico (VS0872204 - pag. 72). - The kit with pneumatic connection hoses is not included in delivery scope (VS0872204 - page 72). - Sans le kit tuyaux de raccordement pneumatique (VS0872204 - pag. 72).



Pz - Pcs	HxLxP	kg	m <sup>3</sup>
1	100x430x120	1	0,005

## FOOT1

### Comando pneumatico a pedale per il montaggio a pavimento

*Pneumatic foot-operated floor push button*

*Commande pneumatique au pied pour le montage au sol*

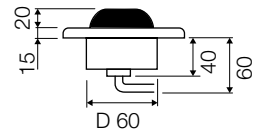
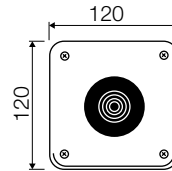

INOX

#### COD.

Colore - Colour - Couleur



VS0804801

inox lucido - polished stainless steel - acier inox

1

Completo di comando in acciaio inox e materiale di fissaggio. - Supplied with stainless steel controls and installation elements. - Avec commande en acier inox et matériel de fixation.

Non comprensivo del kit tubi di collegamento pneumatico (VS0872204 - pag. 72). - The kit with pneumatic connection hoses is not included in delivery scope (VS0872204 - page 72). - Sans le kit tuyaux de raccordement pneumatique (VS0872204 - pag. 72).



Pz - Pcs	HxLxP	kg	m <sup>3</sup>
1	100x250x160	0,45	0,004

## FOOT2

### Comando pneumatico a pedale per il montaggio a parete

*Pneumatic foot-operated wall push button*

*Commande pneumatique au pied pour le montage sur paroi*

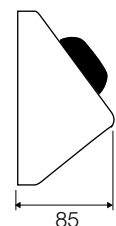
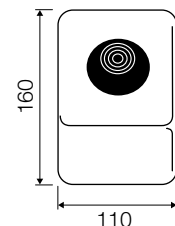

INOX

#### COD.

Colore - Colour - Couleur



VS0804901

inox lucido - polished stainless steel - acier inox

1

Completo di comando in acciaio inox e materiale di fissaggio. - Supplied with stainless steel controls and installation elements. - Avec commande en acier inox et matériel de fixation.

Non comprensivo del kit tubi di collegamento pneumatico (VS0872204 - pag. 72). - The kit with pneumatic connection hoses is not included in delivery scope (VS0872204 - page 72). - Sans le kit tuyaux de raccordement pneumatique (VS0872204 - pag. 72).



Pz - Pcs	HxLxP	kg	m <sup>3</sup>
1	100x250x160	0,73	0,004

## R1 Pulsante pneumatico ad incasso per il montaggio a parete

*In-wall pneumatic push button*

*Commande pneumatique  
à encastrer pour le  
montage sur paroi*

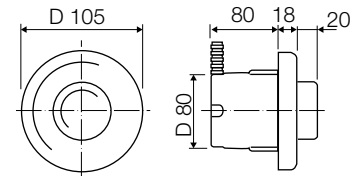

ABS

COD.	Colore - Colour - Couleur	
VS0802301	bianco - white - blanc	1
VS0802335	cromo lucido - polished chrome - chromé brillant	1
VS0802337	cromo satinato - satin chrome - chromé mat	1
VS0802338 •	dorato - gold finish - doré	1

• Ad esaurimento. - Sell out. - Fin de stock.

Completo di comando a parete e materiale di fissaggio. - Supplied with controls and installation elements. - Avec commande murale et matériel de fixation.

Non comprensivo del kit tubi di collegamento pneumatico (VS0872204 - pag. 72). - The kit with pneumatic connection hoses is not included in delivery scope (VS0872204 - page 72). - Sans le kit tuyaux de raccordement pneumatique (VS0872204 - pag. 72).



Pz - Pcs	HxLxP	kg	m <sup>3</sup>
1	120x110x110	0,21	0,0015

## Pulsante pneumatico esterno per il montaggio a parete

*External pneumatic push button*

*Commande pneumatique  
à encastrer pour le  
montage sur paroi*

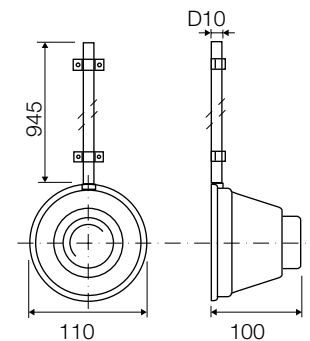

ABS

COD.	Colore - Colour - Couleur	
VS0802401	bianco - white	1
VS0802435	cromo lucido - polished chrome	1
VS0802437	cromo satinato - satin chrome	1

Completo di comando a pulsante, tubo di protezione, materiale di fissaggio e del kit tubo di collegamento pneumatico.

Supplied with push-button control, protective tube and installation elements, the kit with pneumatic connection hoses is included in delivery scope.

Avec commande à boutons, tuyau de protection, matériel de fixation et kit tuyau de raccordement pneumatique.



Pz - Pcs	HxLxP	kg	m <sup>3</sup>
1	110x120x1020	0,3	0,013

## Accessori - Accessories - Accessoires

### Cassa a murare completa di protezione in EPS e dima di foratura

*In-wall box with EPS protection lining and drilling template*

*Boite à encastrer*

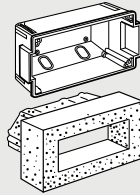

**COD.**



VS0875208

1

Solo per applicazioni a comando remotato in muratura (azionamento a distanza). - *For in-wall remote control applications.* - *Seulement pour applications à commande à distance en maçonnerie (actionnement à distance).*

### Kit tubi collegamento pneus 2 quantità, 2,5 m

*Connection pipes for pneumatic mechanism, dual flush, 2.5 m*

*Kit tubes de raccordement pneumatiques 2 quantités 2,5 m*

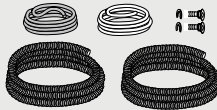

**COD.**



VS0872206

1

Solo per applicazioni a comando remotato in muratura (azionamento a distanza). - *For in-wall remote control applications.* - *Seulement pour applications à commande à distance (actionnement à distance).*

### Kit tubi collegamento pneus singolo scarico, 2,5 m

*Connection pipes for pneumatic mechanism, single flush, 2.5 m*

*Kit tubes de raccordement pneumatiques 1 quantité 2,5 m*



**COD.**



VS0872204

1

Solo per applicazioni a comando remotato in muratura (azionamento a distanza). - *For in-wall remote control applications.* - *Seulement pour applications à commande à distance (actionnement à distance).*

## Placca ispezione

Access plate

Plaque d'inspection

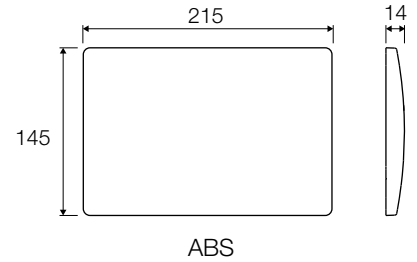

### COD.

### Colore - Colour - Couleur

COD.	Colore - Colour - Couleur	
VS0871401	bianco - white - blanc	1
VS0871435	cromo lucido - polished chrome - chromé brillant	1
VS0871437	cromo satinato - satin chrome - chromé mat	1



Pz - Pcs	HxLxP	kg	m <sup>3</sup>
1	90x255x160	0,4	0,003

## Placca ispezione

Access plate

Plaque d'inspection

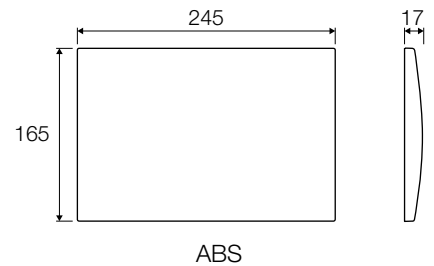

### COD.

### Colore - Colour - Couleur

COD.	Colore - Colour - Couleur	
VS0870401	bianco - white - blanc	1
VS0870435	cromo lucido - polished chrome - chromé brillant	1
VS0870437	cromo satinato - satin chrome - chromé mat	1



Pz - Pcs	HxLxP	kg	m <sup>3</sup>
1	48x270x180	0,4	0,002

## Placca ispezione

Access plate

Plaque d'inspection

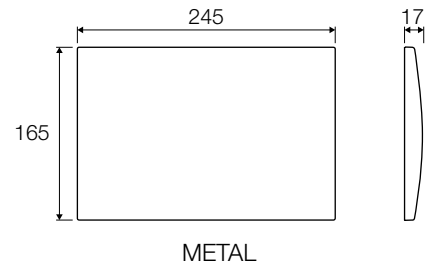

### COD.

### Colore - Colour - Couleur

COD.	Colore - Colour - Couleur	
VS0870901	bianco - white - blanc	1
VS0870935	cromo lucido - polished chrome - chromé brillant	1
VS0870937 •	cromo satinato - satin chrome - chromé mat	1

• Ad esaurimento. - Sell out. - Fin de stock.





Pz - Pcs	HxLxP	kg	m <sup>3</sup>
1	48x270x180	0,9	0,002

**Cannotto telescopico completo di rosone, morsetto e bicchiere riduzione Ø 40/45**

*Telescopic connection pipe with escutcheon, grommet and socket reducer Ø 40/45*

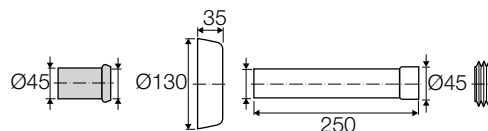
*Tube de raccordement cuvette télescopique avec rosace, joint et réduction D 40/45*





COD.	Colore - Colour - Couleur	
VS0803511	bianco - white - blanc	1
VS0803545	cromo lucido - polished chrome - chromé brillant	1
VS0803547	cromo satinato - satin chrome - chromé mat	1

**Cannotto completo di rosone e morsetto Ø 45**

*Connection pipe complete with escutcheon and grommet Ø 45*

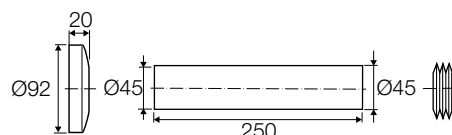
*Tube de raccordement avec rosace et joint D 45*





COD.	Colore - Colour - Couleur	
VS0803111	bianco - white - blanc	1
VS0803145	cromo lucido - polished chrome - chromé brillant	1
VS0803147	cromo satinato - satin chrome - chromé mat	1

**Cannotto prolungato completo di rosone e morsetto Ø 40 L 500**

*Extended connection pipe with escutcheon and grommet Ø 40 L 500*

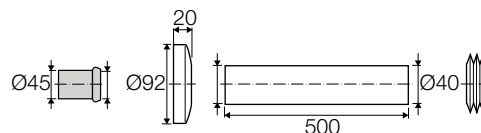
*Tube de raccordement cuvette prolongé avec rosace et joint Ø 40 L 500*



COD.	Colore - Colour - Couleur	
VS0803901	bianco - white - blanc	1

\* Da ordinare separatamente. - To be order separately. - À commander séparément. (VS0828201 - pag. 75)

## Cannotto eccentrico completo di rosone Ø 130

Offset connection pipe Ø 130 with escutcheon

Tube de raccordement excentré avec rosace Ø 130

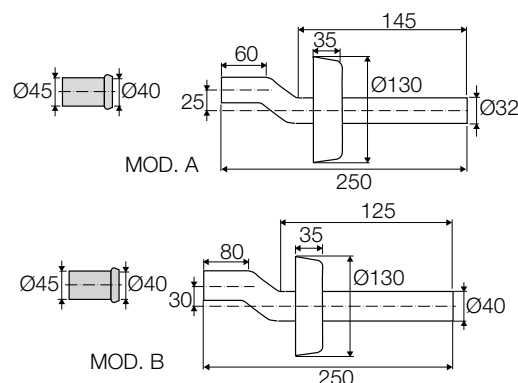

COD.	Mod.	Ø	Colore - Colour - Couleur	
VS0802601	A	32	bianco - white - blanc	10
VS0802635	A	32	cromo lucido - polished chrome - chromé brillant	10
VS0802701	B	40	bianco - white - blanc	10
VS0802735	B	40	cromo lucido - polished chrome - chromé brillant	10

\* Da ordinare separatamente. - To be order separately. - À commander séparément. (VS0828201 - pag. 75)

## Cannotto completo di rosone e morsetto Ø 40/32

Connection pipe complete with escutcheon and grommet Ø 40/32

Tube de raccordement avec rosace et joint Ø 40/32

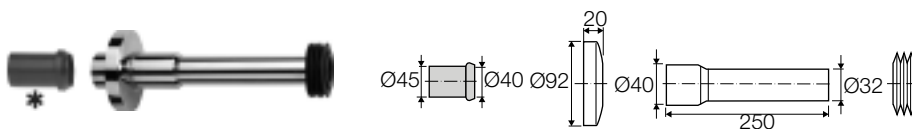

COD.	Colore - Colour - Couleur	
VS0803201	bianco - white - blanc	1
VS0803203 •	champagne	1
VS0803205 •	grigio manhattan - manhattan grey - gris manhattan	1
VS0803217 •	visone beige - beige - vison beige	1
VS0803235	cromo lucido - polished chrome - chromé brillant	1
VS0803237	cromo satinato - satin chrome - chromé mat	1
VS0803238 •	dorato - gold finish - doré	1

\* Da ordinare separatamente. - To be order separately. - À commander séparément. (VS0828201 - pag. 75)

• Ad esaurimento. - Sell out. - Fin de stock.

## Ricambi - Spare parts - Pièces de rechange

### Riduzione

Reducer

Réduction

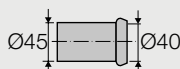

COD.	
VS0828201	1



## Cannotto completo di rosone e morsetto Ø 40

Connection pipe complete with escutcheon and grommet Ø 40

Tube de raccordement cuvette télescopique avec rosace et joint Ø 40

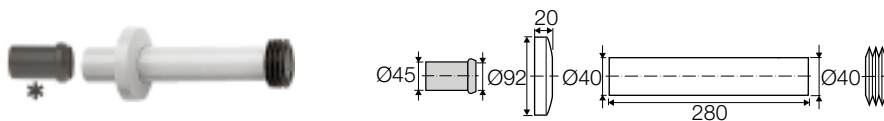

COD.	Colore - Colour - Couleur	
VS0803001	bianco - white - blanc	1
VS0803003 •	champagne	1
VS0803005 •	grigio manhattan - manhattan grey - gris manhattan	1
VS0803017 •	visone beige - beige - vison beige	1
VS0803035	cromo lucido - polished chrome - chromé brillant	1
VS0803037	cromo satinato - satin chrome - chromé mat	1
VS0803038 •	dorato - gold finish - doré	1

\* Da ordinare separatamente. - To be order separately. - À commander séparément. (VS0828201 - pag. 75)

• Ad esaurimento. - Sell out. - Fin de stock.

## Tubo flessibile con prolunga HDPE Ø 56/50

Flexible pipe with HDPE extension Ø 56/50

Tube flexible avec rallonge HDPE Ø 56/50

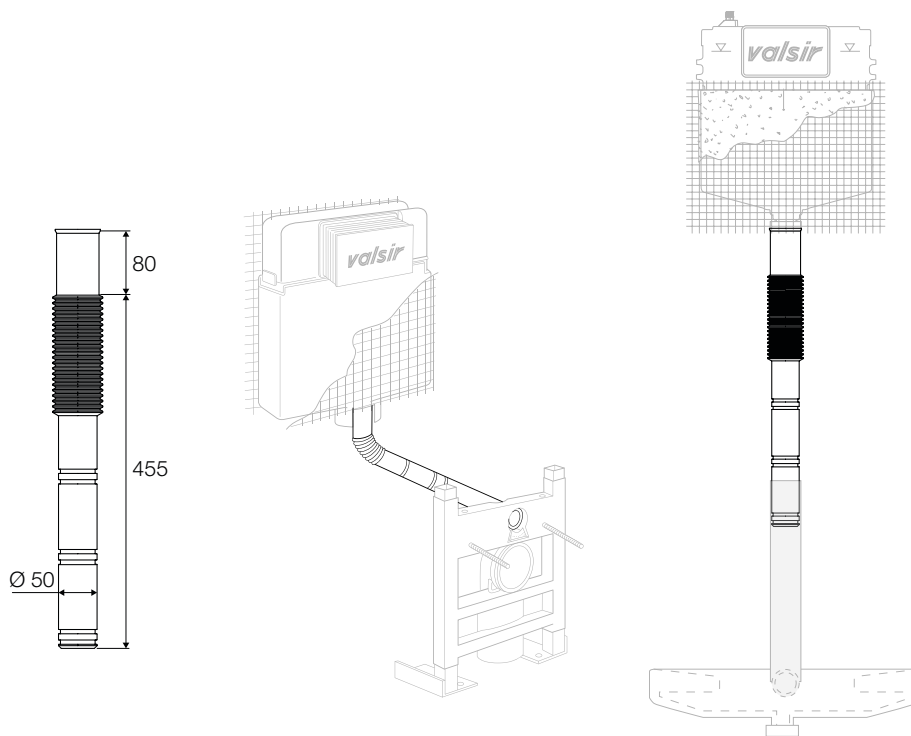

COD.	
VS0865148	1

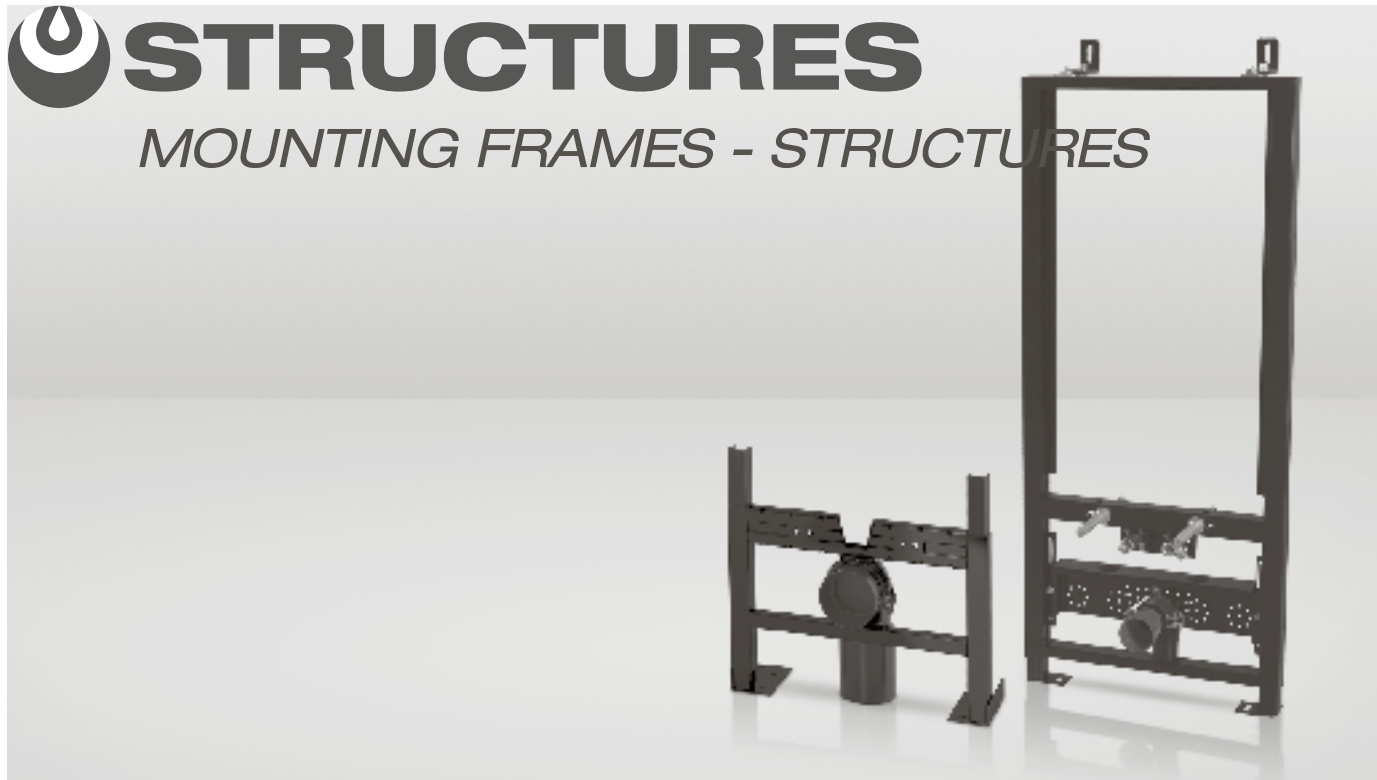

### **STRUTTURE: PER OGNI TIPOLOGIA D'INSTALLAZIONE** *MOUNTING FRAMES: FOR EVERY TYPE OF INSTALLATION* *STRUCTURES : POUR CHAQUE TYPE D'INSTALLATION*

Valsir propone tre differenti tipologie di strutture per ogni esigenza d'installazione.

La linea Fixsystem è realizzata in lamiera zincata e le linee Block e Block autoportante sono in tubolare protetto alla corrosione.

Progettate e costruite per offrire più soluzioni d'installazione, le strutture Fixsystem, Block e Block autoportante assicurano affidabilità e semplicità di montaggio.

*Valsir offers three different frame types capable of satisfying all installation requirements.*

*The Fixsystem range is made of galvanized sheet metal and the Block and free-standing Block frames are made of tubular metal protected from corrosion.*

*Designed and built to offer several installation solutions, the Fixsystem, Block and free-standing Block frames ensure reliability and easy installation.*

*Valsir propose trois différentes typologies de structures pour satisfaire à toute exigence d'installation.*

*La ligne Fixsystem est réalisée en tôle zinguée et les lignes Block et Block autoportante sont en tubulaire protégé contre la corrosion.*

*Conçues et construites pour offrir plusieurs solutions d'installation, les structures Fixsystem, Block et Block autoportante assurent fiabilité et simplicité de montage.*

# STRUTTURE FIXSYSTEM

## FIXSYSTEM METAL MOUNTING FRAMES

### STRUCTURES FIXSYSTEM

#### Bidet Fixsystem S80

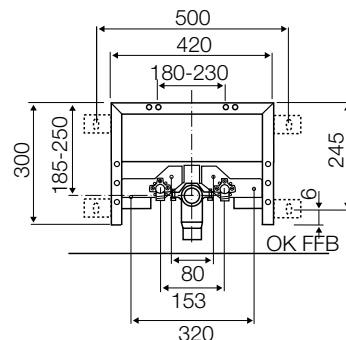
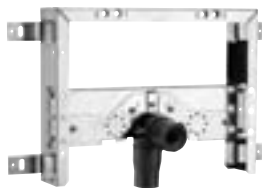

COD.	Raccordi Fittings - Raccords	S	Ø curva Ø bend - Ø coude	Materiale fissaggio Fixing material Matériel de fixation	
VS0825302	no	80	56/50	si - yes - oui	1

	Pz - Pcs	HxLxP	kg	m <sup>3</sup>
	1	110x440x340	4	0,002

	Pz - Pcs	HxLxP	kg	m <sup>3</sup>
	60	1055x800x1200	240	1,01

#### Lavabo Fixsystem S80

Fixsystem washbasin frame S80  
Lavabo Fixsystem S80

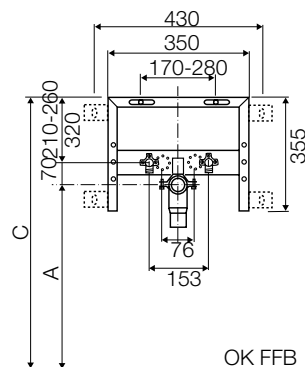

COD.	Raccordi Fittings - Raccords	S	Ø curva Ø bend - Ø coude	Materiale fissaggio Fixing material Matériel de fixation	
VS0825402	no	80	56/50	si - yes - oui	1

	Pz - Pcs	HxLxP	kg	m <sup>3</sup>
	1	110x440x340	3,5	0,002

	Pz - Pcs	HxLxP	kg	m <sup>3</sup>
	60	1055x800x1200	210	1,01

# STRUTTURE BLOCK

## BLOCK MOUNTING FRAMES

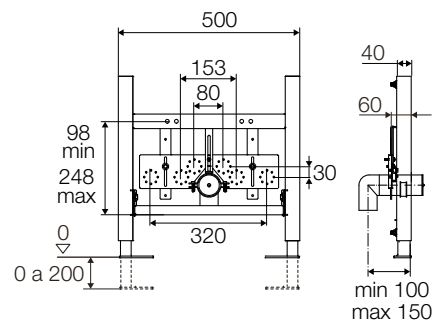
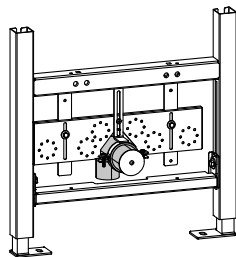

### STRUCTURES BLOCK

#### Bidet Block H 350



COD.	Raccordi - Fittings - Raccords	SxLxH	
 VS0857008	no	60x500x350	1

Piastra di supporto regolabile. - Adjustable support plate. - Plaque de support réglable.

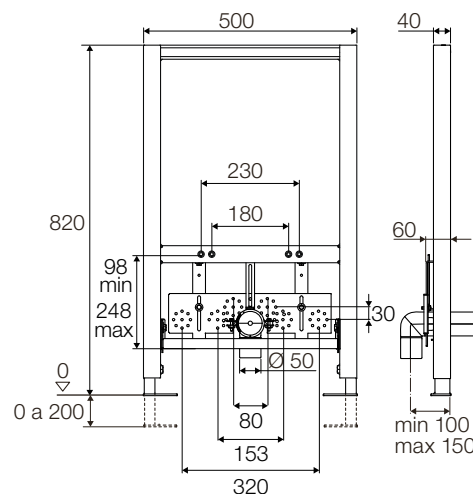
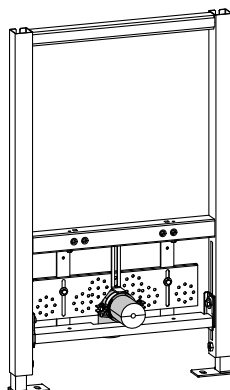

 Pz - Pcs	HxLxP	kg	m <sup>3</sup>	 Pz - Pcs	HxLxP	kg	m <sup>3</sup>
1	590x520x135	7,2	0,05	30	2100x850x1200	224	2,14

#### Bidet Block H 820





COD.	Raccordi - Fittings - Raccords	SxLxH	
 VS0857006	no	60x500x820	1

Piastra di supporto regolabile. - Adjustable support plate. - Plaque de support réglable.

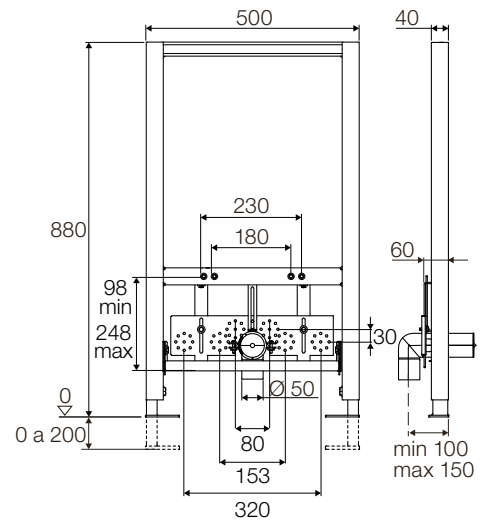
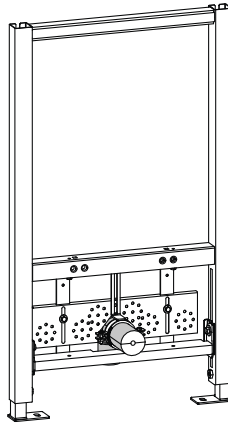

 Pz - Pcs	HxLxP	kg	m <sup>3</sup>	 Pz - Pcs	HxLxP	kg	m <sup>3</sup>
1	900x520x90	9,8	0,04	30	2100x850x1200	302	2,14

## Bidet Block H 880



COD.	Raccordi - Fittings - Raccords	SxLxH	
 VS0857004	no	60x500x880	1

Piastra di supporto regolabile. - Adjustable support plate. - Plaque de support réglable.

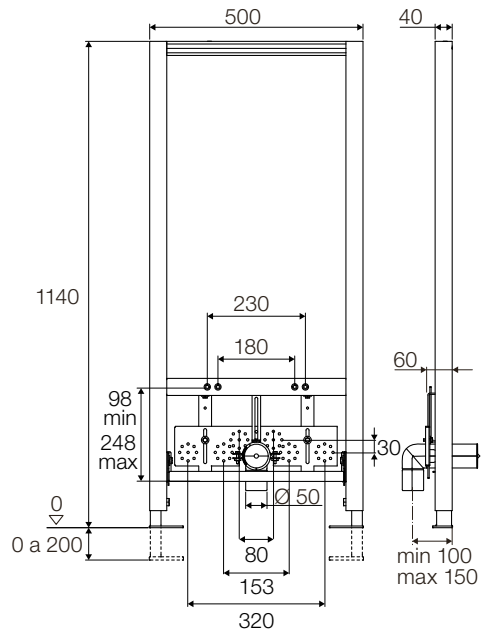
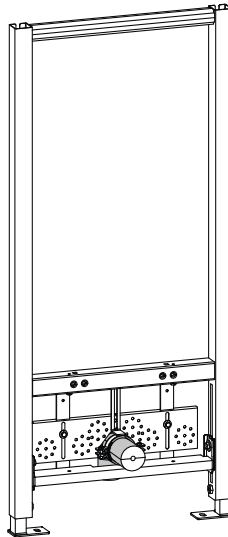

 Pz - Pcs	HxLxP	kg	m <sup>3</sup>	 Pz - Pcs	HxLxP	kg	m <sup>3</sup>
1	900x520x90	10,3	0,04	30	2400x800x1200	317	1,87

## Bidet Block H 1140



COD.	Raccordi - Fittings - Raccords	SxLxH	
 VS0857002	no	60x500x1140	1

Piastra di supporto regolabile. - Adjustable support plate. - Plaque de support réglable.



 Pz - Pcs	HxLxP	kg	m <sup>3</sup>	 Pz - Pcs	HxLxP	kg	m <sup>3</sup>
1	1170x520x90	11	0,05	30	2400x800x1200	330	1,77

## Lavabo Block H 820

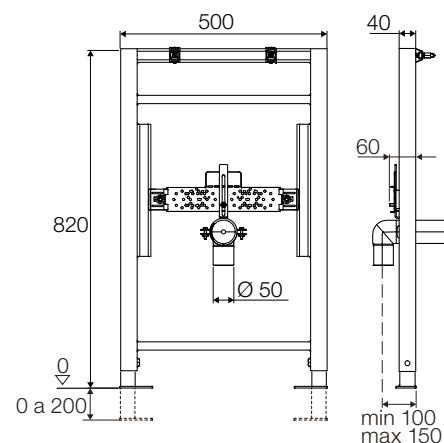
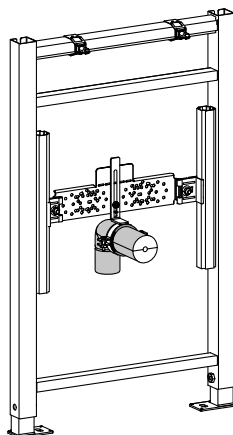
Block washbasin frame H 820  
Lavabo Block H 820



COD.	Rubinetto - Tap - Robinet	SxLxH	
 VS0857016	monoforo - single spray - simple trou	60x500x820	1



 Pz - Pcs	HxLxP	kg	m <sup>3</sup>	 Pz - Pcs	HxLxP	kg	m <sup>3</sup>
1	900x520x90	9	0,04	30	2400x850x1200	278	2,45

## Lavabo Block H 880

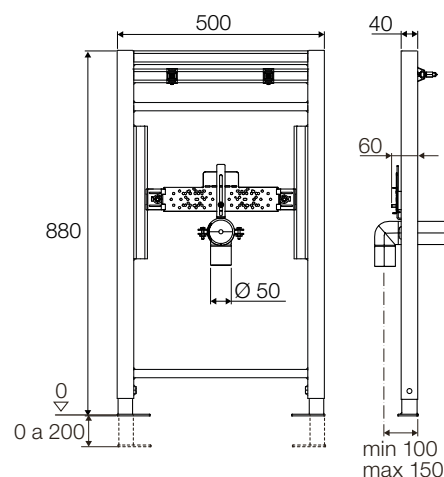
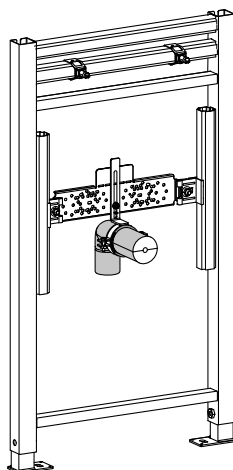
Block washbasin frame H 880  
Lavabo Block H 880



COD.	Rubinetto - Tap - Robinet	SxLxH	
 VS0857014	monoforo - single spray - simple trou	60x500x880	1

 Pz - Pcs	HxLxP	kg	m <sup>3</sup>	 Pz - Pcs	HxLxP	kg	m <sup>3</sup>
1	900x520x90	9,8	0,04	30	2400x850x1200	302	2,45

**Lavabo Block H 1140  
rubinetto monoforo**

Block washbasin frame H 1140  
single spray tap

Lavabo Block H 1140  
- mural robinet

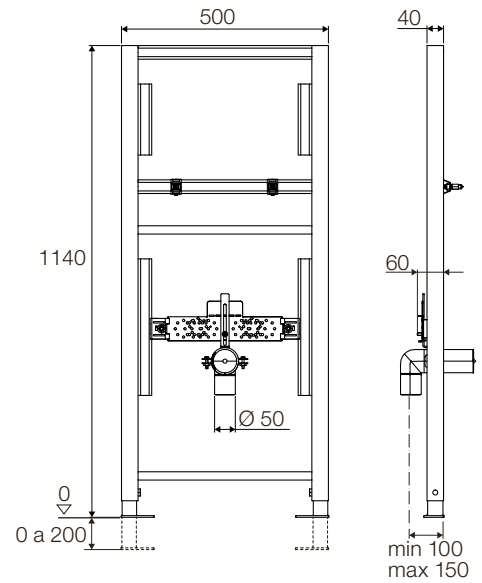
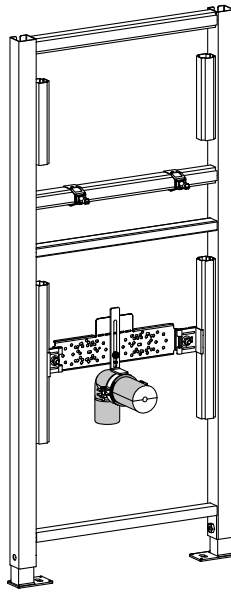

COD.	Rubinetto - Tap - Robinet	SxLxH	
VS0857012	monoforo - single spray - simple trou	60x500x1140	1

	Pz - Pcs	HxLxP	kg	m <sup>3</sup>
	1	1170x520x90	11,6	0,05

	Pz - Pcs	HxLxP	kg	m <sup>3</sup>
	30	2400x800x1200	356	2,3

**Lavabo Block H 1140  
rubinetto a parete**

Block washbasin frame H 1140  
wall tap

Lavabo Block H 1140  
- mural robinet

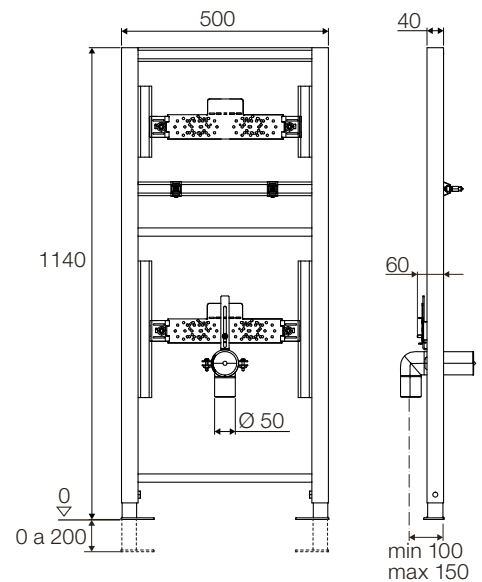
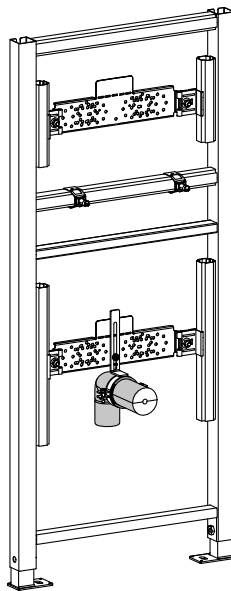

COD.	Rubinetto - Tap - Robinet	SxLxH	
VS0857013	a parete - wall - mural	60x500x1140	1

	Pz - Pcs	HxLxP	kg	m <sup>3</sup>
	1	1170x520x90	11,6	0,05

	Pz - Pcs	HxLxP	kg	m <sup>3</sup>
	30	2400x800x1200	356	2,3

## Orinatoio Block H 1140

Block urinal frame H 1140  
Orinatoio Block H 1140

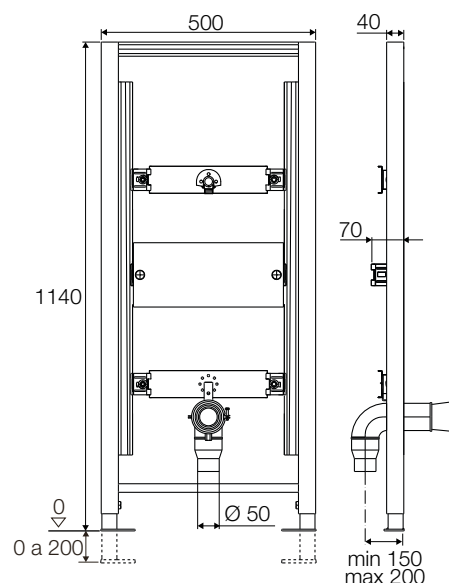
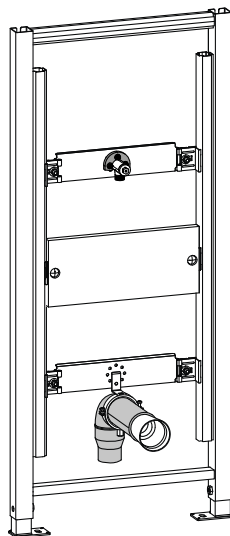

COD.	Raccordi - Fittings - Raccords	SxLxH	
VS0857022	½" F	70x500x1140	1

Pz - Pcs	HxLxP	kg	m³	Pz - Pcs	HxLxP	kg	m³
1	1170x520x90	12,5	0,08	30	2400x800x1200	375	2,3

## Infrarossa Blick

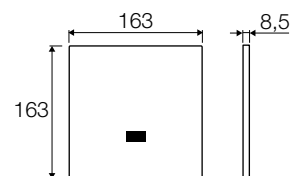

COD.	Alimentazione - Power supply - Alimentation	Colore - Colour - Couleur	
VS0868951	220 V	cromo lucido - polished chrome - chrome brillant	1
VS0868953	batteria - battery - batterie	cromo lucido - polished chrome - chrome brillant	1

\* Il codice VS0868732 è necessario per l'installazione di Blick con la struttura VS0867621. - The code VS0868732 is required for installation to Blick with frame VS0867621. - La référence VS0868732 est nécessaire pour l'installation de Blick avec la structure VS0867621

Pz - Pcs	HxLxP	kg	m³
1	75x346x205	1,5	0,0053

## Accessori - Accessories - Accessoires

### Sistema fissaggio scatola comando elettronico

System for securing electronic control box

Système de fixation boîtier de commande électronique

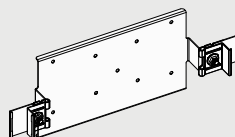

Mod. 2016

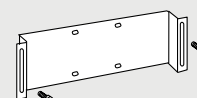



Mod. fino al - until - jusqu'à 2015

COD.	Mod.	
VS0881153	2016	1
VS0868732	fino al - until - jusqu'à 2015	1

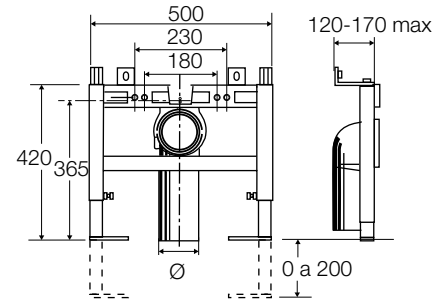
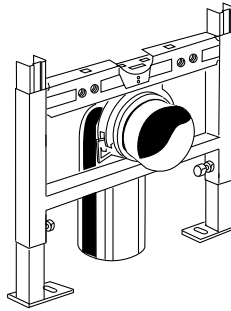

## WC Block H 420



COD.	SxLxH	Ø curva Ø bend - Ø coude	
VS0867032	150x500x420	110	1
VS0867034	150x500x420	100 PVC	1



Pz - Pcs	HxLxP	kg	m <sup>3</sup>
<b>VS0867032</b>	1	530x600x160	7,5 0,051
<b>VS0867034</b>	1	530x600x160	8,5 0,051





Pz - Pcs	HxLxP	kg	m <sup>3</sup>
30	2100x850x1200	233	2,14
27	2100x800x1200	230	2,01

## Struttura Block per maniglione disabili e separatori orinatoio H 1140

Block frame for handrails for the disabled and urinal screens H 1140

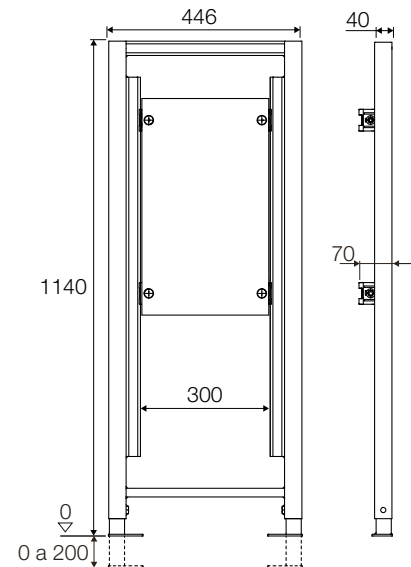
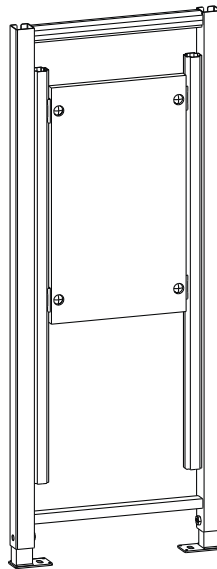
Structure Block pour poignée d'appui pour personnes handicapées et séparateurs d'urinoir H 1140



COD.	SxLxH	
 VS0857032	70x446x1140	1



Pz - Pcs	HxLxP	kg	m <sup>3</sup>
1	1170x520x90	11,5	0,05



Pz - Pcs	HxLxP	kg	m <sup>3</sup>
30	2400x800x1200	345	2,3

# STRUTTURE BLOCK AUTOPORTANTI

FREE-STANDING BLOCK FRAMES

STRUCTURES BLOCK AUTOPORTANT

## Bidet Block autoportante H 350

Bidet Block free-standing H 350

Bidet Block autoportant H 350

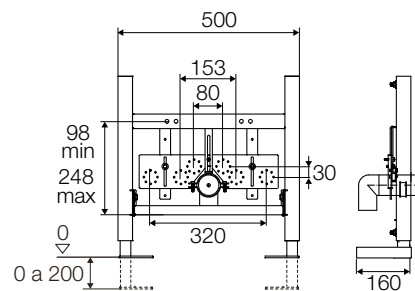
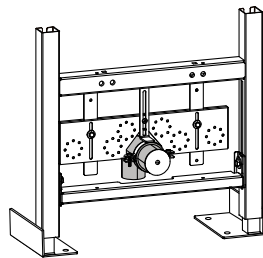

**COD.**

**SxLxH**



VS0857058

160x500x350

1



**Pz - Pcs**

**HxLxP**

**kg m<sup>3</sup>**



**Pz - Pcs**

**HxLxP**

**kg m<sup>3</sup>**

1

590x520x135

7,2 0,05

30

2100x800x1200

324 2

## Bidet Block autoportante H 820

Block frame bidet free-standing H 820

Bidet Block autoportant H 820

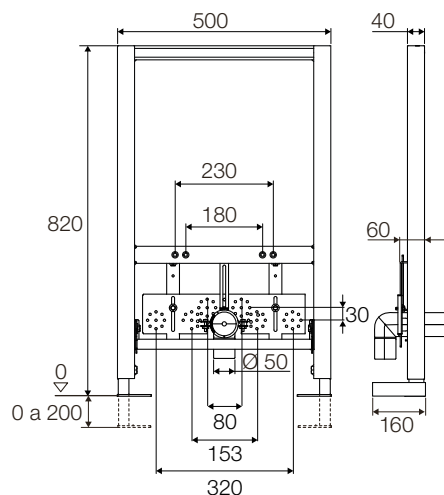
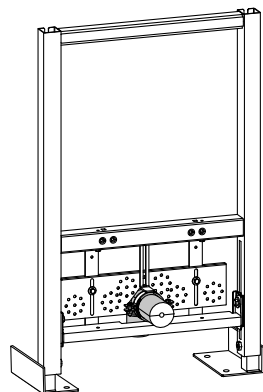

**COD.**

**SxLxH**



VS0857056

160x500x820

1



**Pz - Pcs**

**HxLxP**

**kg m<sup>3</sup>**



**Pz - Pcs**

**HxLxP**

**kg m<sup>3</sup>**

1

900x520x90

9,8 0,04

30

2100x800x1200

302 2

## Lavabo Block autoportante H 820

Block free-standing  
washbasin frame H 820

Lavabo Block autoportant H 820

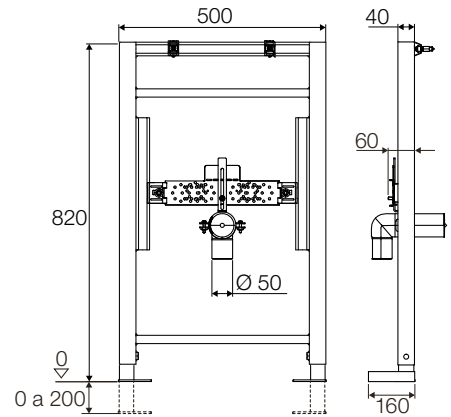
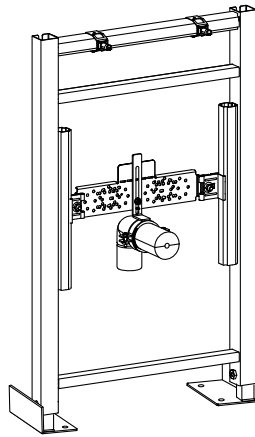

COD.	Rubinetto - Tap - Robinet	SxLxH	
 VS0857066	monoforo - single spray - simple trou	160x500x820	1

 Pz - Pcs	HxLxP	kg	m <sup>3</sup>
1	900x520x90	9	0,04

 Pz - Pcs	HxLxP	kg	m <sup>3</sup>
30	2400x850x1200	278	2,4

## WC Block autoportante H 400

WC Block free-standing h 400

WC Block fixation  
autoportant H 400

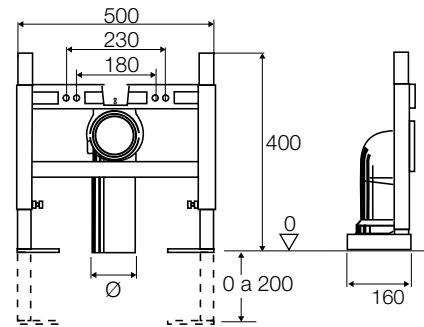
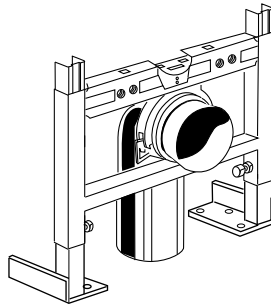

COD.	SxLxH	Ø curva - Ø bend - Ø coude	
VS0867132	160x500x400	110	1
VS0867134	160x500x400	100 PVC	1

 Pz - Pcs	HxLxP	kg	m <sup>3</sup>
<b>VS0867132</b>	1	580x520x145	12 0,044
<b>VS0867134</b>	1	530x600x160	11,5 0,051

 Pz - Pcs	HxLxP	kg	m <sup>3</sup>
24	2100x800x1200	288	2,01
27	2100x800x1200	311	2,01

# ACCESSORI CASSETTE E STRUTTURE

ACCESSORIES FOR CISTERNS AND FRAMES

ACCESSOIRES POUR RÉSERVOIR ET STRUCTURES

## Curva WC per vaso sospeso completa di guarnizione e tappo di protezione

WC toilet bend for wall-hung pan with seal and protective cap

Pipe de WC pour cuvette suspendue avec joint et bouchon de protection

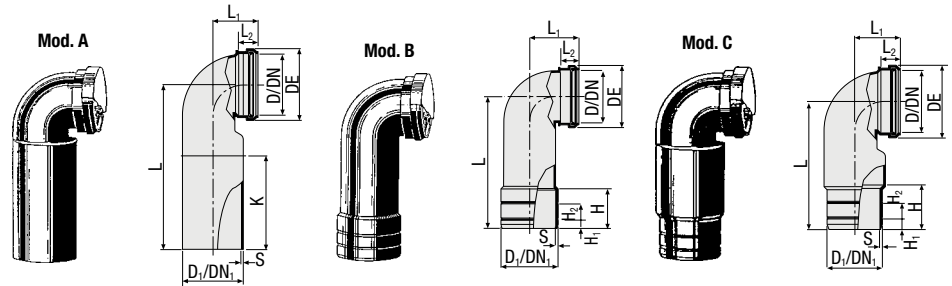

COD.	D/D <sub>1</sub>	DN/DN <sub>1</sub>	Mod.	Mat.	s	L	L <sub>1</sub>	L <sub>2</sub>	DE	H	H <sub>1</sub>	H <sub>2</sub>	K	kg				HxLxP
VS0364001	90/90	90/90	A	HDPE	3,5	270	90	40	108	-	-	-	150	0,398	10	40	160	1050x800x1200
VS0364003	110/110	100/100	A	HDPE	4,3	300	87	40	130	-	-	-	180	0,596	10	40	160	1210x800x1200
VS0364006 *	90/90	90/90	A	PP	3,5	230	65	35	108	-	-	-	150	0,398	10	40	160	1210x800x1200
VS0364008 *◆	90/90	90/90	A	PP	2,5	400	66	33	105	-	-	-	-	0,35	10	40	160	1210x800x1200
VS0364015	90/100	90/100	A	PVC	3,6	300	90	35	108	-	-	-	-	0,622	1	-	-	980x800x1200
VS0364052	90/100	90/100	A	PP	2,9	230	86	32	108	-	-	-	136	0,271	1	-	168	980x800x1200
VS0364059	90/100	90/100	B	HDPE	3,7	230	86	52	109	69	18	25	-	0,357	1	-	-	-
VS0364111	90/110	90/100	A	HDPE	4,3	230	90	40	108	74	24	15	-	0,360	10	40	160	1050x800x1200
VS0364090	90/100	90/100	B	HDPE	4,9	230	87	40	130	76	25	25	-	0,526	10	40	160	1050x800x1200
VS0364100 ◆	110/100	100/100	C	HDPE	-	-	-	-	-	-	-	-	-	-	10	40	160	1210x800x1200

\* Non ingombro. - Space-saving. - Faible encombrement.

◆ Derivazione saldata. - Welded. - Dérivation soudée.

## Curva WC sospeso doppia orizzontale, completa di guarnizioni e tappi di protezione

Double bend for wall-hung WC toilet, horizontal installation, with seals and protective caps

Pipe de WC horizontale double parallèle avec joints et bouchons de protection

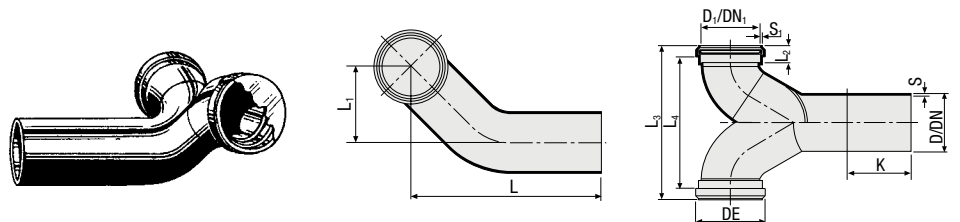

COD.	D/D <sub>1</sub>	DN/DN <sub>1</sub>	s	s <sub>1</sub>	DE	L	L <sub>1</sub>	L <sub>2</sub>	L <sub>3</sub>	L <sub>4</sub>	K	kg				HxLxP
VS0374001	110/110	100/100	4,3	4,3	130	340	95	37	285	240	120	1,090	5	20	40	950x800x1200
VS0374003	110/90	100/90	4,3	3,5	108	335	100	-	270	-	120	1,020	5	20	40	950x800x1200

Derivazione saldata. - Welded. - Dérivation soudée.

**Curva WC sospeso  
doppia verticale,  
completa di guarnizioni  
e tappi di protezione**

*Double bend for wall-hung  
WC toilet, vertical installation*

*Pipe de WC double parallèle  
pour cuvette suspendue avec  
joint et bouchon de protection*

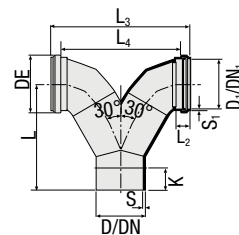
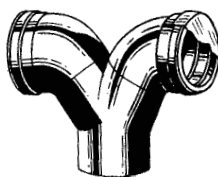

COD.	D/D <sub>1</sub>	DN/DN <sub>1</sub>	s	s <sub>1</sub>	DE	L	L <sub>2</sub>	L <sub>3</sub>	L <sub>4</sub>	K	kg				HxLxP
VS0368001	110/110	100/100	4,3	4,3	130	205	37	285	240	50	0,816	5	20	60	1054x800x1200
VS0368003	110/90	100/90	4,3	3,5	108	210	-	270	-	50	0,764	5	20	60	1054x800x1200

Derivazione saldata. - *Welded.* - *Dérivation soudée.*

**Curva WC sospeso  
orizzontale sinistra,  
completa di  
guarnizione e tappo  
di protezione**

*Bend for wall-hung WC  
toilet, horizontal installation,  
left, with seal and cap*

*Pipe de WC horizontale gauche  
pour cuvette suspendue avec  
joint et bouchon de protection*

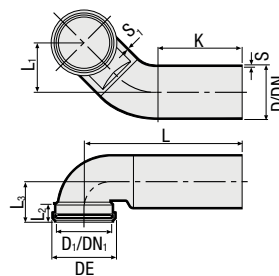
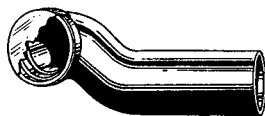

COD.	D/D <sub>1</sub>	DN/DN <sub>1</sub>	s	s <sub>1</sub>	DE	L	L <sub>1</sub>	L <sub>2</sub>	L <sub>3</sub>	K	kg				HxLxP
VS0370002	90/90	90/90	3,5	3,5	108	290	100	35	85	150	0,442	5	40	120	1015x800x1200
VS0370003	110/90	100/90	4,3	3,5	108	315	100	35	85	170	0,616	5	20	80	1050x800x1200
VS0370001	110/110	100/100	4,3	4,3	130	320	100	35	85	170	0,720	5	20	80	1050x800x1200

Derivazione saldata. - *Welded.* - *Dérivation soudée.*

## Curva WC sospeso orizzontale destra, completa di guarnizione e tappo di protezione

*Bend for wall-hung WC  
toilet, horizontal installation,  
right, with seal and cap*

*Pipe de WC horizontale droite  
pour cuvette suspendue avec  
joint et bouchon de protection*

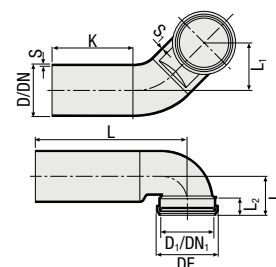

COD.	D/D <sub>1</sub>	DN/DN <sub>1</sub>	s	s <sub>1</sub>	DE	L	L <sub>1</sub>	L <sub>2</sub>	L <sub>3</sub>	K	kg				HxLxP
VS0372002	90/90	90/90	3,5	3,5	110	290	100	35	85	150	0,442	5	40	120	1015x800x1200
VS0372003	110/90	100/90	4,3	3,5	108	315	100	35	85	170	0,616	5	20	80	1050x800x1200
VS0372001	110/110	100/100	3,5	4,3	130	340	100	35	85	170	0,720	5	20	80	1050x800x1200

Derivazione saldata. - *Welded.* - *Dérivation soudée.*

## Raccordo dritto per vaso sospeso completo di guarnizione e tappo di protezione

*Straight connector for wall-hung  
pan with seal and protective cap*

*Sortie droite pour cuvette  
suspendue avec joint et  
bouchon de protection*

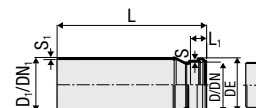
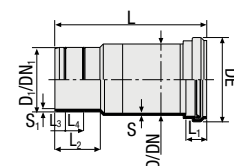
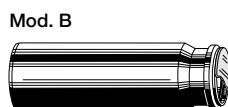
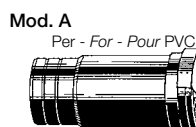

COD.	D/D <sub>1</sub>	DN/DN <sub>1</sub>	Mod.	S	S <sub>1</sub>	DE	L	L <sub>1</sub>	L <sub>2</sub>	L <sub>3</sub>	L <sub>4</sub>	kg				HxLxP
VS0366090	90/100	90/100	A	3,5	5,5	109	232	31	70	15	28	0,332	10	80	240	1015x800x1200
VS0366113	90/110	90/100	B	4,3	4,30	109	300	31	180	-	-	0,480	10	40	160	1050x800x1200

Derivazione saldata. - *Welded.* - *Dérivation soudée.*

## Manicotto lungo per vaso sospeso completo di guarnizione

*Long connection sleeve for  
wall-hung pan with seal*

*Manchon long de  
raccordement pour cuvette  
suspendue avec joint*

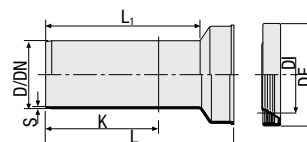
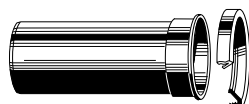

COD.	D	DN	s	DI	DE	L	L <sub>1</sub>	K	kg				HxLxP
VS0366125 *	90	90	3,5	140	102±5	250	200	150	0,360	10	40	160	1050x800x1200
VS0366133	90	90	3,5	140	102±5	300	260	200	0,420	10	40	160	1050x800x1200

\* Derivazione saldata. - *Welded.* - *Dérivation soudée.*

## Manicotto di allacciamento per WC sospeso

Connection sleeve for wall-hung WC toilet

Manchon de raccordement pour cuvette suspendue

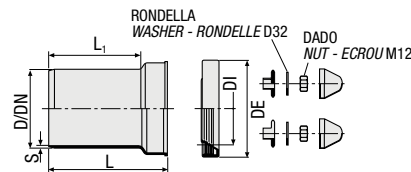
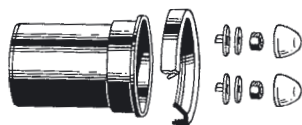

COD.	D	DN	s	DI	DE	L	L <sub>1</sub>	kg				HxLxP
VS0367001	90	90	3,5	102±5	133	166	128	0,380	10	80	240	1015x800x1200
VS0367003	110	100	4,3	102±5	131	166	128	0,440	10	80	240	1050x800x1200

## Manicotto di allacciamento per WC sospeso con guarnizione Ø 125

Sleeve for wall-hung pan with seal Ø 125

Manchon pour WC suspendu avec joint Ø 125



COD.	Ø	Mat.	kg	
VS0366002	90	HDPE	0,279	10

## Kit di allacciamento per WC sospeso

Connection kit for wall-hung WC toilet

Kit de raccordement pour cuvette suspendue

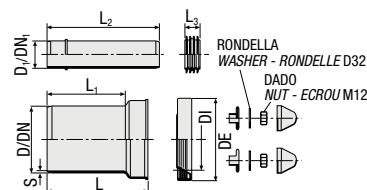
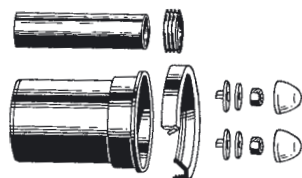

COD.	D/D <sub>1</sub>	DN	s	DI	DE	L	L <sub>1</sub>	L <sub>2</sub>	L <sub>3</sub>	kg				HxLxP
VS0366001	90/45	90	3,5	102±5	132	166	122	195	24	0,450	10	80	240	1015x800x1200
VS0366003	110/45	100	4,3	102±5	132	166	129	199	24	0,530	10	40	160	1050x800x1200

## Manicotto WC con o-ring per il collegamento al PVC

WC toilet connector for PVC with ring seal

Manchon WC avec joint torique pour le raccordement au PVC

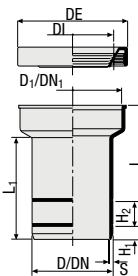
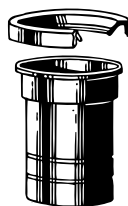

COD.	D	DN	s	DI	DE	L	L <sub>1</sub>	L <sub>2</sub>	H <sub>2</sub>	kg				HxLxP
VS0354001	100	100	4,3	102±5	140	166	125	17	30	0,350	10	80	240	1015x800x1200

Derivazione saldata. - Welded. - Dérivation soudée.

## Kit di prolungamento per cassetta scarico a due quantità, pareti di grande spessore

*Extension kit for thick walls, suitable for dual flush cisterns*

*Kit de rallonge pour réservoir de chasse à deux quantités d'évacuation, cloisons de grande épaisseur*

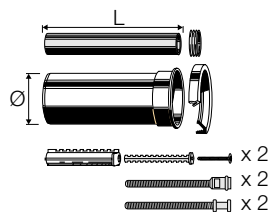

COD.	Ø	L	kg	
VS0366139	90	300	0,693	1
VS0366149	110	300	1,035	1

## Tronchetto per il collegamento al PVC ad incollaggio

*Solvent weld adaptor for connection to PVC*

*Raccord de liaison en PVC à coller*

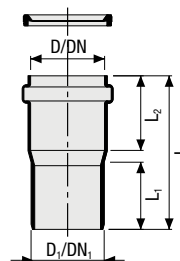
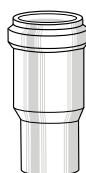

COD.	D/D <sub>1</sub>	DN/DN <sub>1</sub>	L	L <sub>1</sub>	L <sub>2</sub>	kg				HxLxP
VS0564190	90/100	90/100	143	76	65	0,250	10	80	320	1010x800x1200

## Morsetto riduzione in gomma

*Reducer rubber gasket*

*Joint en caoutchouc reduct*

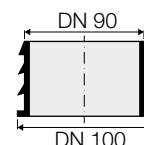
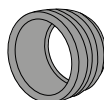

COD.	DN	
VS0587001	90/100	10

## Guarnizione eccentrica bianca per allacciamento bicchiere vaso

*White eccentric seal for WC connection*

*Joint excentrique blanc pour branchement verre vase*

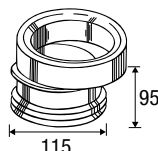

COD.	D				HxLxP
VS0700071	110/90	10	80	320	1010x800x1200



**Guarnizione  
concentrica bianca  
per allacciamento  
bicchiere vaso**

*White concentric seal  
for WC connection*

*Joint concentrique blanc pour  
branchement verre vase*

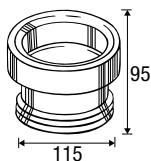

<b>COD.</b>	<b>D</b>				<b>HxLxP</b> 
VS0700073	110/90	10	80	320	1010x800x1200

**Guarnizione di prolunga  
nera per allacciamento  
bicchiere vaso**

*Black extension seal  
for WC connection*

*Joint de rallonge noir pour  
branchement verre vase*

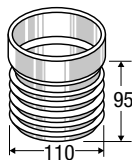

<b>COD.</b>	<b>D</b>				<b>HxLxP</b> 
VS0700075	110/90	15	120	480	1010x800x1200

**Protezione acustica per  
vaso e bidet sospeso**

*Acoustic insulation for wall-  
hung pan and bidet*

*Protection acoustique pour  
cuvette suspendue*

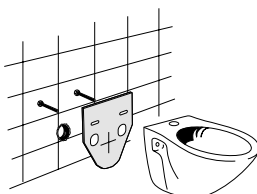

<b>COD.</b>	
VS0805350	1

**Protezione acustica  
per lavabo sospeso**

*Acoustic insulation for  
wall-hung washbasin*

*Protection acoustique  
pour lavabo suspendu*

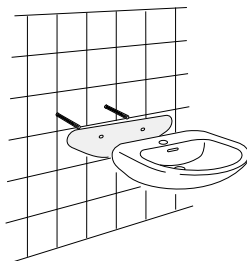

<b>COD.</b>	
VS0805355	1

## Piastra di rinforzo per cartongesso

*Reinforcement plate for plasterboard*

*Plaque de renfort pour plaques de plâtre*

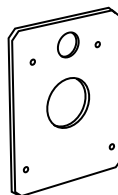

**COD.**

VS0868172



1

## Raccordo diritto flangiato per strutture idrosanitarie, completo di guarnizione antivibrante

*Straight flanged elbow with anti-vibration seal*

*Raccord droit avec écrou de serrage pour structure sanitaire avec joint isolant*

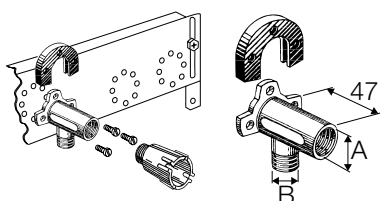

**COD.**

VS0825028

**A**

G3/8" F

**B**

G3/8" M



10



VS0825023

G1/2" F

G1/2" M

10

## Tappo filettato per protezione e prova impianto idrico

*Threaded plug for protection and plumbing system testing*

*Bouchon fileté pour la protection*

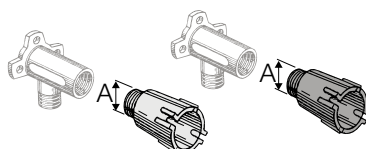

**COD.**

VS0825051

**A**

G1/2" M

**Colore - Colour - Couleur**

blu - blue - bleu



10

VS0825053

G1/2" M

rosso - red - rouge

10

VS0825056

G3/8" M

blu - blue - bleu

10

VS0825058

G3/8" M

rosso - red - rouge

10

### Kit squadrette Tropea S attacco frontale

Front bracket for Tropea S

Équerres de fixation  
pour Tropea S

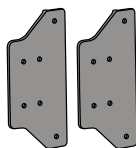

**COD.**



**NEW** VS0866704

1

### Kit squadrette Tropea S a murare

In-wall bracket for Tropea S

Équerres de fixation pour  
Tropea S au mur

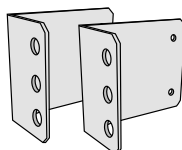

**COD.**



**NEW** VS0868239

1 (2 pz)

### Kit squadrette e distanziatori Winner S

Kit brackets and  
spacers Winner S

Kit d'éléments angulaires  
et entretoises Winner S

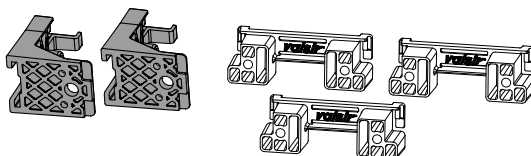

**COD.**



**NEW** VS0863860

1

### Kit squadrette Cubik S

Bracket for Cubik S

Équerres de fixation  
pour Cubik S

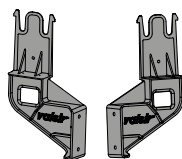

**COD.**



**NEW** VS0863861

1

# ACCESSORI FIXSYSTEM E BLOCK

## ACCESSORIES FIXSYSTEM AND BLOCK FRAMES

### ACCESSOIRES FIXSYSTEM ET BLOCK

#### Supporto frontale per strutture Fixsystem con cassetta

Frontal support for Fixsystem framed flush cisterns

Support frontal pour structures Fixsystem avec réservoir de chasse

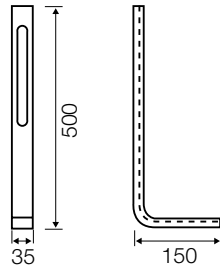

**COD.**



VS0805150

1

Set supporto zincato per il fissaggio a pavimento "tipo frontale" delle strutture Fixsystem con cassetta. - Galvanized steel support system for frontal floor attachment of Fixsystem framed flush cisterns. - Set de support zingué pour la fixation au sol "type frontal" des structures Fixsystem à réservoir.

#### Supporto laterale per strutture Fixsystem

Lateral support for Fixsystem framed

Support latéral pour structures Fixsystem

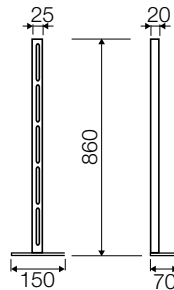

**COD.**



VS0825601

1

Set supporto zincato a piastra per il fissaggio laterale a pavimento delle strutture con cassetta, bidet e lavabo Fixsystem (2 pz). - Galvanized steel support system for lateral floor attachment of Fixsystem framed flush cisterns, bidet and washbasin (2 pcs). - Set de support zingué à plaque pour la fixation latérale au sol des structures Fixsystem à réservoir, bidet et lavabo Fixsystem (2 pièces).

#### Supporto Block per strutture Fixsystem con cassetta

Block support for Fixsystem framed flush cisterns

Support Block pour structures Fixsystem avec réservoir de chasse

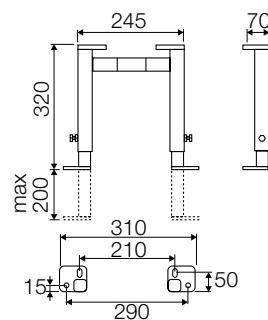

**COD.**



VS0826101

1

Supporto portante per strutture Fixsystem WC a murare, in acciaio zincato completo di viteria per il fissaggio alla struttura e al pavimento. - Galvanized steel support for Fixsystem WC frames, provided with screws for fixing material. - Support porteur pour structure Fixsystem WC au mur, en acier zingué complété d'une visserie pour la fixation à la structure et au sol.

**Kit gambe Block  
autoportante  
complete di tasselli  
di fissaggio speciali**

*Feet for free standing "Block"  
frames with fixing material*

*Kit pieds Block autoportant  
avec vis de fixation spécifiques*

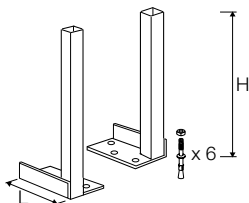

<b>COD.</b>	<b>H</b>	<b>L</b>	
VS0868625	500	160	1

Solo per - Only for - Seulement pour Winner, Cubik, Angel, Evolut Block, Tropea3 Block autoportante - free-standing - autoportant.

# **CASSETTEESTERNE**

*EXPOSED FLUSH CISTERNS*  
*RÉSERVOIRS APPARENTS*



## **UN CLASSICO SENZA TEMPO** *A TIMELESS CLASSIC* *UN CLASSIQUE INTEMPOREL*

### **CARATTERISTICHE**







- Ampia gamma di soluzioni per qualsiasi tipologia di installazione.
- Possibilità del doppio comando per la scelta dello scarico totale o parziale.
- Possibilità di pneumatizzazione.
- Tutta la gamma è munita di foderina anti-condensa.
- Possibilità di installazione a bassa, media e alta posizione.
- Possibilità di abbinamento a vaso monoblocco.
- Modello specifico per locali pubblici, caratterizzato da coperchio antibruciatore di sigaretta.
- Utilizzo di materiali plastici con additivi anti ingiallimento.
- Rumorosità limitata.
- Design innovativo.
- Approvato dai più importanti Istituti di Certificazione mondiali in accordo alle diverse normative nazionali ed internazionali.

### **CHARACTERISTICS**

- *Wide range of solutions for all types of installations.*
- *Possibility of dual flush with the choice of a full or partial flush volume.*
- *Possibility of pneumatic flush.*
- *The entire range is supplied with an anti-condensation lining.*
- *Possibility of low, medium and high position installation.*
- *Possibility of use with close-coupled pan.*
- *Specifically designed for public toilets, characterised by cigarette burn resistant lid.*
- *Use of plastic materials with anti-yellowing additives.*
- *Limited noise levels.*
- *Innovative design.*
- *Approved by the most important Certification Institutes worldwide in compliance with the various national and international standards.*

### **CARACTÉRISTIQUES**

- *Ample gamme de solutions pour toute typologie d'installation.*
- *Possibilité de double commande pour le choix d'évacuation totale ou partielle.*
- *Possibilité de conversion pneumatique.*
- *Toute la gamme est dotée d'un fourreau anticondensation.*
- *Possibilité d'installation en position basse, moyenne et haute.*
- *Possibilité d'association à un w.c. monobloc.*
- *Modèle spécifique pour locaux publics, caractérisé par un couvercle antibrûlure de cigarette.*
- *Utilisation de matières plastiques avec des additifs anti-jaunissement.*
- *Bruit limité.*
- *Design novateur.*
- *Approuvé par les plus importants organismes de certification mondiaux en accord avec les différentes normes nationales et internationales.*

Mod.	Tipologia installazione <i>Installation type</i> <i>Typologie installation</i>			Volume scarico <i>Flush volume</i> <i>Volume chasse d'eau</i>			Versione pneumatica <i>Pneumatic version</i> <i>Version pneumatique</i>
							 PNEU
CORALLO3		•		•			•
PERK		•				•	
MIDA		•				•	•
MUREX			•		•		•
ALTANTA	•	•		•		•	+ KIT PNEU
SOLEA	•	•				•	+ KIT PNEU
ISLAND		•		•			+ KIT PNEU

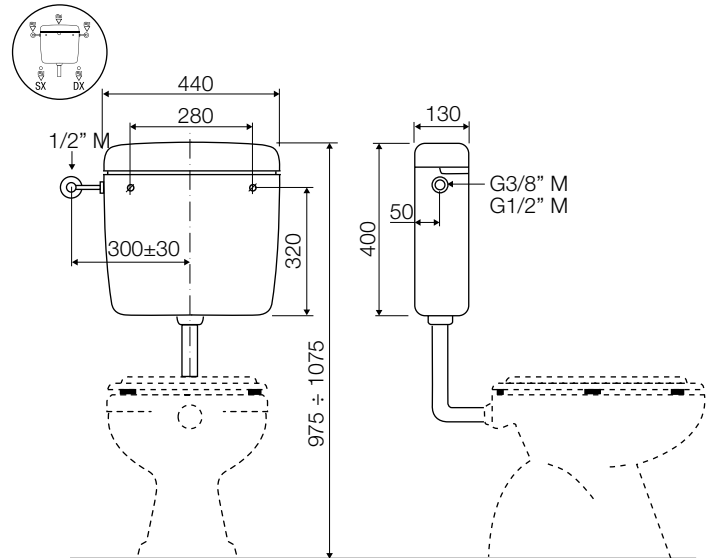

- **Tipologia installazione:** bassa posizione
- **Volume scarico:** 6/3 l (pre-regolato), 9/3 l
- **Vano alloggio detergente:** si
- **Materiale fissaggio:** incluso
- **Colore:** bianco
- **Kit tubi pneumatico remoto:** non incluso

- **Installation type:** low position
- **Flush volume:** 6/3 l (standard setting), 9/3 l
- **Receptacle for sanitizing tablet:** yes
- **Fixing material:** included
- **Colour:** white
- **Pneumatic hoses kit for remote installation:** not included

- **Typologie installation :** basse position
- **Volume chasse d'eau :** 6/3 (pré-réglé), 9/3 l
- **Compartment détergent :** oui
- **Matériel de fixation :** inclus
- **Couleur :** blanc
- **Kit tuyaux pneumatique à distance :** non inclus

## Meccanica - Mechanic - Mécanique

COD.	Scarico Flush Évacuation	Tubo Flush pipe Tube	Rub. galleggiante Float valve Rob. flotteur	Rub. d'arresto incluso Stop valve included Robinet d'arrêt inclus	
VS0816101	doppio dual - double	si - yes - oui	3/8"	si - yes - oui 1/2"	5
VS0816103	doppio dual - double	no	3/8"	no	5
VS0816105	doppio dual - double	si - yes - oui	1/2"	no	5

## Pneumatica - Pneumatic - Pneumatique

COD.	Scarico Flush Évacuation	Tubo Flush pipe Tube	Rub. galleggiante Float valve Rob. flotteur	Rub. d'arresto incluso Stop valve included Robinet d'arrêt inclus	
VS0816151	singolo single - simple	no	3/8"	no	5
VS0816153	doppio dual - double	no	3/8"	no	5

	Pz - Pcs	HxLxP	kg	m <sup>3</sup>
1	500x478x150	3,9	0,036	

	Pz - Pcs	HxLxP	kg	m <sup>3</sup>
5	520x800x485	19,5	0,21	

	Pz - Pcs	HxLxP	kg	m <sup>3</sup>
60	2230x800x1600	242	2,85	



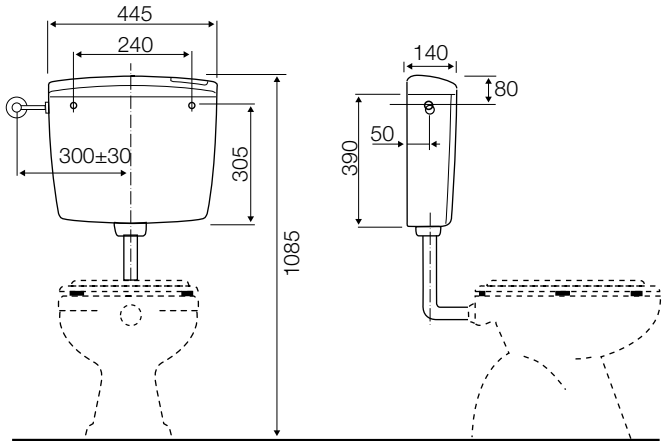



- **Tipologia installazione:** bassa posizione
- **Volume scarico:** 6 l
- **Materiale fissaggio:** incluso
- **Colore:** bianco

- **Installation type:** low position
- **Flush volume:** 6 l
- **Fixing material:** included
- **Colour:** white

- **Typologie installation :** basse position
- **Volume chasse d'eau :** 6 l
- **Matériel de fixation :** inclus
- **Couleur :** blanc

COD.	Scarico Flush Évacuation	Tubo Flush pipe Tube	Rubinetto d'arresto Stop valve Robinet d'arrêt	Attacco Water inlet Alimentation	
VS0846001	6 l + STOP	si - yes - oui	-	alto - high - haut 3/8"	1
VS0846101	6 l + STOP	si - yes - oui	-	alto - high - haut 1/2"	1
VS0847001	6 l + STOP	si - yes - oui	1/2"	alto - high - haut	1

	Pz - Pcs	HxLxP	kg	m <sup>3</sup>
1	1	470x450x150	2,63	0,032

	Pz - Pcs	HxLxP	kg	m <sup>3</sup>
65	65	2390x800x1200	180	2,30

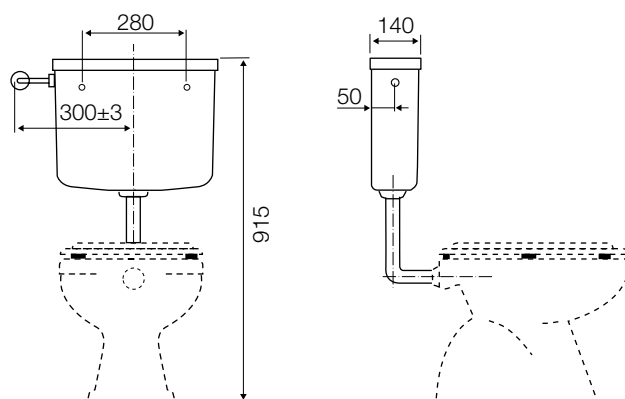

- **Tipologia installazione:** bassa posizione
- **Volume scarico:** 6 (pre-regolato), 9 l
- **Materiale fissaggio:** incluso
- **Colore:** bianco
- **Kit tubi pneumatico remoto:** non incluso

- **Installation type:** low position
- **Flush volume:** 6 (standard setting), 9 l
- **Fixing material:** included
- **Colour:** white
- **Pneumatic hoses kit for remote installation:** not included

- **Typologie installation :** basse position
- **Volume chasse d'eau :** 6 (pré-réglé), 9 l
- **Matériel de fixation :** inclus
- **Couleur :** blanc
- **Kit tuyaux pneumatique à distance :** non inclus

### Meccanica - Mechanic - Mécanique

COD.	Scarico Flush Évacuation	Tubo Flush pipe Tube	Rubinetto d'arresto Stop valve Robinet d'arrêt	Attacco Water inlet Alimentation	
VS0840901	6 l + STOP	si - yes	1/2"	alto - high - haut	5
VS0844001	6 l + STOP	si - yes	-	alto - high - haut 3/8"	5

### Pneumatica - Pneumatic - Pneumatique

COD.	Scarico Flush Évacuation	Tubo Flush pipe Tube	Rubinetto d'arresto Stop valve Robinet d'arrêt	Attacco Water inlet Alimentation	
VS0842901	6 l	no	-	alto - high - haut 3/8"	5

	Pz - Pcs	HxLxP	kg	m <sup>3</sup>
	1	500x478x150	3,4	0,036

	Pz - Pcs	HxLxP	kg	m <sup>3</sup>
	5	520x800x485	17	0,21

	Pz - Pcs	HxLxP	kg	m <sup>3</sup>
	60	2230x800x1600	242	2,85

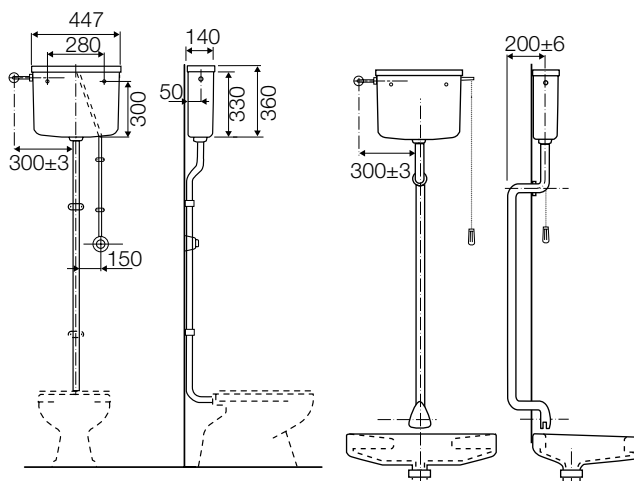



- **Tipologia installazione:** alta posizione
- **Volume scarico:** 6 (pre-regolato), 9 l
- **Materiale fissaggio:** incluso
- **Colore:** bianco
- **Kit tubi pneumatico remoto:** non incluso
- **Installation type:** high position
- **Flush volume:** 6 (standard setting), 9 l
- **Fixing material:** included
- **Colour:** white
- **Pneumatic hoses kit for remote installation:** not included
- **Typologie installation :** haute position
- **Volume chasse d'eau :** 6 (pré-réglé), 9 l
- **Matériel de fixation :** inclus
- **Couleur :** blanc
- **Kit tuyaux pneumatique à distance :** non inclus

## Meccanica - Mechanic - Mécanique

COD.	Scarico Flush Évacuation	Tubo Flush pipe Tube	Coperchio Lid Couvercle	Rubinetto d'arresto Stop valve Robinet d'arrêt	Attacco Water inlet Alimentation	
VS0860901	6 l	no	•	-	alto - high - haut 3/8"	5
VS0861901	6 l	no	•	1/2"	alto - high - haut	5
VS0869001	6 l	no	•	-	alto - high - haut 1/2"	5
VS0869101	6 l	no	-	-	alto - high - haut 1/2"	5

## Pneumatica - Pneumatic - Pneumatique

COD.	Scarico Flush Évacuation	Tubo Flush pipe Tube	Coperchio Lid Couvercle	Rubinetto d'arresto Stop valve Robinet d'arrêt	Attacco Water inlet Alimentation	
VS0862901	6 l	no	•	-	alto - high - haut 3/8"	5

	Pz - Pcs	HxLxP	kg	m <sup>3</sup>		Pz - Pcs	HxLxP	kg	m <sup>3</sup>		Pz - Pcs	HxLxP	kg	m <sup>3</sup>
	1	500x478x150	3,17	0,036		5	520x800x485	16	0,21		60	2230x800x1600	198	2,85

## Monoblocco

Close-coupled - Monobloc

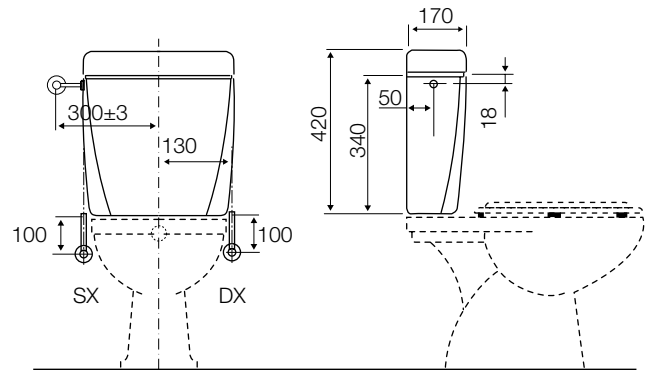

- **Tipologia installazione:** monoblocco
- **Volume scarico:** 6/3 (pre-regolato), 9/3 l
- **Materiale fissaggio:** incluso
- **Colore:** 01 bianco, 05 grigio Manhattan
- **Kit tubi pneumatico remoto:** non incluso

- **Installation type:** close-coupled
- **Flush volume:** 6/3 (standard setting), 9/3 l
- **Fixing material:** included
- **Colour:** 01 white, 05 Manhattan grey
- **Pneumatic hoses kit for remote installation:** not included

- **Typologie installation :** monobloc
- **Volume chasse d'eau :** 6/3 (pré-réglé), 9/3 l
- **Matériel de fixation :** inclus
- **Couleur :** 01 blanc, 05 gris Manhattan
- **Kit tuyaux pneumatique à distance :** non inclus

### Coperchio violabile - Violable lid - Couvercle visible

COD.	Scarico Flush Évacuation	Rubinetto d'arresto Stop valve Robinet d'arrêt	Attacco Water inlet Alimentation	
VS0830001	6 l + STOP	1/2"	alto - high - haut	5
VS0830005 •	6 l + STOP	1/2"	alto - high - haut	5
VS0832001 •	6 l + STOP	-	alto - high - haut 1/2"	5
VS0831701	6 l + STOP	-	basso - low - faible 3/8"	5
VS0830501	6/3 l	1/2"	alto - high - haut	5
VS0831901	6/3 l	-	alto - high - haut 3/8"	5
VS0831601	6/3 l	-	alto - high - haut 1/2"	5

### Coperchio inviolabile - Tamper-proof lid - Couvercle inviolable

COD.	Scarico Flush Évacuation	Rubinetto d'arresto Stop valve Robinet d'arrêt	Attacco Water inlet Alimentation	
VS0831101 •	6 l + STOP	-	alto - high - haut 3/8"	5

- Ad esaurimento. - Sell out. - Fin de stock.

	Pz - Pcs	HxLxP	kg	m <sup>3</sup>
1	1	470x424x180	3,9	0,036

	Pz - Pcs	HxLxP	kg	m <sup>3</sup>
5	5	500x927x445	19,5	0,2

	Pz - Pcs	HxLxP	kg	m <sup>3</sup>
60	60	2530x800x1200	242	2,43

## Bassa posizione

Low level installation - Position basse

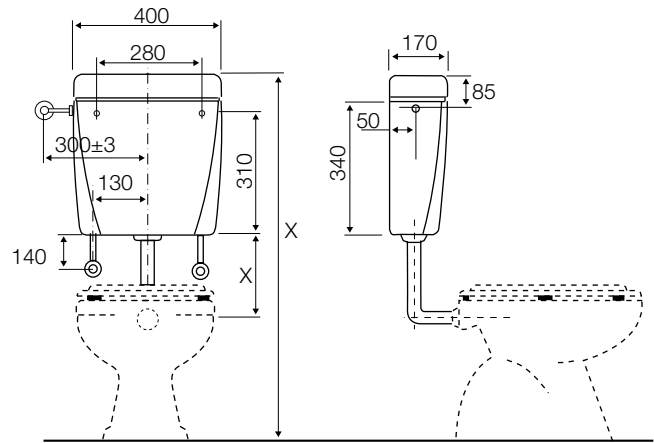

- **Tipologia installazione:** bassa posizione
- **Volume scarico:** 6/3 (pre-regolato), 9/3 l
- **Materiale fissaggio:** incluso
- **Colore:** bianco
- **Kit tubi pneumatico remoto:** non incluso

- **Installation type:** low position
- **Flush volume:** 6/3 (standard setting), 9/3 l
- **Fixing material:** included
- **Colour:** white
- **Pneumatic hoses kit for remote installation:** not included

- **Typologie installation :** basse position
- **Volume chasse d'eau :** 6/3 (pré-réglé), 9/3 l
- **Matériel de fixation :** inclus
- **Couleur :** blanc
- **Kit tuyaux pneumatique à distance :** non inclus

COD.	Scarico Flush Évacuation	Tubo Flush pipe Tube	Rubinetto d'arresto Stop valve Robinet d'arrêt	Attacco Water inlet Alimentation	
VS0835001	6 l + STOP	si - yes - oui	1/2"	alto - high - haut	5
VS0836001 •	6 l + STOP	si - yes - oui	-	alto - high - haut 3/8"	5
VS0835301	6 l + STOP	no	-	basso - low - faible 3/8"	5
VS0835901	6/3 l	si - yes - oui	1/2"	alto - high - haut	5
VS0837601	6/3 l	si - yes - oui	-	alto - high - haut 3/8"	5
VS0837501	6/3 l	si - yes - oui	-	alto - high - haut 1/2"	5

- Ad esaurimento. - Sell out. - Fin de stock.

	Pz - Pcs	HxLxP	kg	m <sup>3</sup>
	1	470x424x180	4,1	0,036

	Pz - Pcs	HxLxP	kg	m <sup>3</sup>
	5	500x927x445	20	0,2

	Pz - Pcs	HxLxP	kg	m <sup>3</sup>
	60	2530x800x1200	254	2,43

## Monoblocco

Close-coupled - Monobloc

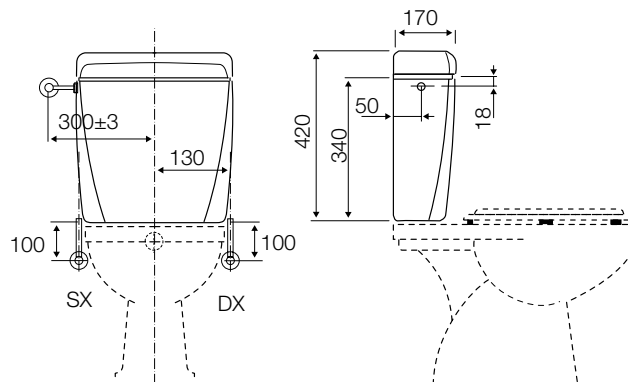



- **Tipologia installazione:** monoblocco
- **Volume scarico:** 6 (pre-regolato), 9 l
- **Materiale fissaggio:** incluso
- **Colore:** bianco
- **Kit tubi pneumatico remoto:** non incluso

- **Installation type:** close-coupled
- **Flush volume:** 6 (standard setting), 9 l
- **Fixing material:** included
- **Colour:** white
- **Pneumatic hoses kit for remote installation:** not included

- **Typologie installation :** monobloc
- **Volume chasse d'eau :** 6 (pré-réglé), 9 l
- **Matériel de fixation :** inclus
- **Couleur :** blanc
- **Kit tuyaux pneumatique à distance :** non inclus

### Coperchio violabile - Violable lid - Couvercle visible

COD.	Scarico Flush - Evacuation	Rubinetto d'arresto Stop valve - Robinet d'arrêt	Attacco Water inlet - Alimentation	
VS0834901	6 l + STOP	1/2"	alto - high - haut	5
VS0834001	6 l + STOP	-	alto - high - haut 1/2"	5

	Pz - Pcs	HxLxP	kg	m <sup>3</sup>
	1	470x424x180	3,8	0,036

	Pz - Pcs	HxLxP	kg	m <sup>3</sup>
	5	500x924x445	19	0,2

	Pz - Pcs	HxLxP	kg	m <sup>3</sup>
	60	2530x800x1200	236	2,43

## Bassa posizione

Low level installation - Position basse

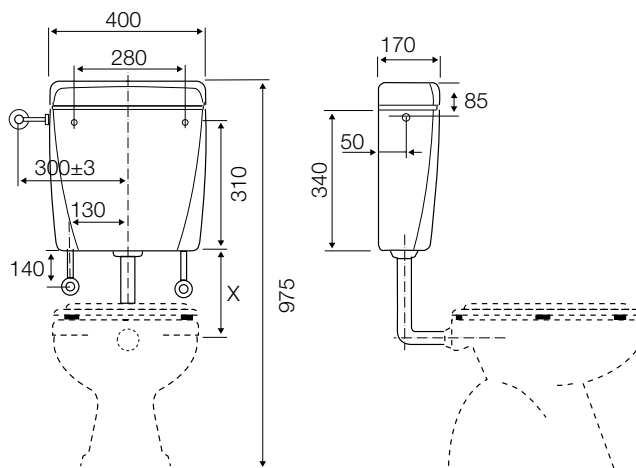

- **Tipologia installazione:** bassa posizione
- **Volume scarico:** 6 (pre-regolato), 9 l
- **Materiale fissaggio:** incluso
- **Colore:** bianco
- **Kit tubi pneumatico remoto:** non incluso

- **Installation type:** low position
- **Flush volume:** 6 (standard setting), 9 l
- **Fixing material:** included
- **Colour:** white
- **Pneumatic hoses kit for remote installation:** not included

- **Typologie installation :** basse position
- **Volume chasse d'eau :** 6 (pré-réglé), 9 l
- **Matériel de fixation :** inclus
- **Couleur :** blanc
- **Kit tuyaux pneumatique à distance :** non inclus

COD.	Scarico Flush - Evacuation	Tubo Flush pipe - Tube	Rubinetto d'arresto Stop valve Robinet d'arrêt	Attacco Water inlet Alimentation	
VS0834501 •	6 l + STOP	si - yes	1/2"	alto - high - haut	5
VS0833701 •	6 l + STOP	no	1/2"	alto - high - haut	5

- Ad esaurimento. - Sell out. - Fin de stock.

	Pz - Pcs	HxLxP	kg	m <sup>3</sup>
	1	470x424x180	4,1	0,036

	Pz - Pcs	HxLxP	kg	m <sup>3</sup>
	5	500x924x445	20,5	0,2

	Pz - Pcs	HxLxP	kg	m <sup>3</sup>
	60	2530x800x1200	254	2,43

## Monoblocco

Close-coupled - Monobloc

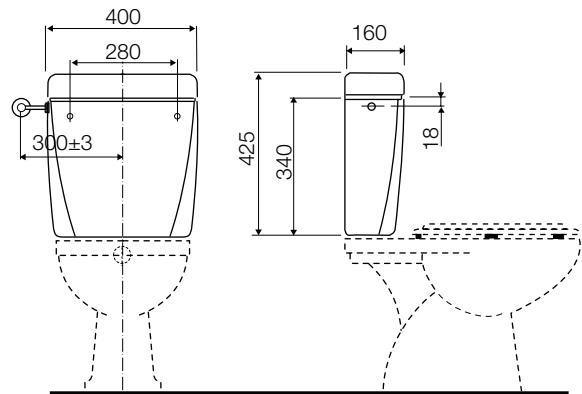

- **Tipologia installazione:** monoblocco
- **Volume scarico:** 6/3 (pre-regolato), 9/3 l
- **Materiale fissaggio:** incluso
- **Colore:** bianco
- **Kit tubi pneumatico remoto:** non incluso

- **Installation type:** close-coupled
- **Flush volume:** 6/3 (standard setting), 9/3 l
- **Fixing material:** included
- **Colour:** white
- **Pneumatic hoses kit for remote installation:** not included

- **Typologie installation :** monobloc
- **Volume chasse d'eau :** 6/3 (pré-réglé), 9/3 l
- **Matériel de fixation :** inclus
- **Couleur :** blanc
- **Kit tuyaux pneumatique à distance :** non inclus

### Coperchio violabile - Violable lid - Couvercle visible

COD.	Scarico Flush - Evacuation	Rubinetto d'arresto Stop valve - Robinet d'arrêt	Attacco Water inlet - Alimentation	
VS0831501 •	6/3 l	-	alto - high 3/8"	5

- Ad esaurimento. - Sell out. - Fin de stock.

	Pz - Pcs	HxLxP	kg	m <sup>3</sup>
	1	470x424x180	4,1	0,36

	Pz - Pcs	HxLxP	kg	m <sup>3</sup>
	5	500x927x445	20,5	0,2

	Pz - Pcs	HxLxP	kg	m <sup>3</sup>
	60	2530x800x1200	254	2,46



# ACCESSORI PER CASSETTE ESTERNE

ACCESSORIES FOR EXPOSED FLUSH CISTERNS

ACCESSOIRES POUR RÉSERVOIRS APPARENTS

## Tubo di scarico Ø<sub>IN</sub> 50

Flush pipe Ø<sub>IN</sub> 50

Tube d'évacuation Ø<sub>IN</sub> 50



COD.	Ø <sub>OUT</sub>	L	Colore - Colour - Couleur	
VS0815201	44	230	bianco - white - blanc	1
VS0815203 •	44	230	champagne	1
VS0815001	32	325	bianco - white - blanc	1
VS0815035 •	32	325	cromo lucido - polished chrome - chromé brillant	1
VS0815101	40	325	bianco - white - blanc	1
VS0815103 •	40	325	champagne	1
VS0815105 •	40	325	grigio manhattan - manhattan grey - gris manhattan	1
VS0815117 •	40	325	visone beige - beige - vison beige	1
VS0815301	32	600	bianco - white - blanc	1
VS0815303 •	32	600	champagne	1
VS0815313 •	32	600	rosa sussurrato - pale pink - rose pastel	1
VS0815317 •	32	600	visone beige - beige - vison beige	1
VS0815401	32	1000	bianco - white - blanc	1
VS0815405 •	32	1000	grigio manhattan - manhattan grey - gris manhattan	1
VS0815409 •	32	1000	azzurro sussurrato - pale blue - bleu azur	1
VS0815417 •	32	1000	visone beige - beige - vison beige	1
VS0815421 •	32	1000	pergamon	1

• Ad esaurimento. - Sell out. - Fin de stock.

## Tubo di scarico prolungato scomponibile Ø 50/32 L 980

Sectional, extended flush  
pipe Ø 50/32 - length 980

Tube d'évacuation rallongé  
réglable Ø 50/32 L 980



COD.	Colore - Colour - Couleur	
VS0815501	bianco - white - blanc	1

## Ricambi - Spare parts - Pièces de rechange

### Kit completo di manicotto di giunzione e accessori di fissaggio tubi per cassetta alta posizione

*Kit with connection sleeve and fastening material for sectional pipes used with high-level cisterns*

*Kit complet de manchon de liaison et accessoires de fixation pour tubes pour réservoir de chasse haute*



<b>COD.</b>	<b>Colore - Colour - Couleur</b>	
VS0817001	bianco - white - blanc	1
VS0817003 •	champagne	1

• Ad esaurimento. - Sell out. - Fin de stock.

### Tubo di scarico Ø 50/32 L 1000 non ingombro

*Space-saving flush pipe Ø 50/32 - length 1000*

*Tube d'évacuation Ø 50/32 L 1000 faible encombrement*



<b>COD.</b>	<b>Colore - Colour - Couleur</b>	
VS0815601	bianco - white - blanc	1
VS0815603 •	champagne	1

• Ad esaurimento. - Sell out. - Fin de stock.

### Tubo di risciacquo esterno scomponibile Ø 32 per cassetta Murex

*Sectional, external ABS flush pipe Ø 32 for Murex cistern*

*Tube d'évacuation réglable externe Ø 32 pour réservoir Murex*



<b>COD.</b>	<b>D</b>	<b>H</b>	<b>Colore - Colour - Couleur</b>	
VS0815071	32	2000	bianco - white - blanc	1

## Accessori - Accessories - Accessoires

### Morsetto per vaso

*Key-seal for toilets*

*Joint pour cuvette*



<b>COD.</b>	<b>D</b>	
VS0816001	32	10
VS0816003	40	10
VS0816005	44	10

### Tubo di risciacquo dietro parete Ø 56/40, completo di morsetto Ø 40

*Flush pipe for concealed  
installation Ø 56/40, with  
rubber adaptor Ø 40*

*Tube d'évacuation derrière  
cloison Ø 56/40, avec joint Ø 40*



<b>COD.</b>	
VS0815999	1

## Ricambi - Spare parts - Pièces de rechange

### Morsetto per tubo di risciacquo

*Key-seal for flush pipe*

*Étau pour tuyau de rinçage*



<b>COD.</b>	
VS0802016	10

## Tubo di cacciata a 2 pezzi in PP e HDPE Ø 32

PP and HDPE 2-piece flush pipe Ø 32

Tube de chasse en deux parties en PP et HDPE Ø 32

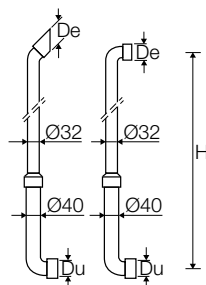

COD.	De-Du	$\alpha$	H max	
VS0700098	32	45° PP	1600	50
VS0700099	32	90° PP	1600	50
VS0335001	32	45° HDPE	1765	20
VS0335003	32	90° HDPE	1765	20

## Ricambi - Spare parts - Pièces de rechange

### Guarnizione singolo labbro PP

PP 1-lip seal

Joint à une lèvre PP



COD.	$\emptyset$	
VS0391320	32	20

Per COD. - For codes - Pour réf. VS0700098 - VS0700099.

### Morsetto per scarico 45° HDPE

Grommet for 45° HDPE elbow

Étau pour évacuation 45° HDPE



COD.	$\emptyset$	
VS0334021	40	50

Per COD. - For codes - Pour réf. VS0335001 - VS0335003.

## Accessori - Accessories - Accessoires

### Morsetto per vaso

Key-seal for toilets

Joint pour cuvette



COD.	D	
VS0816001	32	10
VS0816003	40	10
VS0816005	44	10

### Diffusore turca per tubi Ø 32

Spreader for squatting pan  
for Ø 32 flush pipes

Queue de carpe pour  
WC à la turque Ø 32



COD.	Colore - Colour - Couleur	
VS0815083	bianco - white - blanc	5

### Curva di risciacquo Ø 32-90° per raccordo della cassetta ad alta posizione, completa di rosone

Flush pipe Ø 32-90°  
for high-level cistern,  
complete with flange

Coude d'évacuation Ø 32-90°  
pour raccord du réservoir de  
chasse haute, avec rosace



COD.	Colore - Colour - Couleur	
VS0815801	bianco - white - blanc	1

Per COD. - For codes - Pour réf. VS0700099.

### Curva di risciacquo Ø 32-45° in ottone per cassetta ad alta posizione, completa di rosone

Brass flush bend Ø 32-45° for  
high-level cistern, with flange

Coude d'évacuation Ø 32-45°  
en laiton chromé pour réservoir  
de chasse haute, avec rosace



COD.	Colore - Colour - Couleur	
VS0815064	cromo lucido - polished chrome - chromé brillant	1

Per COD. - For codes - Pour réf. VS0700098-VS0335001

## Ricambi - Spare parts - Pièces de rechange

### Rosone per tubi di cacciata ABS cromato Ø 32-45°

ABS chrome-plated flange  
Ø 32-45° for flush pipes

Rosace pour tubes de chasse  
ABS chromé Ø 32-45°



COD.	Colore - Colour - Couleur	
VS0337001	cromo lucido - polished chrome - chromé brillant	20

### Kit accessori, viti, tasselli ed elementi di fissaggio per cassetta esterne a parete

Accessories kit with screw,  
fasteners and fixing elements  
for wall exposed cisterns

Kit accessoires, vis, chevilles,  
éléments de fixation pour  
mur réservoirs apparents

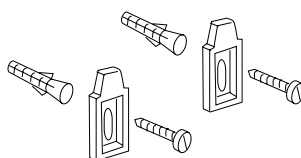

COD.	
VS0810115	1

Il kit contiene due viti, 2 tasselli e 2 elementi di fissaggio. - The kit include 2 screws, 2 fasteners and 2 fixing elements. - Le kit contient deux vis, 2 chevilles et 2 éléments de fixation.

### Kit accessori, viti, tasselli ed elementi di fissaggio per Atlanta, Solea e Island monoblocco

Accessories kit with screw,  
fasteners and fixing elements  
for cisterns close-coupled  
Atlanta, Solea and Island

Kit accessoires, vis,  
chevilles, éléments de  
fixation pour Atlanta, Solea  
et Island monobloc

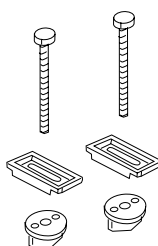

COD.	
VS0822015	1

Il kit contiene due viti, 2 tasselli e 2 elementi di fissaggio. - The kit include 2 screws, 2 fasteners and 2 fixing elements. - Le kit contient deux vis, 2 chevilles et 2 éléments de fixation.

### Kit tubi collegamento pneus 1 quantità, 2,5 m

Connection pipes for pneumatic  
mechanism, single flush, 2.5 m

Kit tube de raccordement  
pneumatique évacuation  
totale 2,5 m



**COD.**



VS0872204 \*

1

\* Solo per applicazioni a comando remotato (azionamento a distanza). - For remote control applications. - eusement pour applications à commande à distance (actionnement à distance).

### Kit tubi collegamento pneus 2 quantità, 2,5 m

Connection pipes for pneumatic  
mechanism, dual flush, 2.5 m

Kit tubes de raccordement  
pneumatiques 2 quantités 2,5 m

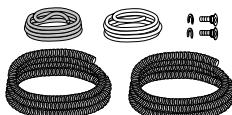

**COD.**



VS0872206 \*

1

\* Solo per applicazioni a comando remotato (azionamento a distanza). - For remote control applications. - eusement pour applications à commande à distance (actionnement à distance).

### ATLANTA2 - SOLEA Allacciamento dal basso DX-SX completo di kit rubinetto d'arresto

Valve kit for inlet from  
below, right-left side

Raccordement par le bas droit-  
gauche avec kit robinet d'arrêt

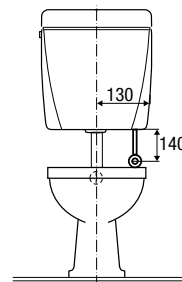
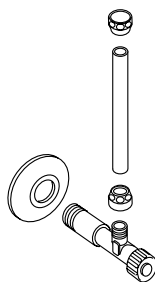

**COD.**



VS0810114

1

**ATLANTA2 - ISLAND2**  
**Allacciamento**  
**posteriore completo di**  
**kit rubinetto d'arresto**

*Inlet valve kit - rear connection*

*Raccordement arrière*  
*avec kit robinet d'arrêt*

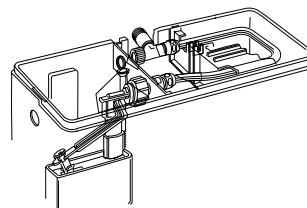
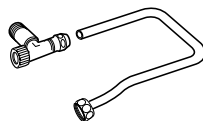

**COD.**



VS0810181 •

1

• Ad esaurimento. - Sell out. - Fin de stock.

**MIDA - MUREX**  
**Allacciamento**  
**posteriore completo di**  
**kit rubinetto d'arresto**

*Inlet valve kit - rear connection*

*Raccordement arrière*  
*avec kit robinet d'arrêt*

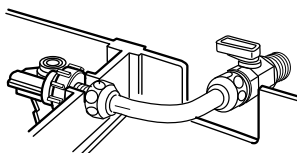

**COD.**



VS0810199

G 3/8"x10

1

VS0810998

G 1/2"x10

1



Lined writing area with 20 horizontal lines. The top 8 lines are pre-filled with the following symbols from right to left: a vertical bar, a swastika, a vertical bar, a flame, a bird, a crescent moon, a stylized 'U' shape, and a triangle with a dot. The remaining 12 lines are blank.

# RICAMBI

*SPARE PARTS - PIÈCES DE RECHANGE*

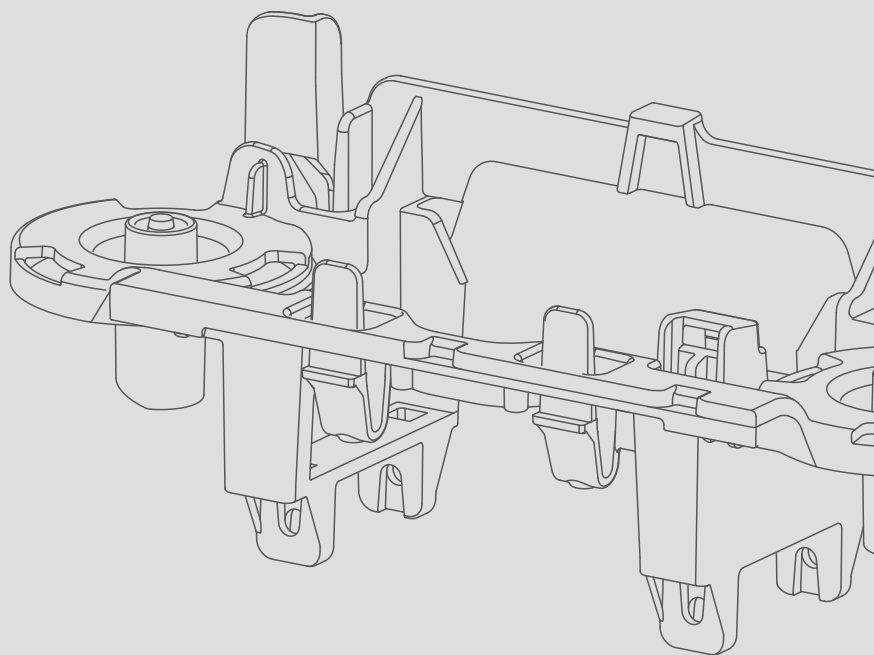
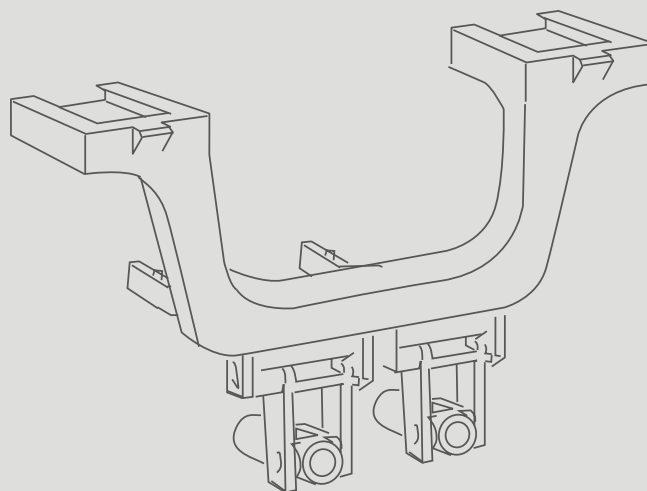
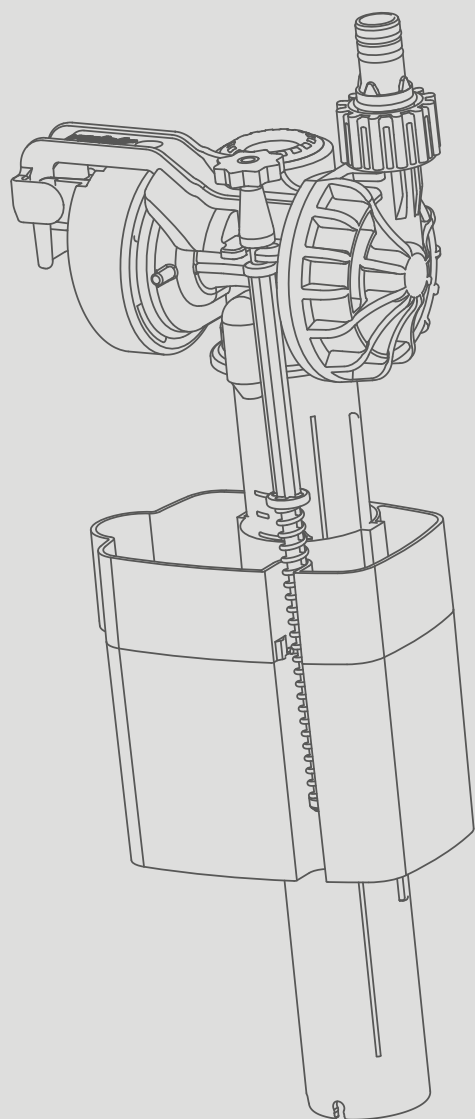



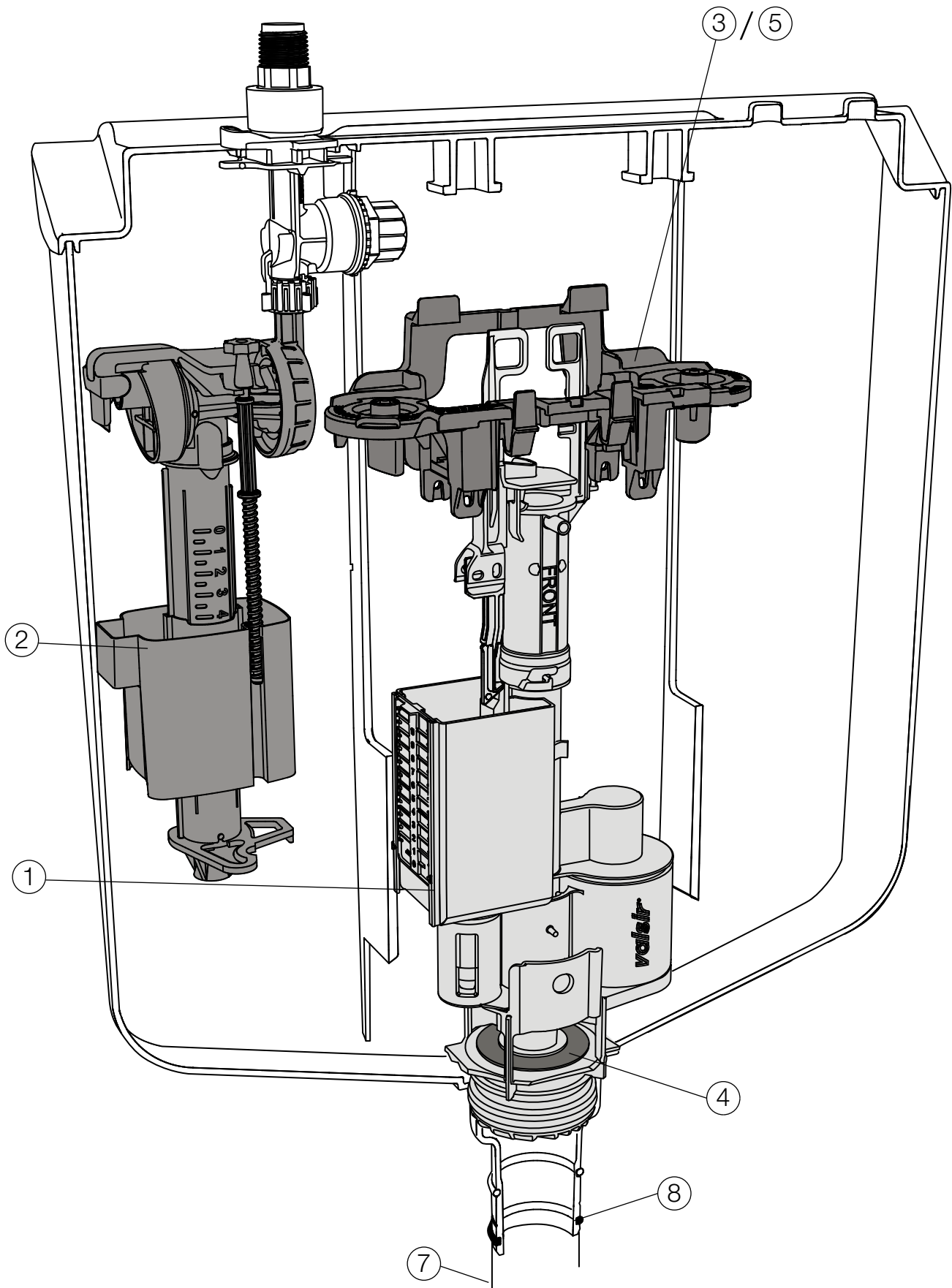

**RICAMBI: LA GARANZIA PER IL FUTURO**

*SPARE PARTS: THE GUARANTEE FOR THE FUTURE*

*PIÈCES DE RECHANGE : LA GARANTIE POUR LE FUTUR*

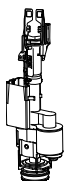
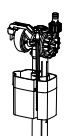
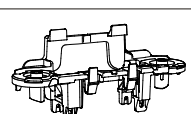

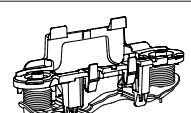
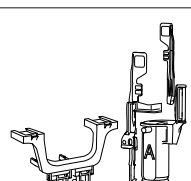
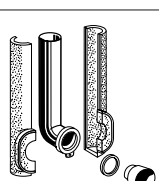

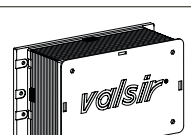

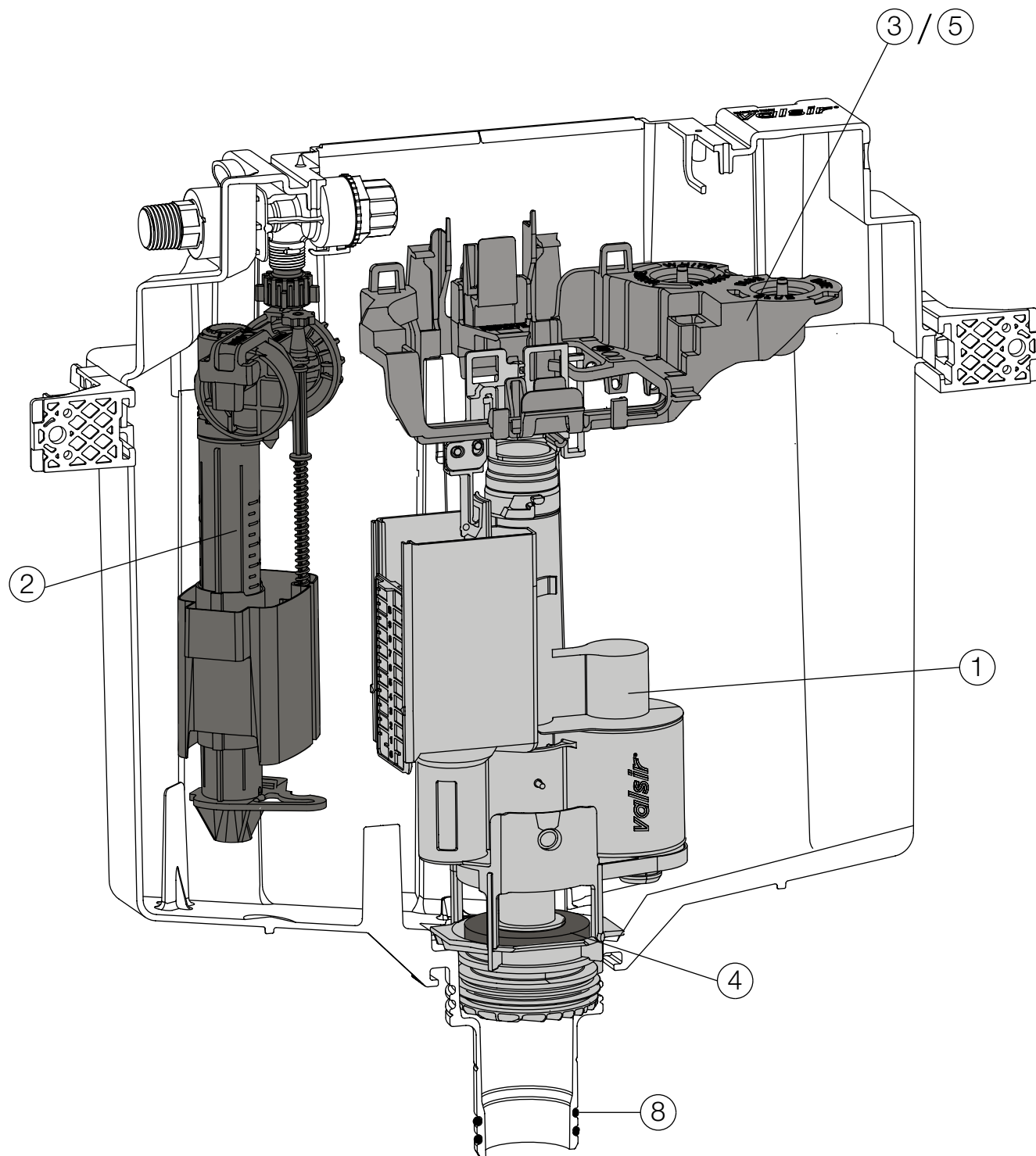

## Ricambi - Spare parts - Pièces de rechange

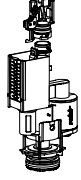
			COD.	
①		Valvola per Tropea S/Tropea3 meccanica <i>Tropea S/Tropea3 mechanical valve</i> <i>Vanne pour Tropea S/Tropea 3 mécanique</i>	VS0866690	1
②		Rubinetto galleggiante Compact <i>Compact float valve</i> <i>Robinet flotteur Compact</i>	VS0866693	1
③		Blocco centrale Tropea S <i>Tropea S central block</i> <i>Bloc central reservoir Tropea S</i>	VS0866794	1
④		Guarnizione per valvola <i>Seal for outlet valve</i> <i>Joint de mécanisme</i>	VS0866603	10
⑤		Kit trasformazione da meccanico a pneumatico Tropea S <i>Tropea S mechanical to pneumatic conversion kit</i> <i>Kit de commutation de mécanique à pneumatique Tropea S</i>	VS0866792	1
⑥		Kit trasformazione da pneumatico a meccanico <i>Pneumatic to mechanical conversion kit</i> <i>Kit de commutation de pneumatique à mécanique</i>	VS0866696	1
⑦		Kit tubo di risciacquo per Tropea S/Tropea3 <i>Flush pipe kit for Tropea S/Tropea3</i> <i>Kit tuyau de rinçage pour Tropea S/Tropea3</i>	VS0866580	1
⑧		O-ring per bocchettone (2 pz) <i>O-ring for connection pipe (2 pcs)</i> <i>Joint torique pour embout (2 pcs)</i>	VS0820163	1
⑨		Guarnizione a due labbra per tubo di cacciata <i>2-lip seal for flush pipe</i> <i>Joint en deux lèvres pour tuyau de chasse</i>	VS0820119	1
⑩		Cassa di protezione <i>Protective case</i> <i>Boîtier de protection</i>	VS0866625	1

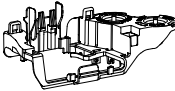

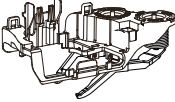
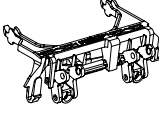

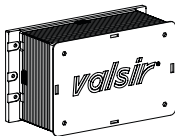
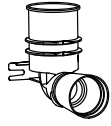
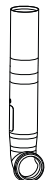

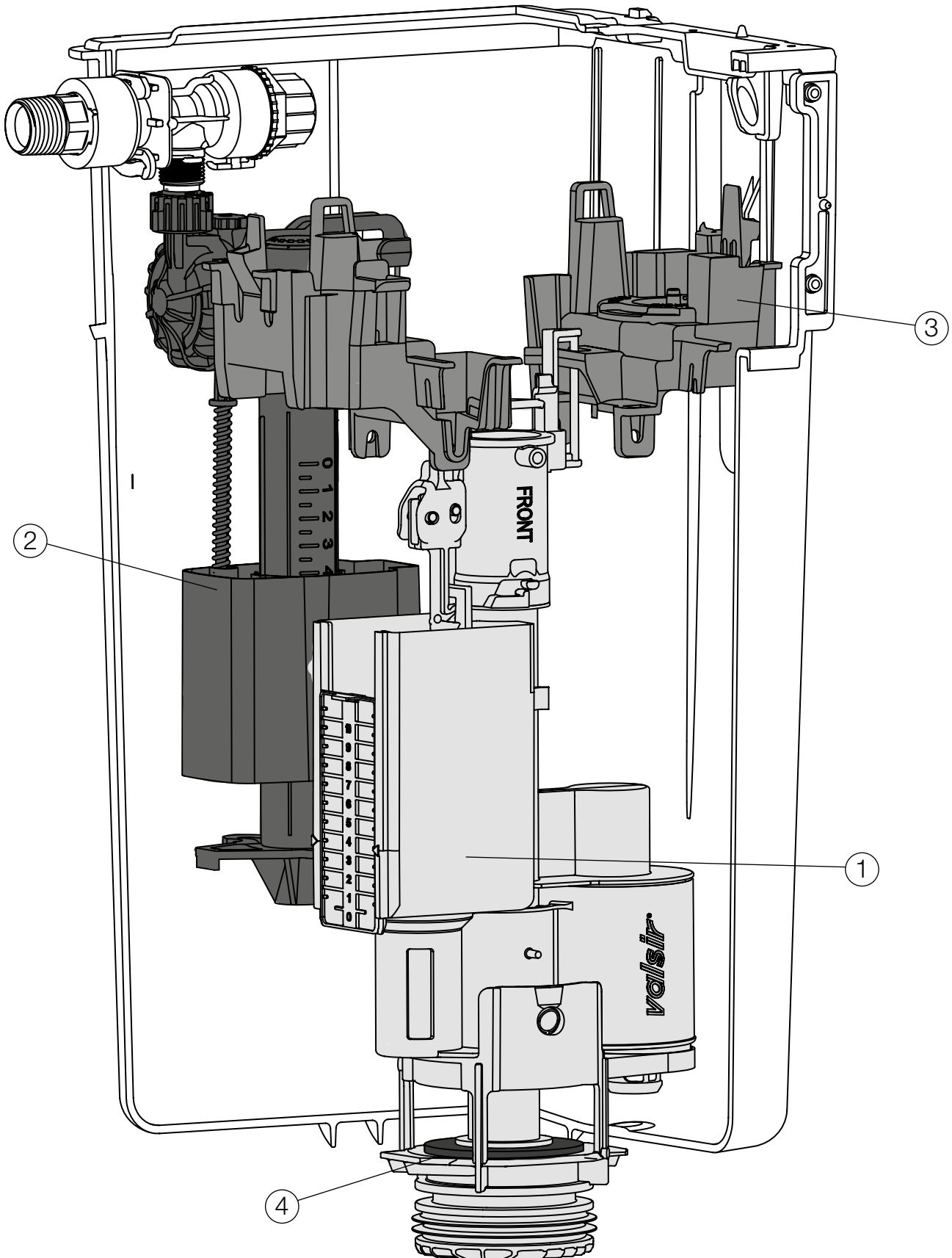
## Ricambi - Spare parts - Pièces de rechange

			COD.	
①		Valvola per Winner S meccanica <i>Winner S mechanical valve</i> <i>Vanne pour Winner S mécanique</i>	VS0866790	1
②		Rubinetto galleggiante Compact <i>Compact float valve</i> <i>Robinet flotteur Compact</i>	VS0866693	1
③		Blocco centrale Winner S <i>Winner S central block</i> <i>Bloc central reservoir Winner S</i>	VS0866994	1
④		Guarnizione per valvola <i>Seal for outlet valve</i> <i>Joint de mécanisme</i>	VS0866603	10
⑤		Kit trasformazione da meccanico a pneumatico Winner S <i>Winner S mechanical to pneumatic conversion kit</i> <i>Kit de commutation de mécanique à pneumatique Winner S</i>	VS0866992	1
⑥		Kit trasformazione da pneumatico a meccanico <i>Pneumatic to mechanical conversion kit</i> <i>Kit de commutation de pneumatique à mécanique</i>	VS0866796	1
⑧		O-ring per bocchettone (2 pz) <i>O-ring for connection pipe (2 pcs)</i> <i>Joint torique pour embout (2 pcs)</i>	VS0820163	1
⑨		Guarnizione a due labbra per tubo di cacciata <i>2-lip seal for flush pipe</i> <i>Joint en deux lèvres pour tuyau de chasse</i>	VS0820119	1
⑩		Cassa di protezione <i>Protective case</i> <i>Boîtier de protection</i>	VS0866625	1
⑪		Kit tubo di risciacquo per Winner S H 800/820/880 <i>Flush pipe kit for Winner S H 800/820/880</i> <i>Kit tuyau de rinçage pour Winner S H 800/820/880</i>	VS0863509	1
⑫		Kit tubo di risciacquo per Winner S H 1050/1140 <i>Flush pipe kit for Winner S H 1050/1140</i> <i>Kit tuyau de rinçage pour Winner S H 1050/1140</i>	VS0868284	1

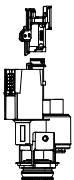
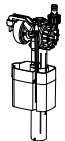
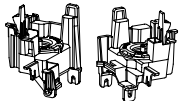
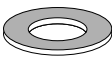
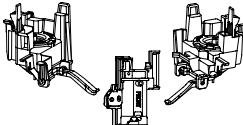
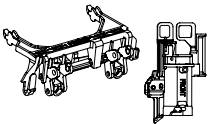

**Ricambi - Spare parts - Pièces de rechange**
**COD.**

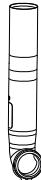
①		Valvola per Cubik S meccanica <i>Cubik S mechanical valve</i> <i>Vanne pour Cubik S mécanique</i>	VS0866890	1
②		Rubinetto galleggiante Compact <i>Compact float valve</i> <i>Robinet flotteur Compact</i>	VS0866693	1
③		Blocco centrale Cubik S <i>Cubik S central block</i> <i>Bloc central reservoir Cubik S</i>	VS0866894	1
④		Guarnizione per valvola <i>Seal for outlet valve</i> <i>Joint de mécanisme</i>	VS0866603	10
⑤		Kit trasformazione da meccanico a pneumatico Cubik S <i>Cubik S mechanical to pneumatic conversion kit</i> <i>Kit de commutation de mécanique à pneumatique Cubik S</i>	VS0866892	1
⑥		Kit trasformazione da pneumatico a meccanico <i>Pneumatic to mechanical conversion kit</i> <i>Kit de commutation de pneumatique à mécanique</i>	VS0866896	1
⑧		O-ring per bocchettone (2 pz) <i>O-ring for connection pipe (2 pcs)</i> <i>Joint torique pour embout (2 pcs)</i>	VS0820163	1
⑨		Guarnizione a due labbra per tubo di cacciata <i>2-lip seal for flush pipe</i> <i>Joint en deux lèvres pour tuyau de chasse</i>	VS0820119	1
⑨		Cassa di protezione <i>Protective case</i> <i>Boîtier de protection</i>	VS0866625	1
⑩		Kit tubo di risciacquo per Cubik S H 880 <i>Flush pipe kit for Cubik S H 880</i> <i>Kit tuyau de rinçage pour Cubik S H 880</i>	VS0863565	1
⑪		Kit tubo di risciacquo per Cubik S H 1060 <i>Flush pipe kit for Cubik S H 1060</i> <i>Kit tuyau de rinçage pour Cubik S H 1060</i>	VS0868284	1



# RICAMBI PER IL SISTEMA ARIAPUR

ARIAPUR SYSTEM SPARE PARTS

PIÈCES DE RECHANGE ARIAPUR

## Distanziale per pareti a murare da 80 a 105 mm

Spacer for masonry walls  
from 80 to 105 mm

Ecarteur pour paroi  
de 80 à 105 mm

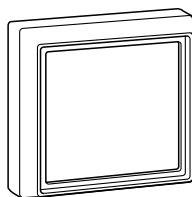

**COD.**

VS0874011



1

## Kit due squadrette e viti per il fissaggio del contenitore ventilatore alle pareti o intercapedini

Kit with two brackets and screws  
for fixing the ventilator container  
to the walls or duct walls

Kit de deux équerres et vis  
pour la fixation du boîtier  
du ventilateur aux parois

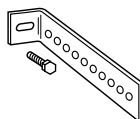

**COD.**

VS0874012



1

## Contenitore alloggio ventilatore

Ventilator housing container

Boîtier de logement  
du ventilateur

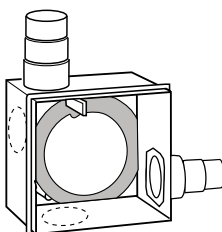

**COD.**

VS0874013



1

## Placca copertura con filtro

Cover plate with filter

Plaque de fermeture avec filtre

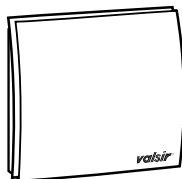

**COD.**

VS0874015



1

## Ventilatore Ariapur

Ariapur ventilator  
Ventilateur Ariapur

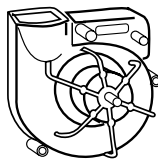

### COD.

VS0874016



1

## Tubo di risciacquo girevole per il collegamento al sistema Ariapur

Flush pipe for connection to Ariapur system

Tuyau de rinçage rotatif pour le raccordement au système Ariapur

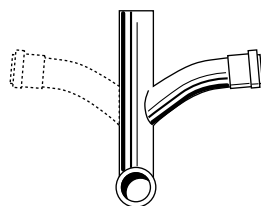

### COD.

VS0866641

### Mod.

Tropea S, Winner S, Tropea3



1

VS0874022

Winner 2

1

# RICAMBI PLACCHE

## PUSH PLATES SPARE PARTS

### PIÈCES DE RECHANGE PLAQUES

#### P1-P2 MECC

COD.

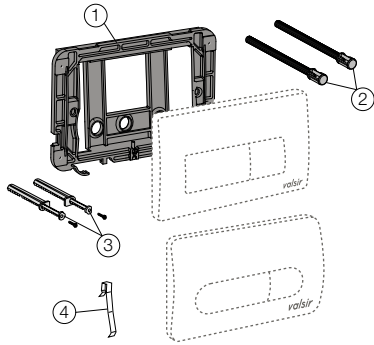

①	Controplacca completa di viti e distanziatori <i>Plate support frame complete with screws and spacers</i> <i>Contreplaque, vis et entretoises</i>	VS0871348	1
②	Viti di azionamento <i>Screws for control mechanisms</i> <i>Vis d'actionnement</i>	VS0866695	1
③	Distanziatori fissaggio placca <i>Spacer for attaching plate</i> <i>Entretoises de fixation plaque</i>	VS0864166	1
④	Molla <i>Spring</i> <i>Ressort</i>	VS0822127	1

#### P1-P2 PNEU

COD.

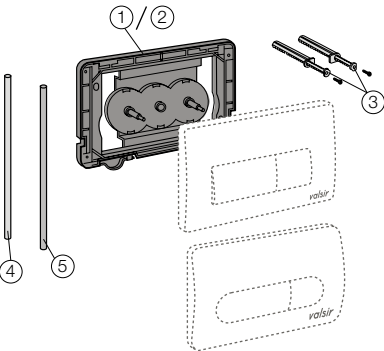

①	Controplacca completa di distanziatori e tubi PVC dal 2004 al 2012 <i>Plate support frame complete with spacer and PVC pipes from 2004 to 2012</i> <i>Contreplaque, entretoises et tuyaux PVC de 2004 à 2012</i>	VS0871548	1
②	Controplacca completa di distanziatori e tubi PVC dal 2013 <i>Plate support frame complete with spacer and PVC pipes from 2013</i> <i>Contreplaque, entretoises et tuyaux PVC de 2013</i>	VS0871549	1
③	Distanziatori fissaggio placca <i>Spacer for attaching plate</i> <i>Entretoises de fixation plaque</i>	VS0864166	1
④	Tubo PVC bianco Ø 6x4 - 360 mm <i>White PVC pipe Ø 6x4 - 360 mm</i> <i>Tube PVC blanc Ø 6x4 - 360 mm</i>	VS0804697	1
⑤	Tubo PVC azzurro Ø 6x4 - 360 mm <i>Blue PVC pipe Ø 6x4 - 360 mm</i> <i>Tube PVC bleu Ø 6x4 - 360 mm</i>	VS0804698	1

**P3-P4-P5 MECC**

**COD.**



	①	Kit controplacca completa Plate support frame complete Kit controplacca completa	VS0871349	1
	②	Viti di azionamento Screws for control mechanisms Vis d'actionnement	VS0866695	1
	③	Distanziatori fissaggio placca Spacer for attaching plate Entretoises de fixation plaque	VS0864166	1

**P3-P4-P5 PNEU**

**COD.**



	①	Kit controplacca completa Plate support frame complete Kit controplacca completa	VS0871550	1
	②	Distanziatori fissaggio placca Spacer for attaching plate Entretoises de fixation plaque	VS0864166	1
	③	Tubo PVC bianco Ø 6x4 - 360 mm White PVC pipe Ø 6x4 - 360 mm Tube PVC blanc Ø 6x4 - 360 mm	VS0804697	1
	④	Tubo PVC azzurro Ø 6x4 - 360 mm Blue PVC pipe Ø 6x4 - 360 mm Tube PVC bleu Ø 6x4 - 360 mm	VS0804698	1

**VS08717XX**

**TROPEA3 - CUBIK - EVOLUT PNEU**

**COD.**

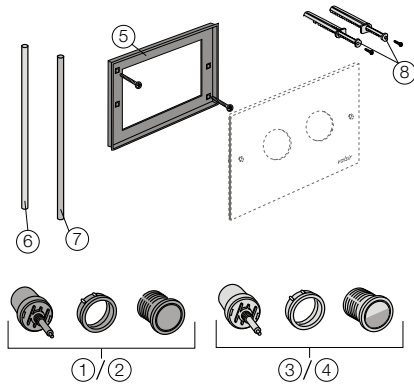

①	Kit pulsante scarico totale cromo lucido Full flush button kit polished chrome Kit poussoir de commande débit total - chromé brillant	VS0875313	1
②	Kit pulsante scarico totale cromo satinato Full flush button kit satin chrome Kit poussoir de commande débit total - chromé mat	VS0875317	1
③	Kit pulsante 1/2 scarico cromo lucido 1/2 flush button kit polished chrome Kit poussoir de commande 1/2 débit - chromé brillant	VS0875315	1
④	Kit pulsante 1/2 scarico cromo satinato 1/2 flush button kit satin chrome Kit poussoir de commande 1/2 débit - chromé mat	VS0875319	1
⑤	Contro telaio con viti Frame with screws Contre plaque avec vis	VS0868749	1
⑥	Tubo PVC bianco Ø 6x4 - 360 mm White PVC pipe Ø 6x4 - 360 mm Tube PVC blanc Ø 6x4 - 360 mm	VS0804697	1
⑦	Tubo PVC azzurro Ø 6x4 - 360 mm Blue PVC pipe Ø 6x4 - 360 mm Tube PVC bleu Ø 6x4 - 360 mm	VS0804698	1
⑧	Distanziatori fissaggio placca Spacer for attaching plate Entretoises de fixation plaque	VS0864166	1

**VS08725XX - VS08705XX - VS08708XX**

**WINNER - TROPEA2 MECC**

**COD.**

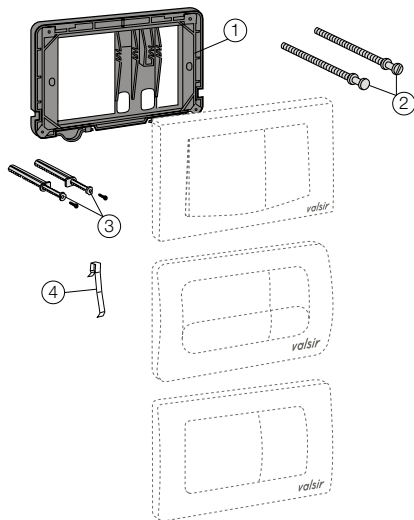

①	Controplacca completa di viti e distanziatori Plate support frame complete with screws and spacers Contreplaque, vis et entretoises	VS0870848	1
②	Vite di comando scarico totale e 1/2 scarico Screw for push plate, total and 1/2 flush Vis de commande débit total et 1/2 débit	VS0820118	1
③	Distanziatori fissaggio placca Spacer for attaching plate Entretoises de fixation plaque	VS0864166	1
④	Molla Spring Ressort	VS0822127	1

**VS08707XX**  
**WINNER - TROPEA2 PNEU**

**COD.**



	①	Kit pulsante scarico totale cromo lucido <i>Full flush button kit polished chrome</i> Kit poussoir de commande débit total - chromé brillant	VS0875313	1
	②	Kit pulsante scarico totale cromo satinato <i>Full flush button kit satin chrome</i> Kit poussoir de commande débit total - chromé mat	VS0875317	1
	③	Kit pulsante 1/2 scarico cromo lucido <i>1/2 flush button kit polished chrome</i> Kit poussoir de commande 1/2 débit - chromé brillant	VS0875315	1
	④	Kit pulsante 1/2 scarico cromo satinato <i>1/2 flush button kit satin chrome</i> Kit poussoir de commande 1/2 débit - chromé mat	VS0875319	1
	⑤	Tubo PVC bianco Ø 6x4 - 360 mm <i>White PVC pipe Ø 6x4 - 360 mm</i> Tube PVC blanc Ø 6x4 - 360 mm	VS0804697	1
	⑥	Tubo PVC azzurro Ø 6x4 - 360 mm <i>Blue PVC pipe Ø 6x4 - 360 mm</i> Tube PVC bleu Ø 6x4 - 360 mm	VS0804698	1
	⑦	Distanziatori fissaggio placca <i>Spacer for attaching plate</i> Entretoises de fixation plaque	VS0864166	1

**CRYSTAL - INOX - BLACK & WHITE**

**Finitura - Finishing**

**COD.**

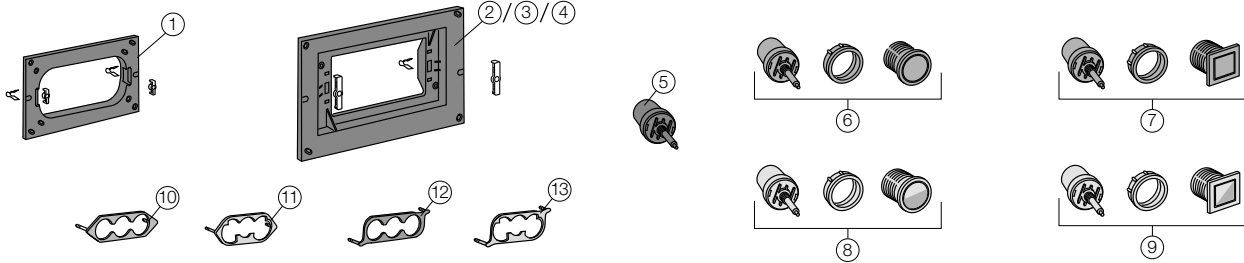

①	Controplacca SMALL Plate support frame SMALL Contreplaque SMALL	lucido - polished - brillant	VS0875335	1
		satinato - satin - satin	VS0875329	1
②	Controplacca MEDIUM Plate support frame MEDIUM Contreplaque MEDIUM	lucido - polished - brillant	VS0875337	1
		satinato - satin - satin	VS0875331	1
③	Controplacca dal 2009 al 2011 LARGE Plate support frame from 2009 to 2011 LARGE Contreplaque de 2009 à 2011 LARGE	lucido - polished - brillant	VS0875339	1
		satinato - satin - satin	VS0875333	1
④	Controplacca dal 2012 LARGE Plate support frame to 2012 LARGE Contreplaque de 2012 LARGE	lucido - polished - brillant	VS0875338	1
		satinato - satin - satin	VS0875332	1
⑤	Meccanismo di comando pneus Pneumatic control mechanism Mécanisme de commande pneus		VS0875341	1
⑥	Kit pulsante scarico totale - tondo Full flush button kit - round Kit bouton d'évacuation totale - rond	lucido - polished - brillant	VS0875313	1
		satinato - satin - satin	VS0875317	1
⑦	Kit pulsante scarico totale - quadro Full flush button kit - square Kit bouton d'évacuation totale - carré	lucido - polished - brillant	VS0875305	1
		satinato - satin - satin	VS0875309	1
⑧	Kit pulsante 1/2 scarico - tondo 1/2 flush button kit - round Kit bouton de 1/2 évacuation - rond	lucido - polished - brillant	VS0875315	1
		satinato - satin - satin	VS0875319	1
⑨	Kit pulsante 1/2 scarico - quadro 1/2 flush button kit - square Kit bouton de 1/2 évacuation - carré	lucido - polished - brillant	VS0875307	1
		satinato - satin - satin	VS0875311	1
⑩	Centratore inox, pulsante tondo Stainless steel centre finder, round button Centreur inox, bouton rond	SMALL dal - to 2009	VS0875109	1
⑪	Centratore inox, pulsante quadro Stainless steel centre finder, square button Centreur inox, bouton carré	MEDIUM/LARGE 2009-2011	VS0875110	1
⑫	Centratore inox, pulsante tondo Stainless steel centre finder, round button Centreur inox, bouton rond		VS0875297	1
⑬	Centratore inox, pulsante quadro Stainless steel centre finder, square button Centreur inox, bouton carré	MEDIUM/LARGE dal - to 2012	VS0875298	1

**WOOD - STONE - FANTASY**

**Finitura - Finishing**

**COD.**

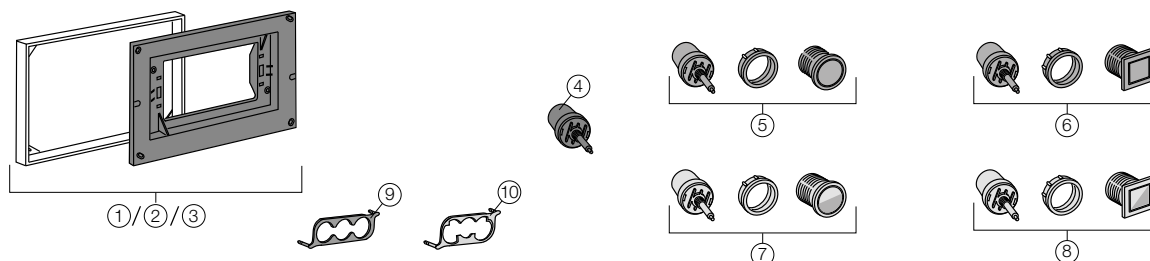

①	Kit controplacca e cornice MEDIUM <i>Kit plate support frame MEDIUM</i> <i>Kit contreplaque et cadre MEDIUM</i>	lucido - <i>polished - brillant</i>	VS0875325	1
		satinato - <i>satin - satin</i>	VS0875321	1
②	Kit controplacca e cornice dal 2009 al 2011 LARGE <i>Kit plate support frame from 2009 to 2011 LARGE</i> <i>Kit contreplaque et cadre de 2009 à 2011 LARGE</i>	lucido - <i>polished - brillant</i>	VS0875327	1
		satinato - <i>satin - satin</i>	VS0875323	1
③	Kit controplacca e cornice dal 2012 LARGE <i>Kit plate support frame to 2012 LARGE</i> <i>Kit contreplaque et cadre de 2012 LARGE</i>	lucido - <i>polished - brillant</i>	VS0875328	1
		satinato - <i>satin - satin</i>	VS0875324	1
④	Meccanismo a comando pneus <i>Pneumatic control mechanism</i> <i>Mécanisme de commande pneus</i>		VS0875341	1
⑤	Kit pulsante scarico totale - tondo <i>Full flush button kit - round</i> <i>Kit bouton d'évacuation totale - rond</i>	lucido - <i>polished - brillant</i>	VS0875313	1
		satinato - <i>satin - satin</i>	VS0875317	1
⑥	Kit pulsante scarico totale - quadro <i>Full flush button kit - square</i> <i>Kit bouton d'évacuation totale - carré</i>	lucido - <i>polished - brillant</i>	VS0875305	1
		satinato - <i>satin - satin</i>	VS0875309	1
⑦	Kit pulsante 1/2 scarico - tondo <i>1/2 flush button kit - round</i> <i>Kit bouton de 1/2 évacuation - rond</i>	lucido - <i>polished - brillant</i>	VS0875315	1
		satinato - <i>satin - satin</i>	VS0875319	1
⑧	Kit pulsante 1/2 scarico - quadro <i>1/2 flush button kit - square</i> <i>Kit bouton de 1/2 évacuation - carré</i>	lucido - <i>polished - brillant</i>	VS0875307	1
		satinato - <i>satin - satin</i>	VS0875311	1
⑨	Centratore inox, pulsante tondo <i>Stainless steel centre finder, round button</i> <i>Centreur inox, bouton rond</i>	SMALL dal - to 2009	VS0875109	1
⑩	Centratore inox, pulsante quadro <i>Stainless steel centre finder, square button</i> <i>Centreur inox, bouton carré</i>	MEDIUM/LARGE 2009-2011	VS0875110	1
⑪	Centratore inox, pulsante tondo <i>Stainless steel centre finder, round button</i> <i>Centreur inox, bouton rond</i>		VS0875297	1
⑫	Centratore inox, pulsante quadro <i>Stainless steel centre finder, square button</i> <i>Centreur inox, bouton carré</i>	MEDIUM/LARGE dal - to 2012	VS0875298	1



# RICAMBI COMANDI PNEUMATICI

## PNEUMATIC ACTUATORS SPARE PARTS

### PIÈCES DE RECHANGE COMMANDES PNEUMATIQUE

**VS08722XX**

**COD.**

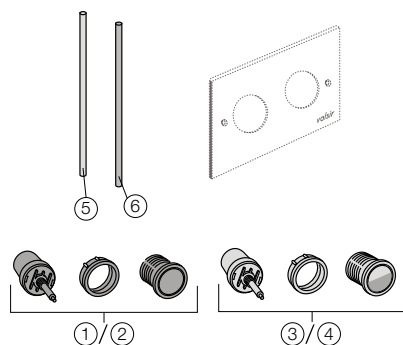

①	Kit pulsante scarico totale cromo lucido <i>Full flush button kit polished chrome</i> <i>Kit poussoir de commande débit total - chromé brillant</i>	VS0875313	1
②	Kit pulsante scarico totale cromo satinato <i>Full flush button kit satin chrome</i> <i>Kit poussoir de commande débit total - chromé mat</i>	VS0875317	1
③	Kit pulsante 1/2 scarico cromo lucido <i>1/2 flush button kit polished chrome</i> <i>Kit poussoir de commande 1/2 débit - chromé brillant</i>	VS0875315	1
④	Kit pulsante 1/2 scarico cromo satinato <i>1/2 flush button kit satin chrome</i> <i>Kit poussoir de commande 1/2 débit - chromé mat</i>	VS0875319	1
⑤	Tubo PVC bianco Ø 6x4 - 360 mm <i>White PVC pipe Ø 6x4 - 360 mm</i> <i>Tube PVC blanc Ø 6x4 - 360 mm</i>	VS0804697	1
⑥	Tubo PVC azzurro Ø 6x4 - 360 mm <i>Blue PVC pipe Ø 6x4 - 360 mm</i> <i>Tube PVC bleu Ø 6x4 - 360 mm</i>	VS0804698	1

**VS0804801**

**COD.**

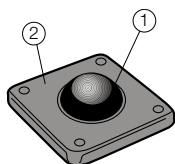

①	Cappuccio copertura pulsante <i>Rubber covering for button</i> <i>Cape de fermeture de poussoir</i>	VS0804824	1
②	Flangia di copertura inox <i>Stainless steel flanged cover plate</i> <i>Bride de couverture inox</i>	VS0804811	1

**VS0804901**

**COD.**

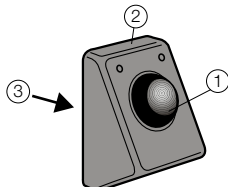

①	Cappuccio copertura pulsante <i>Rubber covering for button</i> <i>Cape de fermeture de poussoir</i>	VS0804824	1
②	Flangia di copertura inox <i>Stainless steel flanged cover plate</i> <i>Bride de couverture inox</i>	VS0804911	1
③	Kit pulsante pneumatico <i>Pneumatic push button kit</i> <i>Kit bouton pneumatique</i>	VS0804902	1

## VS08023XX

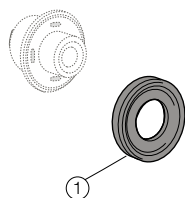

①

Ghiera esterna  
 External nut  
 Cache externe

**Colore**  
**Colour - Couleur**

**COD.**



bianco  
 white  
 blanc

VS0804625

1

cromo lucido  
 polished chrome  
 chromé brillant

VS0804628

1

cromo satinato  
 satin chrome  
 chromé mat

VS0804635

1

dorato  
 gold finish  
 doré

VS0804629 •

1

• Ad esaurimento. - Sell out. - Fin de stock.

## VS08024XX

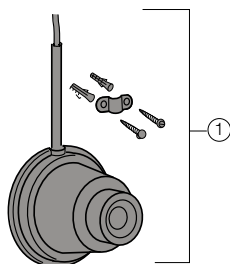

①

Kit ricambio completo  
 Complet spare part kit  
 Kit changement complet

**Colore**  
**Colour - Couleur**

**COD.**



bianco  
 white  
 blanc

VS0804621

1

cromo lucido  
 polished chrome  
 chromé brillant

VS0804622

1

cromo satinato  
 satin chrome  
 chromé mat

VS0804623

1

**RICAMBI STRUTTURE**  
**MOUNTING FRAMES SPARE PARTS**  
**PIÈCES DE RECHANGE STRUCTURES**

---

**Curva tecnica con fascetta antivibrante Ø 50**

*Outlet bend with anti-vibration seal, Ø 50*  
*Coude technique bidet avec joint isolant Ø 50*

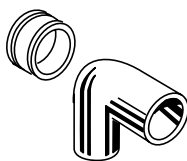

**COD.**

VS0825031



1

**Morsetto per curva tecnica Ø 50x1"1/4 - 1"1/2**

*Ring seal for connection bend Ø 50x1"1/4 - 1"1/2*  
*Joint pour coude technique Ø 50x1"1/4 - 1"1/2*

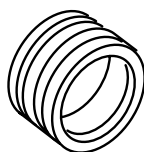

**COD.**

VS0825021



1

**Tappo di protezione Ø 40**

*Protective plug Ø 40*  
*Bouchon de protection Ø 40*

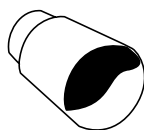

**COD.**

VS0802009



1

**Kit flangia porta raccordi completo di viti per bidet Fixsystem**

*Plate with screws for connection of fittings for Fixsystem bidet*  
*Kit platine porte raccord avec vis pour bidet Fixsystem*

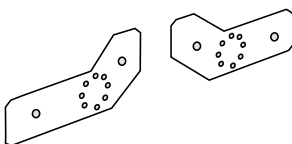

**COD.**

VS0825030



1

## Raccordo in ottone completo di guarnizione e viti

*Brass fitting with seal and screws*  
*Raccord laiton avec joint et vis*

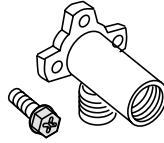

### COD.



VS0825028

3/8" Fx3/8" M

10



VS0825023

1/2" Fx1/2" M

10

## Kit viti, tasselli fissaggio struttura (4 pz) Ø 10

*Screws and anchors for attaching frame (4 pcs) Ø 10*  
*Kit vis, chevilles de fixation de structure (4 pz) Ø 10*

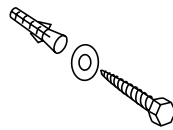

### COD.



VS0805128

1

## Squadretta laterale fissaggio struttura con vite e rondella (1 pz)

*Side bracket for attaching frame with screw and washer (1 pc)*  
*Élément latéral de fixation de la structure avec vis et rondelle (1 pièce)*

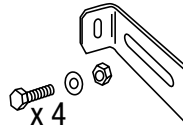

### COD.

### Mod.



VS0824135

Tropea3 S90

1

VS0868613

Winner, Cubik, Evolut Angel, Tropea3 S160

1

## Kit tiranti, tubo PVC, dadi, rondelle fissaggio WC sospeso con coppelle

*Threaded rods, PVC pipe, nuts and washers, for wall-hung pan attachment with protective caps*  
*Kit tiges filetées, tube PVC, écrous, rondelles pour fixations bidet suspendu*

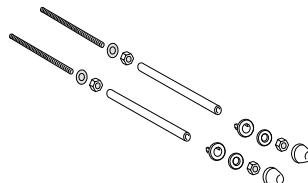

### COD.



VS0820224

1

### Porta curva - modello **Fixsystem**

*Bend support for Fixsystem  
mounting frame*

*Support de coude -  
modèle Fixsystem*



<b>COD.</b>	<b>Mod.</b>	
VS0826072	dal - from 2009	1
VS0826066	2004 - 2008	1

### Porta curva - **modello Block**

*Bend support for Block  
mounting frame*

*Support de coude - modèle Block*



<b>COD.</b>	<b>Mod.</b>	
VS0826065	Winner, Evolut, Cubik, Space, Angel, Tropea2, Tropea3 S160	1
VS0826068	Tropea3 S90	1

### Porta curva WC 3 **posizioni con guida**

*Support for wc bend 3  
positions with guide*

*porte coude WC 3  
positions avec guide*



<b>COD.</b>	<b>Mod.</b>	
 VS0868278	Tropea S, Winner S, Cubik S	1

### **Cannotto PP** **allacciamento WC D 45** **L 195 con morsetto Ø 44**

*PP connection pipe for WC  
D 45 L 195 with Ø 44 grommet*

*Tube PP alimentation WC  
D 45 L 195 avec joint Ø 44*

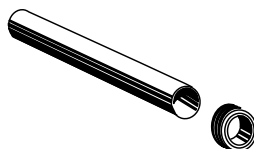

<b>COD.</b>	
VS0803202	1

**Morsetto per  
orinatoio Ø 60x50**

*Seal for urinal Ø 60x50*

*Joint pour urinoir Ø 60x50*



**COD.**

VS0867655



1

**Scheda alimentatore  
per orinatoio Blick**

*Power supply circuit  
board for Blick urinal*

*Carte alimentateur pour urinoir Blick*

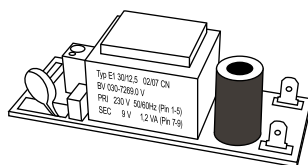

**COD.**

VS0868830



1

**Scheda porta batterie  
per orinatoio Blick**

*Batteries casing for Blick urinal*

*Carte porte-batterie pour urinoir Blick*

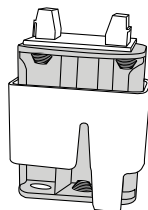

**COD.**

VS0868832



1

**Valvola bistabile per  
orinatoio Blick**

*Bistable valve for Blick urinal*

*Vanne bistable pour urinoir Blick*

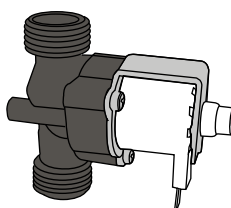

**COD.**





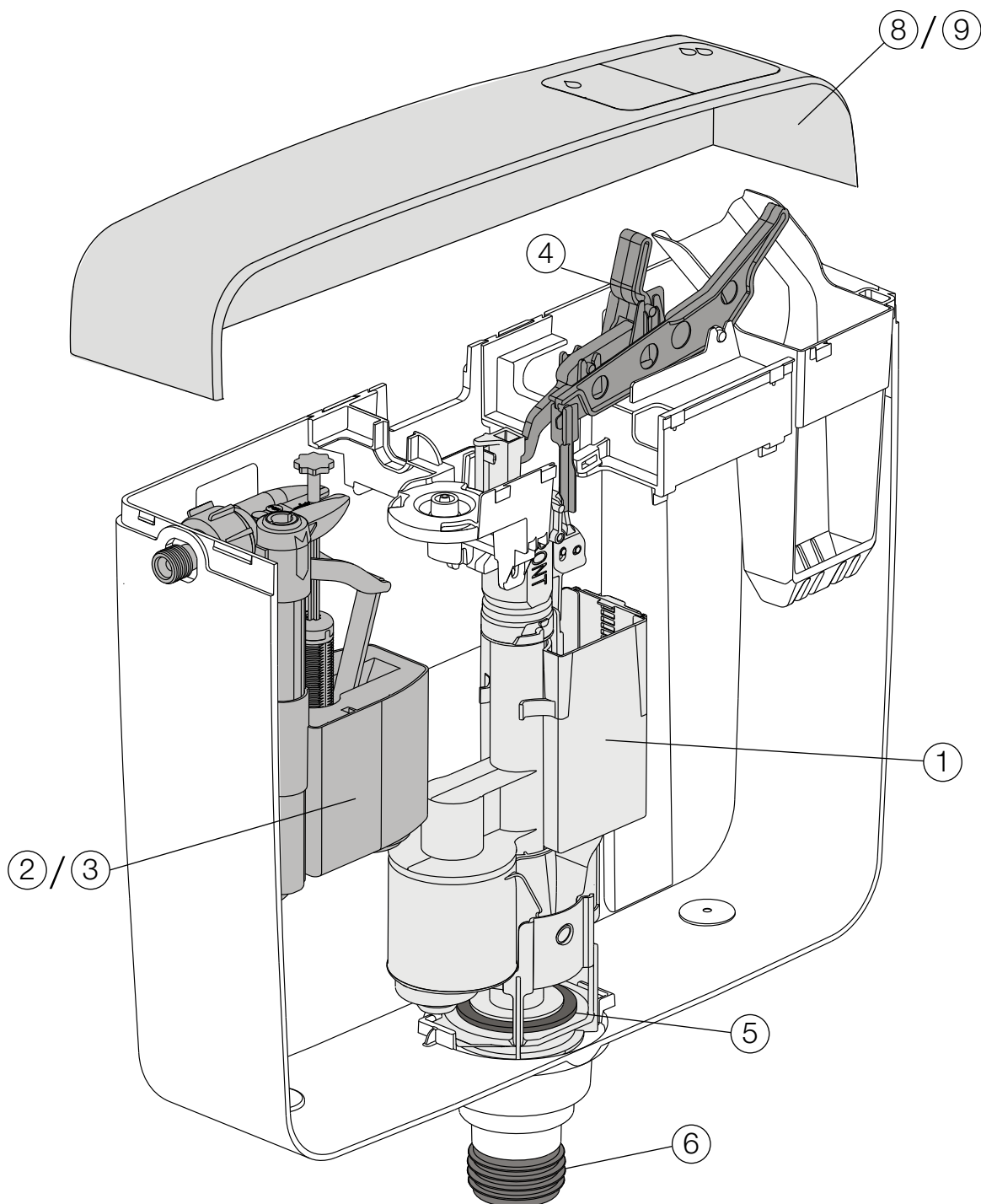

VS0868834



1

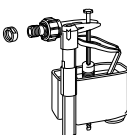
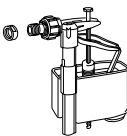
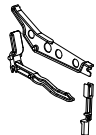
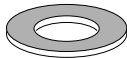

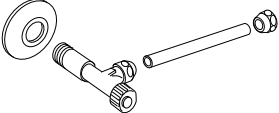
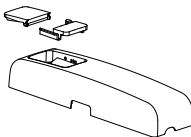
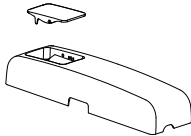
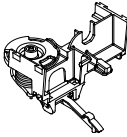
## Ricambi - Spare parts - Pièces de rechange

			COD.	
①		Valvola con piletta Outlet valve with guide Vanne avec regard	VS0817401	1
②		Rubinetto galleggiante 3/8" Float valve 3/8" Robinet flotteur 3/8"	VS0800218	1
③		Rubinetto galleggiante 1/2" Float valve 1/2" Robinet flotteur 1/2"	VS0800219	1
④		Kit leve azionamento meccanico Mechanical flush levers Kit leviers actionnement mécanique	VS0817403	1
⑤		Guarnizione per valvola Seal for outlet valve Joint de mécanisme	VS0866603	10
⑥		Morsetto di uscita Connection seal Joint de cuvette	VS0810521	10
⑦		Kit rubinetto d'arresto Kit stop valve Kit robinet d'arrêt	VS0810522	1
⑧		Coperchio per versione meccanica Lid for mechnic version Couvercle pour version mécanique	VS0817404	1
⑨		Coperchio per versione pneumatica Lid for pneumatic version Couvercle pour version pneumatique	VS0817405	1
⑩		Kit pneumatico Pneumatic kit Kit pneumatique	VS0817410	1
⑪		Tubo flessibile inox con raccordo per alimentazione dal basso 3/8" Stainless steel hose for bottom water connection 3/8" Tuyau flexible inox avec raccord pour alimentation d'en bas 3/8"	VS0810078	1



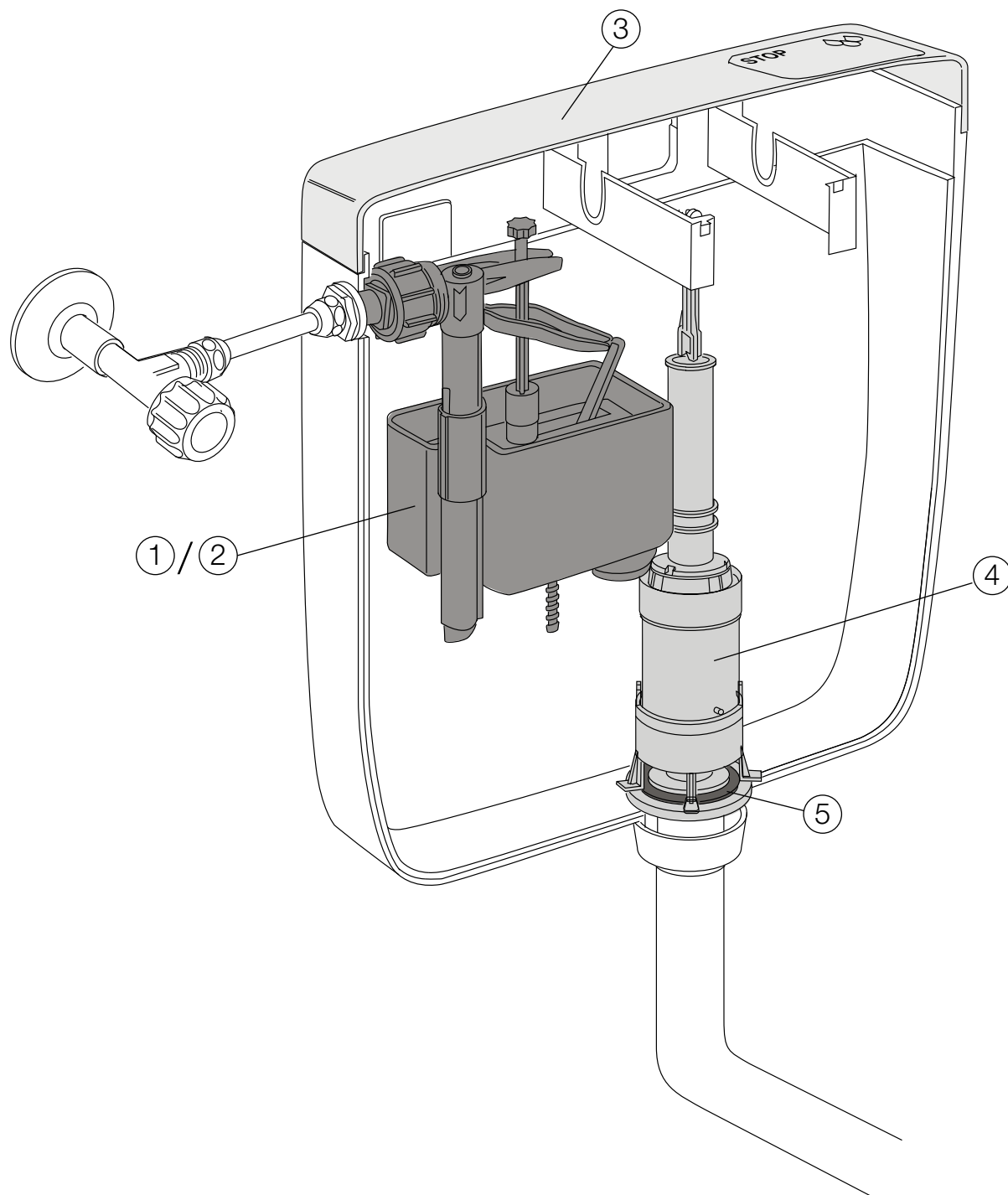



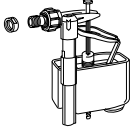
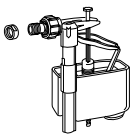
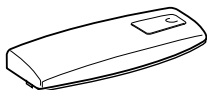
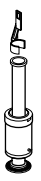
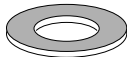

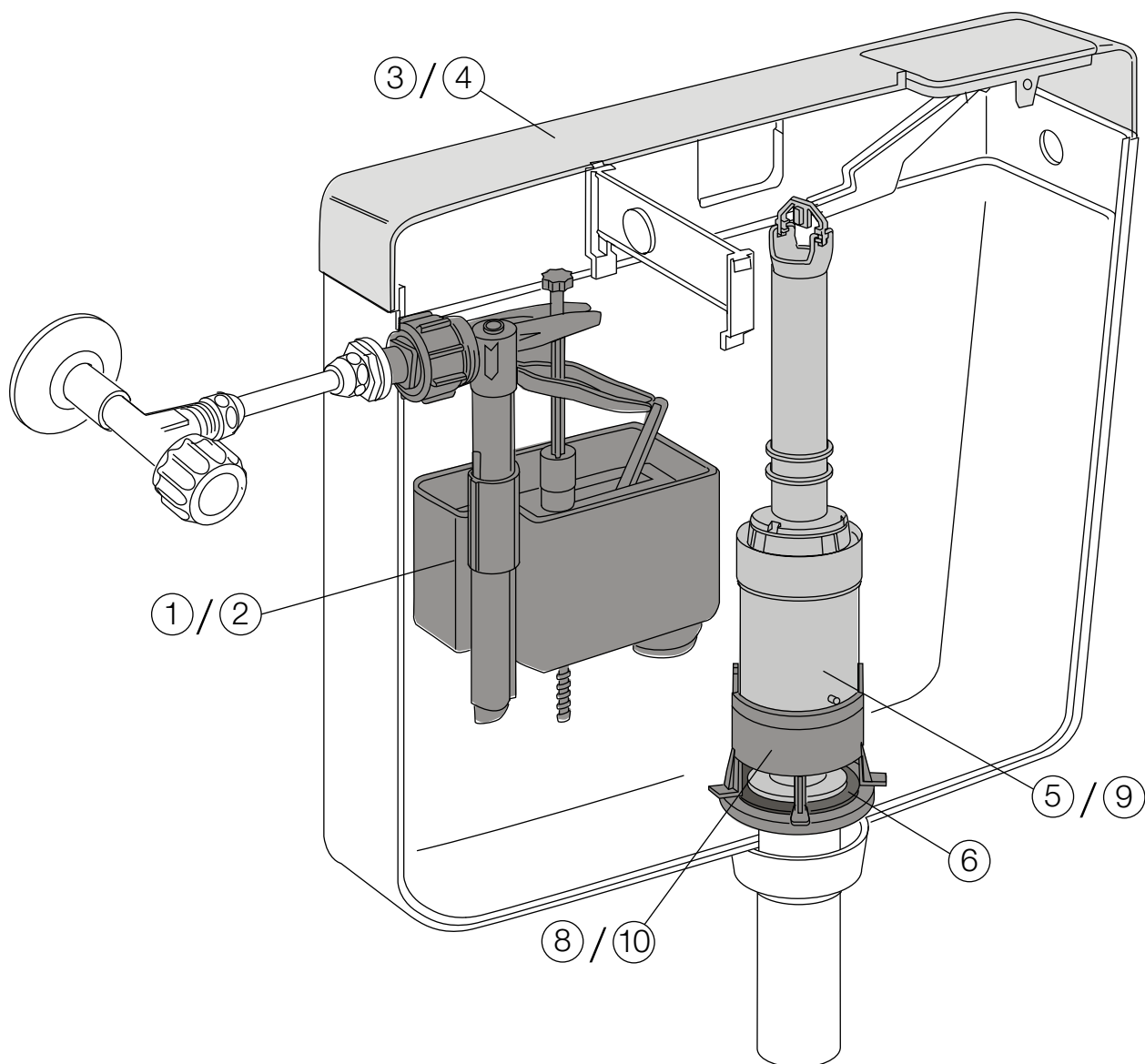
**Ricambi - Spare parts - Pièces de rechange**

			<b>COD.</b>	
①		Rubinetto galleggiante 3/8" Mono <i>3/8" Mono float valve</i> <i>Robinet flotteur 3/8" Mono</i>	VS0800218	1
②		Rubinetto galleggiante 1/2" Mono <i>1/2" Mono float valve</i> <i>Robinet flotteur 1/2" Mono</i>	VS0800219	1
③		Coperchio con pulsante <i>Lid with push button</i> <i>Couvercle avec poussoir</i>	VS0846100	1
④		Valvola di scarico completa di ancorina <i>Outlet valve with anchor</i> <i>Mécanisme avec accroche</i>	VS0810293	1
⑤		Guarnizione per valvola di scarico <i>Washer for flush valve</i> <i>Joint de mécanisme</i>	VS0801017	10

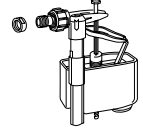
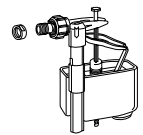
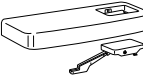
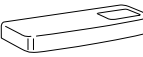

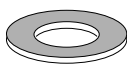
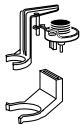

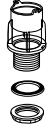
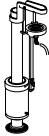

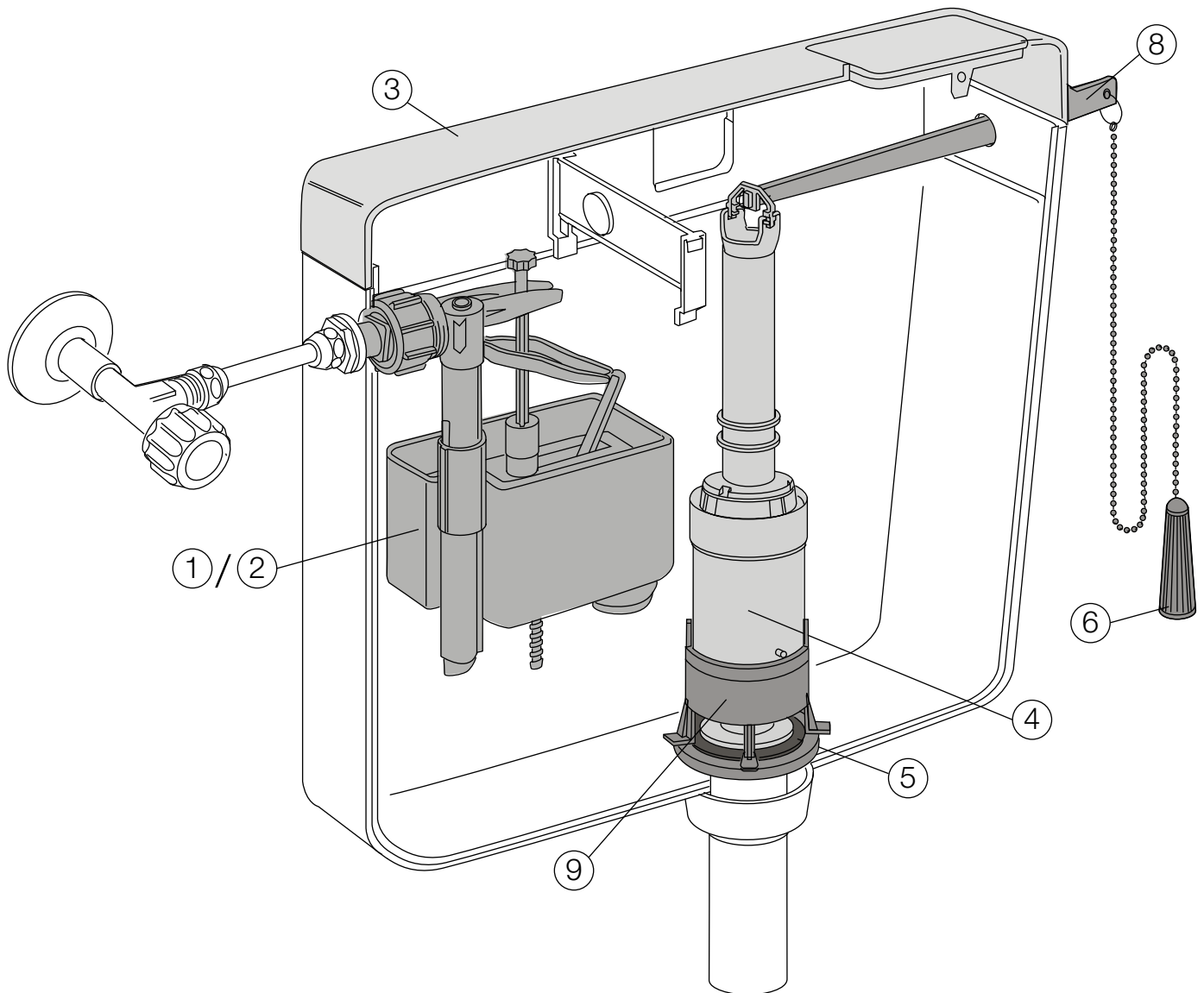

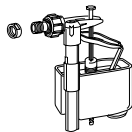
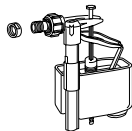

**Ricambi - Spare parts - Pièces de rechange**

			<b>COD.</b>	
①		Rubinetto galleggiante 3/8" mono <i>3/8" mono float valve</i> <i>Robinet flotteur 3/8" mono</i>	VS0800218	1
②		Rubinetto galleggiante 1/2" mono <i>1/2" mono float valve</i> <i>Robinet flotteur 1/2" mono</i>	VS0800219	1
③		Coperchio con pulsante per cassetta Mida <i>Lid with push button for Mida cistern</i> <i>Couvercle avec poussoir pour réservoir Mida</i>	VS0850100	1
④		Coperchio con coperchietto fisso pneu <i>Lid with fixed cap pneu</i> <i>Couvercle fixe pour mécanisme</i>	VS0860050	1
⑤		Valvola di scarico completa di ancorina <i>Flush valve with anchor</i> <i>Mécanisme avec accroche</i>	VS0810291	1
⑥		Guarnizione per valvola di scarico <i>Washer for flush valve</i> <i>Joint de mécanisme</i>	VS0801017	10
⑦		Meccanismo pneumatico applicabile alla valvola di scarico <i>Pneumatic mechanism for flush valve</i> <i>Mécanisme pneumatique à monter sur mécanisme</i>	VS0804505	1
⑧		Piletta a scatto <i>Click-in baskets</i> <i>Siège</i>	VS0810159	1
⑨		Valvola di scarico completa di ancorina dal 1996 al 2000 <i>Flush valve with anchor from 1996 to 2000</i> <i>Mécanisme avec accroche 1996-2000</i>	VS0850021	1
⑩		Piletta con dado e guarnizione dal 1996 al 2000 <i>Basket with nut and seal from 1996 to 2000</i> <i>Siège avec écrou et joint 1996-2000</i>	VS0839081	1
⑪		Valvola di scarico pneumatica dal 1996 al 2000 <i>Pneumatic flush valve from 1996 to 2000</i> <i>Mécanisme pneumatique 1996-2000</i>	VS0804660	1

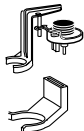

**Ricambi - Spare parts - Pièces de rechange**

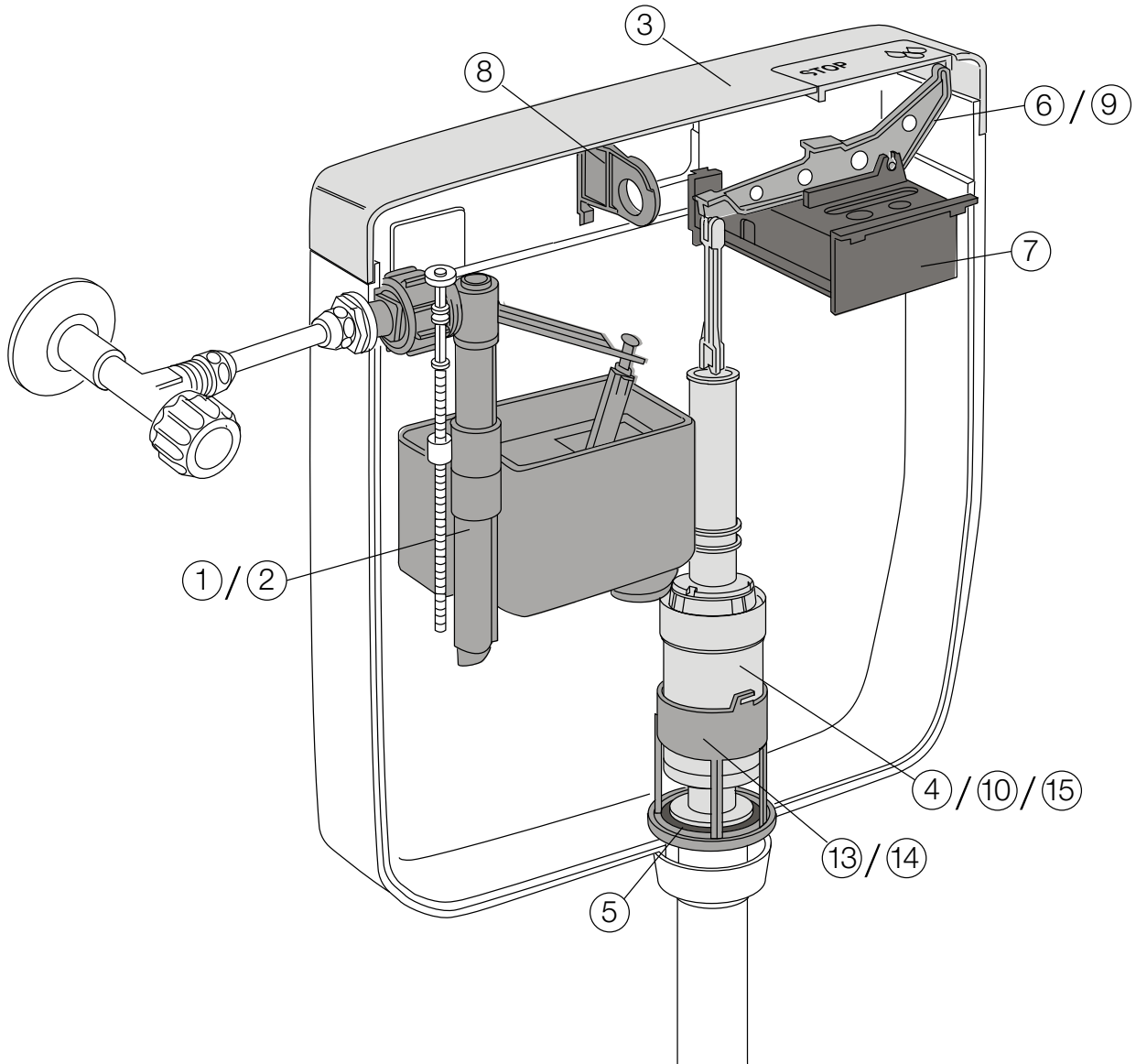

			<b>COD.</b>	
①		Rubinetto galleggiante 3/8" Mono <i>3/8" Mono float valve</i> <i>Robinet flotteur 3/8" mono</i>	VS0800218	1
②		Rubinetto galleggiante 1/2" Mono <i>1/2" Mono float valve</i> <i>Robinet flotteur 1/2" mono</i>	VS0800219	1
③		Coperchio con coperchietto fisso <i>Lid with fixed cap</i> <i>Couvercle fixe pour mécanisme</i>	VS0860050	1
④		Valvola di scarico completa di ancorina dal 2001 al 2015 <i>Flush valve with anchor from 2001 to 2015</i> <i>Mécanisme avec accroche 2001-2015</i>	VS0810291	1
⑤		Guarnizione per valvola di scarico <i>Seal for flush valve</i> <i>Joint de mécanisme</i>	VS0801017	10
⑥		Catenella con maniglia bianca <i>Chain with white handle</i> <i>Chainette avec poignée blanche</i>	VS0850050	1
⑦		Meccanismo pneumatico applicabile alla valvola di scarico dal 2000 al 2015 <i>Pneumatic mechanism for flush valve from 2000 to 2015</i> <i>Mécanisme pneumatique à monter sur mécanisme 2000-2015</i>	VS0804505	1
⑧		Leva di comando <i>Control lever</i> <i>Levier de commande</i>	VS0850022	1
⑨		Piletta con dado e guarnizione dal 1996 al 2000 <i>Basket with nut and seal 1996 to 2000</i> <i>Siège avec écrou et joint pou réservoir attendant 1996-2000</i>	VS0839081	1
⑩		Valvola di scarico completa di ancorina dal 1996 al 2000 <i>Flush valve with anchor from 1996 to 2000</i> <i>Mécanisme avec accroche 1996-2000</i>	VS0850021	1







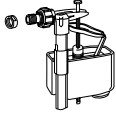



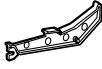
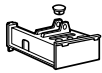

### Ricambi - Spare parts - Pièces de rechange

COD.

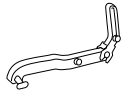

①		Rubinetto galleggiante 3/8" Mono 3/8" Mono float valve Robinet flotteur 3/8" mono	VS0800218	1
②		Rubinetto galleggiante 1/2" Mono 1/2" Mono float valve Robinet flotteur 1/2" mono	VS0800219	1
③		Coperchio cassetta Atlanta con pulsante Lid for Atlanta cistern with push button Couvercle avec poussoir pour réservoir Atlanta	VS0838001 VS0838003 VS0838005-09 13-17-21	1

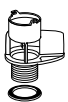
**Ricambi - Spare parts - Pièces de rechange**

			<b>COD.</b>	
④		Valvola di scarico dal 2001 al 2016 <i>Flush valve from 2001 to 2016</i> <i>Mécanisme 2001-2016</i>	VS0810251	1
⑤		Guarnizione valvola di scarico <i>Washer for flush valve</i> <i>Joint de mécanisme</i>	VS0801017	10
⑥		Leva di scarico totale <i>Full flush lever</i> <i>Levier de commande débit total</i>	VS0810157	1
⑦		Blocco centrale porta leva <i>Central block for lever</i> <i>Bloc central porte levier</i>	VS0838591	1
⑧		Squadretta porta rubinetto galleggiante <i>Element for holding float valve</i> <i>Support robinet flotteur</i>	VS0838501	1
⑨		Leva di scarico parziale <i>Half flush lever</i> <i>Levier de commande débit partiel</i>	VS0810166	1
⑩		Valvola di scarico 2 quantità completa di ancorina e kit leve movimento dal 2001 al 2016 <i>Dual flush valve with anchor and kit with lever</i> <i>from 2001 to 2016</i> <i>Vanne d'évacuation 2 quantité avec</i> <i>ancres et kit leviers mouvement de 2001 à 2016</i>	VS0810148	1
⑪		Meccanismo pneumatico Atlanta dal 2001 al 2016 <i>Pneumatic mechanism for Atlanta from 2001 to 2016</i> <i>Mécanisme pneumatique Atlanta 2001-2016</i>	VS0804505	1
⑫		Valvola di scarico pneumatica dal 1994 al 2000 <i>Pneumatic flush valve from 1994 to 2000</i> <i>Mécanisme pneumatique Atlanta 1994-2000</i>	VS0804660	1
⑬		Piletta con dado e guarnizione per cassetta monoblocco dal 1994 al 2000 <i>Basket with nut and seal for close-coupled cistern from 1994 to 2000</i> <i>Siège avec écrou et joint</i> <i>pour réservoir monobloc 1994-2000</i>	VS0839081	1
⑭		Piletta con dado e guarnizione per cassetta a bassa e media posizione dal 1994 al 2000 <i>Basket with nut and seal for low and medium</i> <i>level cistern from 1994 to 2000</i> <i>Siège avec écrou et joint pour réservoir bas mi haut 1994-2000</i>	VS0839088	1
⑮		Valvola di scarico dal 1994 al 2000 <i>Flush valve from 1994 to 2000</i> <i>Mécanisme 1994-2000</i>	VS0810107	1



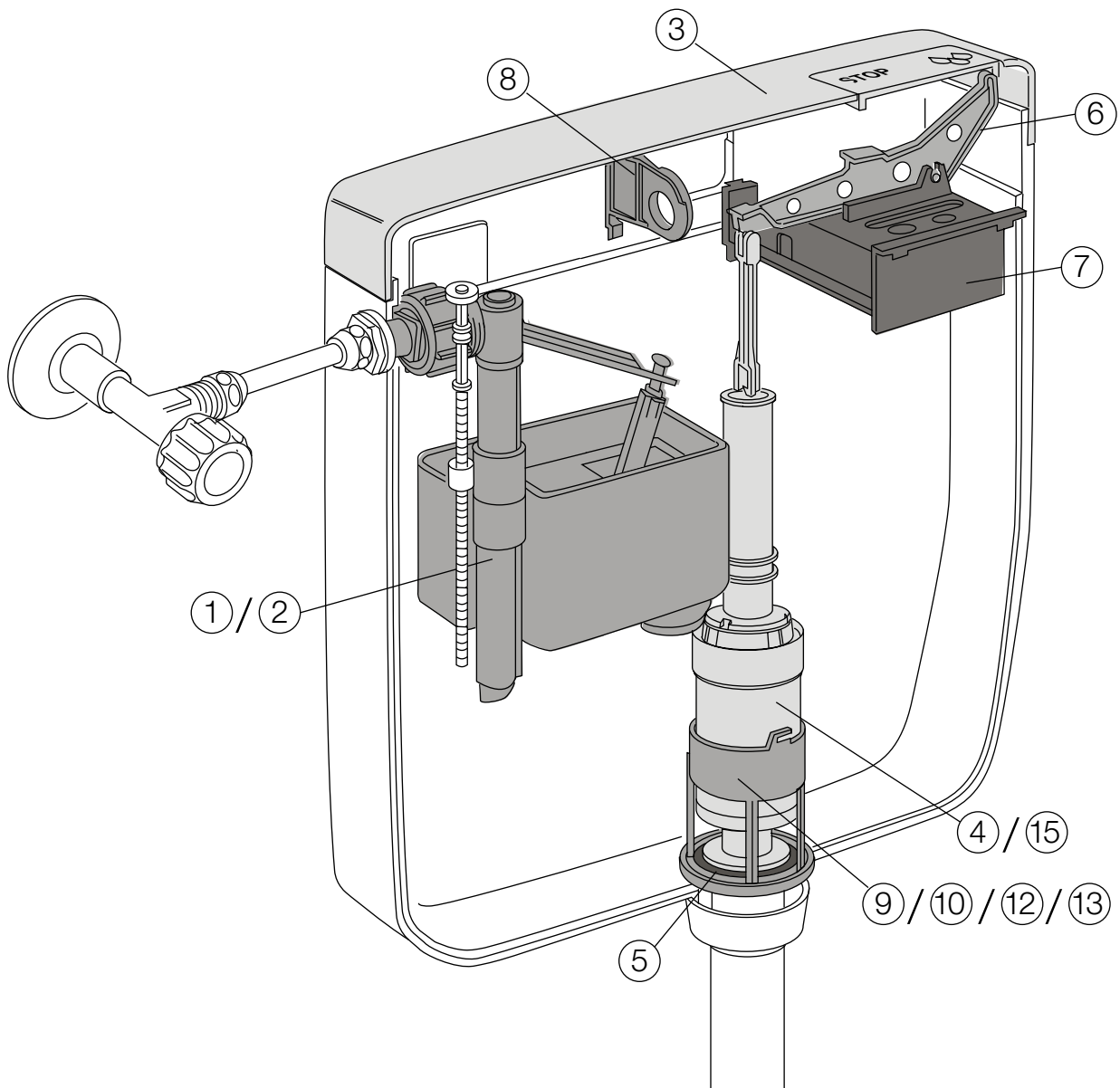









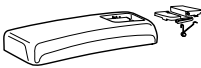

### Ricambi - Spare parts - Pièces de rechange

**COD.**



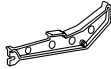
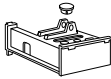

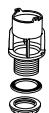
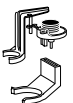
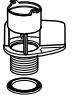
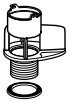
①		Rubinetto galleggiante 3/8" Mono 3/8" Mono float valve Robinet flotteur 3/8" mono	VS0800218	1
②		Rubinetto galleggiante 1/2" Mono 1/2" Mono float valve Robinet flotteur 1/2" mono	VS0800219	1
③		Coperchio cassetta Solea con pulsante Lid for Solea cistern with push button Couvercle avec poussoir pour réservoir Solea	VS0838801 VS0838805-09 13-17-21	1

**Ricambi - Spare parts - Pièces de rechange**

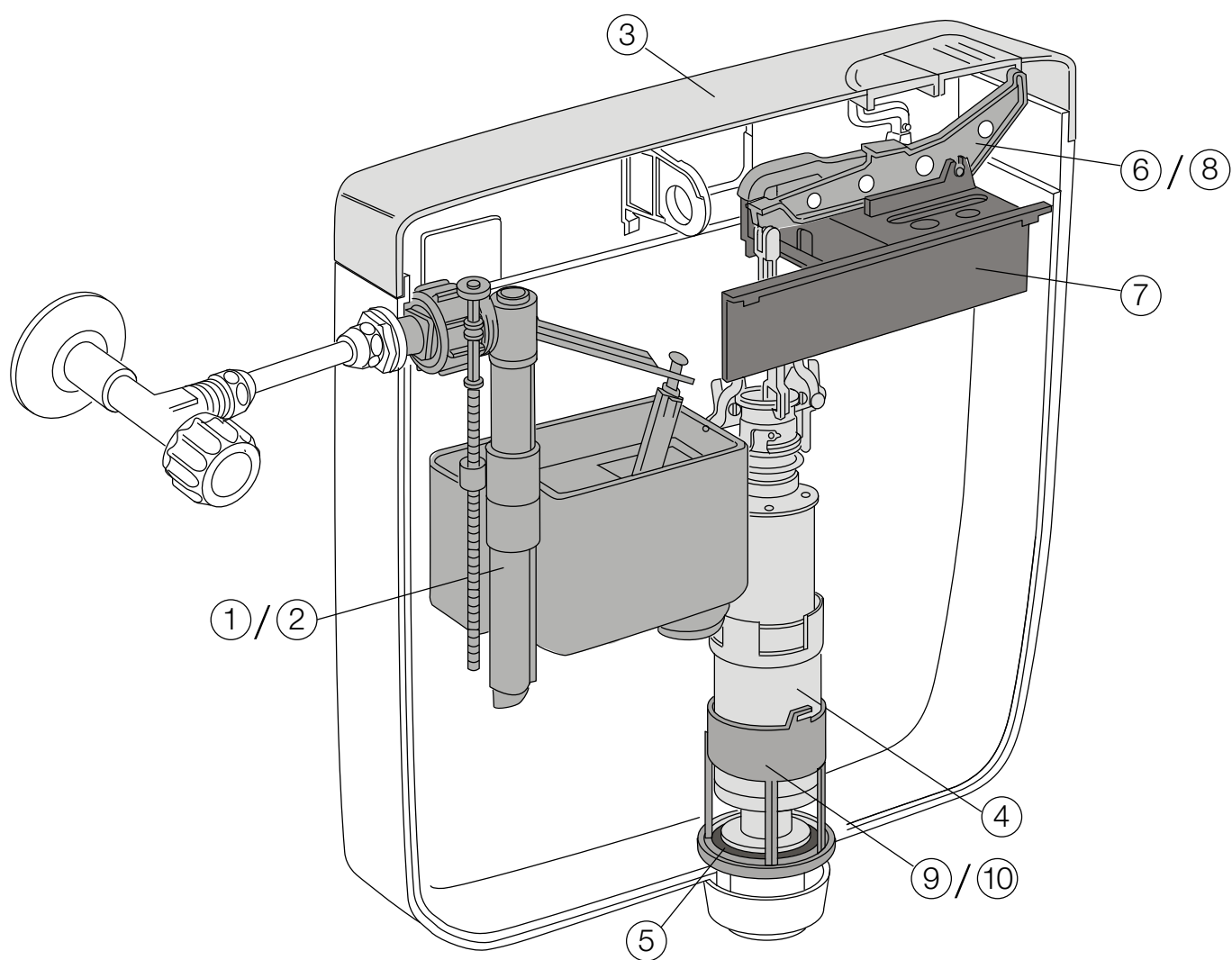
			<b>COD.</b>	
④		Valvola di scarico dal 2001 al 2016 <i>Flush valve from 2001 to 2016</i> <i>Mécanisme 2001-2016</i>	VS0810251	1
⑤		Guarnizione per valvola di scarico <i>Seal for flush valve</i> <i>Joint de mécanisme</i>	VS0801017	10
⑥		Leva <i>Lever</i> <i>Levier</i>	VS0810106	1
⑦		Blocco centrale porta leva <i>Central block for lever</i> <i>Bloc central porte levier</i>	VS0838401	1
⑧		Squadretta porta rubinetto galleggiante <i>Element for holding float valve</i> <i>Support robinet flotteur</i>	VS0838501	1
⑨		Piletta completa di dado e guarnizione per cassetta monoblocco <i>Basket with nut and seal for close-coupled cistern</i> <i>Siège avec écrou et joint pour réservoir monobloc</i>	VS0810258	1
⑩		Piletta completa di dado e guarnizione per cassetta a bassa e media posizione <i>Basket with nut and seal for low-and medium level cistern</i> <i>Siège avec écrou et joint pour réservoir bas mi haut</i>	VS0810261	1
⑪		Meccanismo pneumatico Solea dal 2001 al 2016 <i>Pneumatic mechanism for Solea from 2001 to 2016</i> <i>Mécanisme pneumatique Solea 2001-2016</i>	VS0804505	1
⑫		Piletta con dado e guarnizione per cassetta monoblocco dal 1994 al 2000 <i>Guide with nut and seal for close-coupled cistern from 1994 to 2000</i> <i>Siège avec écrou et joint pour réservoir monobloc 1994-2000</i>	VS0839081	1
⑬		Piletta con dado e guarnizione per cassetta a bassa e media posizione dal 1994 al 2000 <i>Guide with nut and seal for low and medium level cistern from 1994 to 2000</i> <i>Siège avec écrou et joint pour réservoir bas mi haut 1994-2000</i>	VS0839088	1
⑭		Valvola di scarico pneumatica dal 1994 al 2000 <i>Pneumatic outlet valve from 1994 to 2000</i> <i>Mécanisme pneumatique 1994-2000</i>	VS0804660	1
⑮		Valvola di scarico dal 1994 al 2000 <i>Outlet valve from 1994 to 2000</i> <i>Mécanisme 1994-2000</i>	VS0810107	1

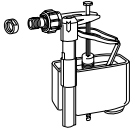
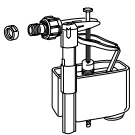
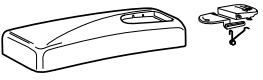

**Ricambi - Spare parts - Pièces de rechange**

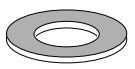
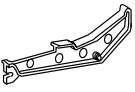
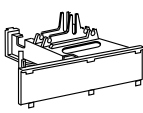
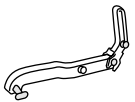
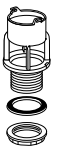
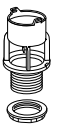
			<b>COD.</b>	
①		Rubinetto galleggiante 3/8" Mono <i>3/8" Mono float valve</i> <i>Robinet flotteur 3/8" mono</i>	VS0800218	1
②		Rubinetto galleggiante 1/2" Mono <i>1/2" Mono float valve</i> <i>Robinet flotteur 1/2" mono</i>	VS0800219	1
③		Coperchio con pulsanti <i>Lid with push buttons</i> <i>Couvercle avec poussoirs</i>	VS0831401	1
④		Valvola di scarico 2 quantità completa di ancorina e kit leve movimento <i>Dual flush valve with anchor and kit with lever</i> <i>Vanne d'évacuation 2 quantité avec ancre et kit leviers mouvement</i>	VS0810148	1
⑤		Guarnizione per valvola di scarico <i>Washer for flush valve</i> <i>Joint de mécanisme</i>	VS0801017	10
⑥		Leva scarico totale <i>Control lever, full flush</i> <i>Levier évacuation totale</i>	VS0810163	1
⑦		Blocco centrale porta leva <i>Central block for lever</i> <i>Bloc central porte levier</i>	VS0838591	1
⑧		Leve scarico parziale <i>Half flush lever</i> <i>Levier évacuation partielle</i>	VS0810164	1
⑨		Piletta completa di dado e guarnizione per cassetta monoblocco <i>Basket with nut and seal for</i> <i>close-coupled cistern</i> <i>Siège avec écrou et joint</i> <i>pour réservoir monobloc</i>	VS0810258	1
⑩		Piletta completa di dado e guarnizione per cassetta a bassa e media posizione <i>Basket with nut and seal for low-and</i> <i>medium level cistern</i> <i>Siège avec écrou et joint pour réservoir</i> <i>bas mi haut</i>	VS0810261	1

Lined writing area with 20 horizontal lines. The top 10 lines are pre-filled with the following icons from left to right: a vertical bar, a swastika, a crescent moon, a flame, a bird, a teardrop, a stylized 'E', a water drop, and a triangle with an 'A' inside. The remaining 10 lines are blank.

# **ACCESSORI E RICAMBI PER PRODUZIONI FINO AL 2015**

*ACCESSORIES AND SPARE PARTS FOR  
PRODUCTION UP TO 2015*

*ACCESSOIRES ET PIÈCES DE RECHANGE  
POUR PRODUITS FINIS EN 2015*

# PLACCHE DI COMANDO CASSETTE FUORI PRODUZIONE

PUSH PLATES OF FLUSH CISTERNS OUT OF PRODUCTION

PLAQUES DE COMMANDE RÉSERVOIRS HORS PRODUCTION

## Placca meccanica doppio scarico

Dual flush push plate, mechanical

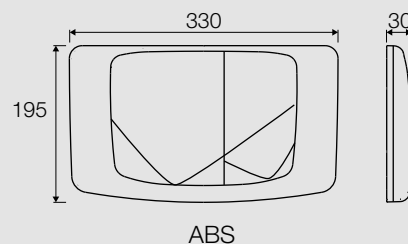

Plaque mecanique double débit



### ANGEL - RIOS

COD.	Colore - Colour - Couleur		
VS0828501	bianco - white - blanc		5
VS0828503 •	champagne		5
VS0828535	cromo lucido - polished chrome - chromé brillant		5
VS0828537	cromo satinato - satin chrome - chromé mat		5
VS0828601	bianco - white - blanc	inviolabile - tamper-proof - inviolable	5
VS0828635	cromo lucido - polished chrome - chromé brillant	inviolabile - tamper-proof - inviolable	5
VS0828637	cromo satinato - satin chrome - chromé mat	inviolabile - tamper-proof - inviolable	5

• Ad esaurimento. - Sell out. - Fin de stock.

 Pz - Pcs	HxLxP	kg	m <sup>3</sup>	 Pz - Pcs	HxLxP	kg	m <sup>3</sup>	 Pz - Pcs	HxLxP	kg	m <sup>3</sup>
1	47x352x200	0,7	0,004	5	210x360x265	3,5	0,02	225	1200x800x1200	167	1,15

## Placca meccanica doppio scarico

Dual flush push plate, mechanical

Plaque mecanique double débit

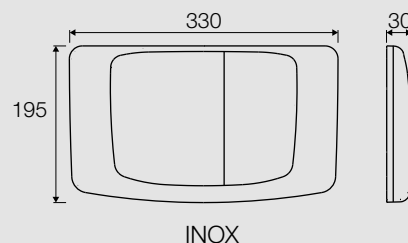

### ANGEL - RIOS

COD.	Colore - Colour - Couleur		
VS0828801	inox - stainless steel - inox	inviolabile - tamper-proof - inviolable	1

 Pz - Pcs	HxLxP	kg	m <sup>3</sup>
1	47x350x200	1,1	0,004

## Placca meccanica singolo scarico - ABS

Single flush push plate,  
mechanical - ABS

Plaque mecanique simple débit

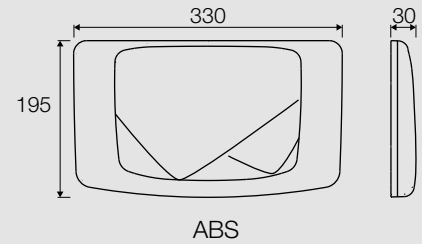

### ANGEL - RIOS

COD.	Colore - Colour - Couleur	
VS0828001	bianco - white	5
VS0828003 •	champagne	5
VS0828005 •	grigio manhattan - manhattan grey - gris manhattan	5
VS0828017 •	visone beige - beige - vison beige	5
VS0828021 •	pergamon	5
VS0828037 •	cromo satinato - satin chrome - chromé mat	5
VS0828137 •	cromo satinato - satin chrome - chromé mat	5
	inviolabile - tamper-proof - inviolable	5

• Ad esaurimento. - Sell out. - Fin de stock.



Pz - Pcs	HxLxP	kg	m <sup>3</sup>
1	47x352x200	0,7	0,004



Pz - Pcs	HxLxP	kg	m <sup>3</sup>
5	210x360x265	3,5	0,021



Pz - Pcs	HxLxP	kg	m <sup>3</sup>
225	1200x800x1200	167	1,15

## Placca meccanica singolo scarico

Single flush push  
plate, mechanical

Plaque mecanique simple débit

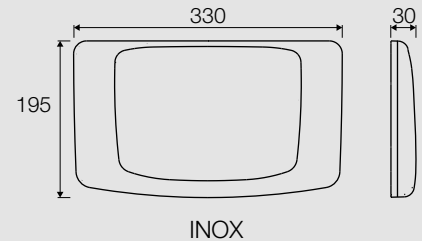

### ANGEL - RIOS

COD.	Colore - Colour - Couleur	
VS0828301 •	inox - stainless steel - inox	1
	inviolabile - tamper-proof - inviolable	1

• Ad esaurimento. - Sell out. - Fin de stock.



Pz - Pcs	HxLxP	kg	m <sup>3</sup>
1	47x350x200	1,1	0,004



**ACCESSORI E RICAMBI PER PRODUZIONI FINO AL 2015**

ACCESSORIES AND SPARE PARTS FOR PRODUCTION UP 2015  
ACCESSOIRES ET PIÈCES DE RECHANGE POUR PRODUITS FINIS EN 2015

CASSETTE FLUSHCISTERNS RESERVOIRDECHASSE

**Placca ispezione**

Access plate  
Plaque d'inspection



**ANGEL - RIOS**

COD.	Colore - Colour - Couleur	
VS0822201	inox - stainless steel	1

	Pz - Pcs	HxLxP	kg	m <sup>3</sup>
	1	47x350x200	0,86	0,004

**Placca meccanica singolo scarico**

Single flush push plate, mechanical  
Plaque mecanique simple débit

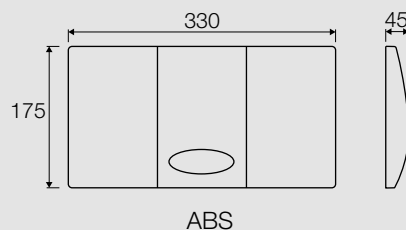

**ANGEL - RIOS**

COD.	Colore - Colour - Couleur		
VS0822001	bianco - white - blanc	5	
VS0822003 •	champagne	5	
VS0822005 •	grigio manhattan - manhattan grey - gris manhattan	5	
VS0822017 •	visone beige - beige - vison beige	5	
VS0822035 •	cromo lucido - polished chrome - chromé brillant	5	
VS0822038 •	dorato - gold finish - doré	5	
VS0822301	bianco - white - blanc	inviolabile - tamper-proof - inviolable	5
VS0822337 •	cromo satinato - satin chrome - chromé mat	inviolabile - tamper-proof - inviolable	5

• Ad esaurimento. - Sell out. - Fin de stock.

	Pz - Pcs	HxLxP	kg	m <sup>3</sup>
	1	47x352x200	0,7	0,004

	Pz - Pcs	HxLxP	kg	m <sup>3</sup>
	5	210x360x265	3,5	0,02

	Pz - Pcs	HxLxP	kg	m <sup>3</sup>
	225	1200x800x1200	167	1,15

## Placca ispezione

Access plate

Plaque d'inspection

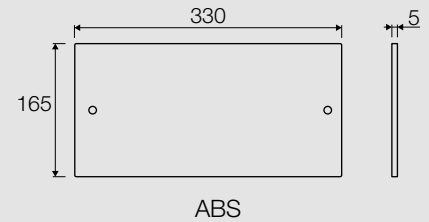

### ANGEL - RIOS

#### COD.

#### Colore - Colour - Couleur

COD.	Colore - Colour - Couleur	
VS0804501	bianco - white - blanc	1
VS0804535	cromo lucido - polished chrome - chromé brillant	1
VS0804537	cromo satinato - satin chrome - chromé mat	1



Pz - Pcs	HxLxP	kg	m <sup>3</sup>
1	20x310x175	0,24	0,001

## Placca meccanica singolo scarico

Single flush push  
plate, mechanical

Plaque mecanique simple débit

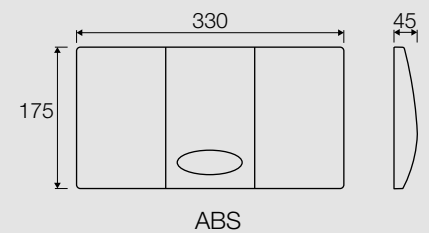

### MEDUSA

#### COD.

#### Colore - Colour - Couleur

COD.	Colore - Colour - Couleur	
VS0804001	bianco - white - blanc	5
VS0804003 •	champagne	5
VS0804005 •	grigio manhattan - manhattan grey - gris manhattan	5
VS0804017 •	visone beige - beige - vison beige	5
VS0804021 •	pergamon	5
VS0804035	cromo lucido - polished chrome - chromé brillant	5
VS0804037 •	cromo satinato - satin chrome - chromé mat	5
VS0804038 •	dorato - gold finish - doré	5

• Ad esaurimento. - Sell out. - Fin de stock.



Pz - Pcs	HxLxP	kg	m <sup>3</sup>
1	47x352x200	0,7	0,004



Pz - Pcs	HxLxP	kg	m <sup>3</sup>
5	210x360x265	3,5	0,02



Pz - Pcs	HxLxP	kg	m <sup>3</sup>
225	1200x800x1200	167	1,15

**ACCESSORI E RICAMBI PER PRODUZIONI FINO AL 2015**ACCESSORIES AND SPARE PARTS FOR PRODUCTION UP 2015  
ACCESSOIRES ET PIÈCES DE RECHANGE POUR PRODUITS FINIS EN 2015



**Placca ispezione**

Access plate

Plaque d'inspection



ABS

**MEDUSA****COD.****Colore - Colour - Couleur**

VS0804501	bianco - white - blanc	1
VS0804535	cromo lucido - polished chrome - chromé brillant	1
VS0804537	cromo satinato - satin chrome - chromé mat	1



Pz - Pcs	HxLxP	kg	m <sup>3</sup>
1	20x310x175	0,24	0,001

**Placca ispezione**

Access plate

Plaque d'inspection

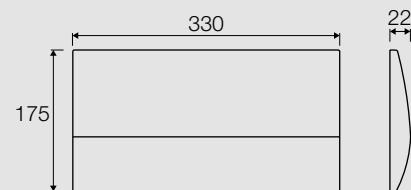

INOX

**MEDUSA****COD.****Colore - Colour - Couleur**

VS0822201	inox - stainless steel - inox	1
-----------	-------------------------------	---



Pz - Pcs	HxLxP	kg	m <sup>3</sup>
1	47x350x200	0,86	0,004

**Placca di comando 6/4 litri + stop meccanica**

*Mechanical push plate  
6/4 litres + stop*

*Placca di comando 6/4 litri + stop meccanica*

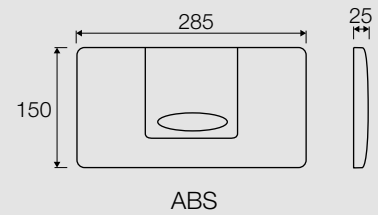

**EGEA**

<b>COD.</b>	<b>Colore - Colour - Couleur</b>		
VS0823401	bianco - white - blanc		5
VS0823435	cromo lucido - polished chrome - chromé brillant		5
VS0823437	cromo satinato - satin chrome - chromé mat		5
VS0823438 •	dorato - gold finish - doré		5
VS0823201	bianco - white - blanc	inviolabile - tamper-proof - inviolable	5
VS0823235	cromo lucido - polished chrome - chromé brillant	inviolabile - tamper-proof - inviolable	5

• Ad esaurimento. - Sell out. - Fin de stock.



<b>Pz - Pcs</b>	<b>HxLxP</b>	<b>kg</b>	<b>m³</b>
1	47x352x200	0,54	0,004



<b>Pz - Pcs</b>	<b>HxLxP</b>	<b>kg</b>	<b>m³</b>
5	210x360x265	2,7	0,02



<b>Pz - Pcs</b>	<b>HxLxP</b>	<b>kg</b>	<b>m³</b>
225	1200x800x1200	130	1,15

**Placca ispezione**

*Access plate*

*Plaque d'inspection*

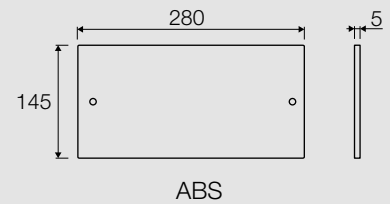

**EGEA**

<b>COD.</b>	<b>Colore - Colour - Couleur</b>		
VS0823801	bianco - white - blanc		1
VS0823835 •	cromo lucido - polished chrome - chromé brillant		1
VS0823837 •	cromo satinato - satin chrome - chromé mat		1
VS0823838 •	dorato - gold finish - doré		1

• Ad esaurimento. - Sell out. - Fin de stock.



<b>Pz - Pcs</b>	<b>HxLxP</b>	<b>kg</b>	<b>m³</b>
1	20x310x175	0,2	0,001

**ACCESSORI E RICAMBI PER PRODUZIONI FINO AL 2015**

ACCESSORIES AND SPARE PARTS FOR PRODUCTION UP 2015

ACCESSOIRES ET PIÈCES DE RECHANGE POUR PRODUITS FINIS EN 2015

CASSETTE FLUSHCISTERNES RESERVOIRDECHASSE

**Placca ispezione**

Access plate

Plaque d'inspection

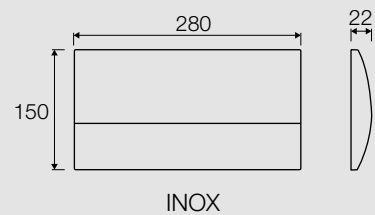

EGEA

**COD.****Colore - Colour - Couleur**

VS0823900 •

inox - stainless steel - inox

1

• Ad esaurimento. - Sell out. - Fin de stock.



Pz - Pcs	HxLxP	kg	m <sup>3</sup>
1	50x295x165	0,63	0,002

# PLACCHE DI COMANDO SINGOLO SCARICO

SINGLE FLUSH PUSH PLATES

PLAQUE DE COMMANDE ÉVACUATION SIMPLE

## Placca pneumatica singolo scarico

Single flush pneumatic push plat

Plaque pneumatique simple débit

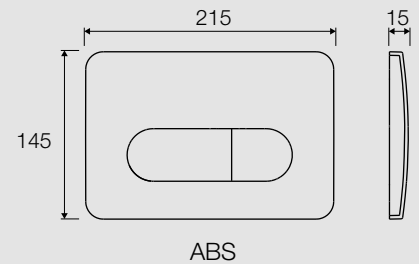



### TROPEA3 - CUBIK - EVOLUT - SPACE

COD.	Colore - Colour - Couleur	
VS0871003 •	champagne	5
VS0871017 •	visone beige - beige - vison beige	5

• Ad esaurimento. - Sell out. - Fin de stock.

	Pz - Pcs	HxLxP	kg	m <sup>3</sup>
	1	90x255x160	0,5	0,004

	Pz - Pcs	HxLxP	kg	m <sup>3</sup>
	5	175x465x265	2,7	0,02

	Pz - Pcs	HxLxP	kg	m <sup>3</sup>
	180			95

## Placca pneumatica singolo scarico

Single flush pneumatic buttons

Plaque pneumatique simple débit

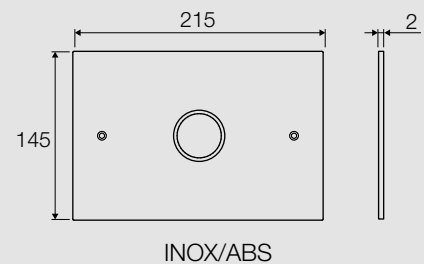

### TROPEA3 - CUBIK - EVOLUT - SPACE

COD.	Colore - Colour - Couleur	
VS0871637 •	inox satinato - satin stainless steel - inox mat	1

• Ad esaurimento. - Sell out. - Fin de stock.

	Pz - Pcs	HxLxP	kg	m <sup>3</sup>
	1	90x255x160	0,8	0,004

**Placca meccanica  
singolo scarico**

Single flush push  
plate, mechanical

Plaque mecanique simple débit

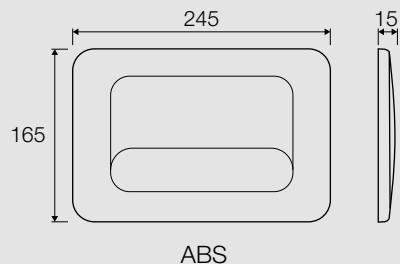

**WINNER - TROPEA2**

<b>COD.</b>	<b>Colore - Colour - Couleur</b>	
VS0870001 •	bianco - white - blanc	5
VS0870035 •	cromo lucido - polished chrome - chromé brillant	5
VS0870037 •	cromo satinato - satin chrome - chromé mat	5

• Ad esaurimento. - Sell out. - Fin de stock.

	<b>Pz - Pcs</b>	<b>HxLxP</b>	<b>kg</b>	<b>m<sup>3</sup></b>		<b>Pz - Pcs</b>	<b>HxLxP</b>	<b>kg</b>	<b>m<sup>3</sup></b>		<b>Pz - Pcs</b>	<b>HxLxP</b>	<b>kg</b>	<b>m<sup>3</sup></b>
	1	48x270x180	0,5	0,002		5	195x275x280	2,5	0,015		250	1130x800x1200	133	1,08

**Placca meccanica  
singolo scarico**

Single flush push  
plate, mechanical

Plaque mecanique simple débit

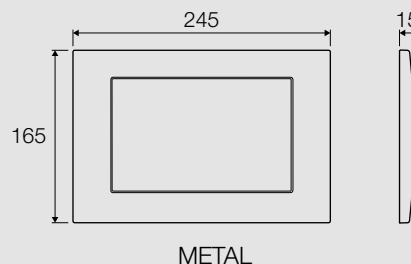

**WINNER - TROPEA2**

<b>COD.</b>	<b>Colore - Colour - Couleur</b>	
VS0870301 •	bianco - white - blanc	5
VS0870337 •	cromo satinato - satin chrome - chromé mat	5

• Ad esaurimento. - Sell out. - Fin de stock.

	<b>Pz - Pcs</b>	<b>HxLxP</b>	<b>kg</b>	<b>m<sup>3</sup></b>		<b>Pz - Pcs</b>	<b>HxLxP</b>	<b>kg</b>	<b>m<sup>3</sup></b>
	1	48x270x180	1,1	0,002		5	195x275x280	5,5	0,015

**Placca pneumatica  
singolo scarico**

*Single flush pneumatic buttons*

*Plaque pneumatique  
simple débit*

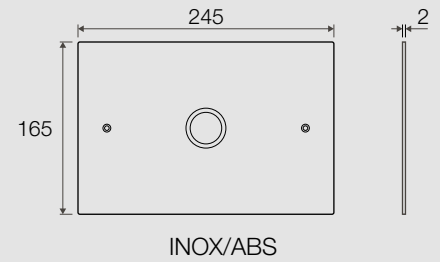

WINNER - TROPEA2

**COD.**

**Colore - Colour - Couleur**



VS0870637 •

inox satinato - *satin stainless steel* - *inox mat*

1

• Ad esaurimento. - *Sell out.* - *Fin de stock.*



Pz - Pcs	HxLxP	kg	m <sup>3</sup>
1	110x265x180	0,9	0,005



# COMANDI PNEUMATICI NON INGOMBRO

## SPACE-SAVING PNEUMATIC ACTUATORS

### COMMANDES PNEUMATIQUES FAIBLE ENCOMBREMENT

#### Pulsanti non ingombro 1/2 scarico e scarico totale

1/2 flush and total flush space saving buttons

Boutons poussoirs faible encombrement évacuation partielle et totale



#### 1/2 scarico - 1/2 flush - 1/2 évacuation

COD.	Colore - Colour - Couleur	
VS0802935	cromo lucido - polished chrome - chromé brillant	1
VS0802937	cromo satinato - satin chrome - chromé mat	1

#### Scarico totale - Total flush - Évacuation totale

COD.	Colore - Colour - Couleur	
VS0802535	cromo lucido - polished chrome - chromé brillant	1
VS0802537	cromo satinato - satin chrome - chromé mat	1

Non comprensivo del kit tubi di collegamento pneumatico. - The kit with pneumatic connection hoses is not included in delivery scope. - Sans le kit tuyaux de raccordement pneumatique. (VS0872204)

	Pz - Pcs	HxLxP	kg	m <sup>3</sup>
	1	110x110x125	0,2	0,0015

#### Comando non ingombro con placca in metallo singolo scarico

Space-saving actuators with metal plate for single volume flush

Bouton poussoir faible encombrement avec plaque métallique évacuation totale

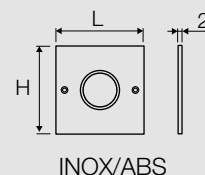

#### a murare - in-wall - A encaster

COD.	Colore - Colour - Couleur	SxLxH	
VS0872335	cromo lucido - polished chrome - chromé brillant	2x100x100	1
VS0872337	cromo satinato - satin chrome - chromé mat	2x100x100	1

#### Per cartongesso - For plasterboard - Pour plaque de plâtre

COD.	Colore - Colour - Couleur	SxLxH	
VS0802835	cromo lucido - polished chrome - chromé brillant	2x85x85	1
VS0802837	cromo satinato - satin chrome - chromé mat	2x85x85	1

Non comprensivo del kit tubi di collegamento pneumatico. - The kit with pneumatic connection hoses is not included in delivery scope. - Sans le kit tuyaux de raccordement pneumatique. (VS0872204)

	Pz - Pcs	HxLxP	kg	m <sup>3</sup>
	1	110x110x125	0,32	0,0015

**ACCESSORI PER TROPEA2, WINNER, CUBIK, EVOLUT**  
*ACCESSORIES FOR TROPEA2, WINNER, CUBIK, EVOLUT*  
*ACCESSOIRES POUR TROPEA2, WINNER, CUBIK, EVOLUT*

**Raccordo gomito  
 flangiato quadro**

*Square flanged elbow*  
*Raccord coudé à bride*

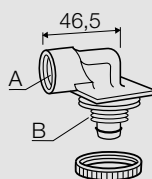



<b>COD.</b>	<b>A</b>	<b>B</b>	
VS0868301 •	G1/2" F	G3/8" F	1

• Ad esaurimento. - Sell out. - Fin de stock.

**Rubinetto d'arresto**

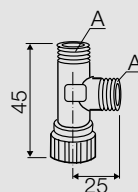
*Stop valve*  
*Robinet d'arrêt*



<b>COD.</b>	<b>A</b>	
VS0868310 •	G3/8" M	10

• Ad esaurimento. - Sell out. - Fin de stock.

**ACCESSORI PER CORALLO2**

*ACCESSORIES FOR CORALLO2*  
*ACCESSOIRES POUR CORALLO2*

**CORALLO2  
 Allacciamento  
 posteriore kit rubinetto**

*Inlet valve kit - rear connection*  
*Raccordement postérieur  
 kit robinet*

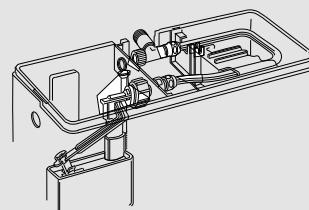
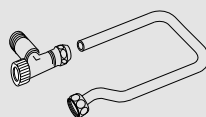

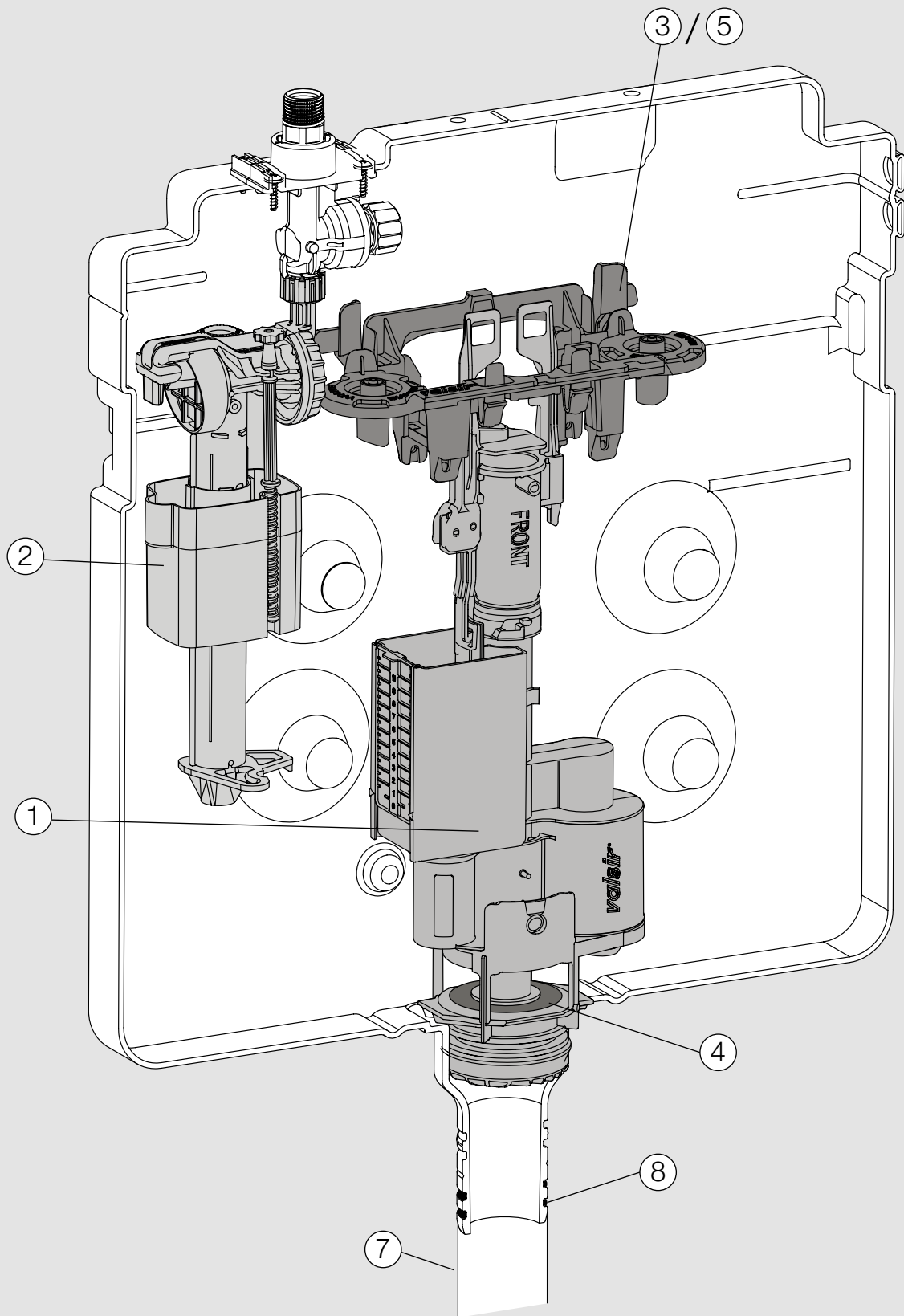

<b>COD.</b>	
VS0810186	1



2012-2015

COD.

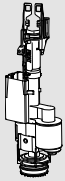
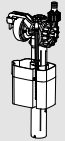
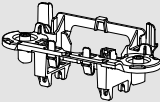
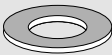
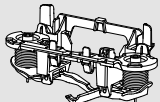
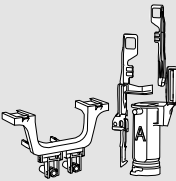
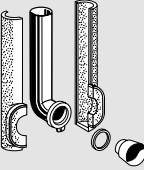



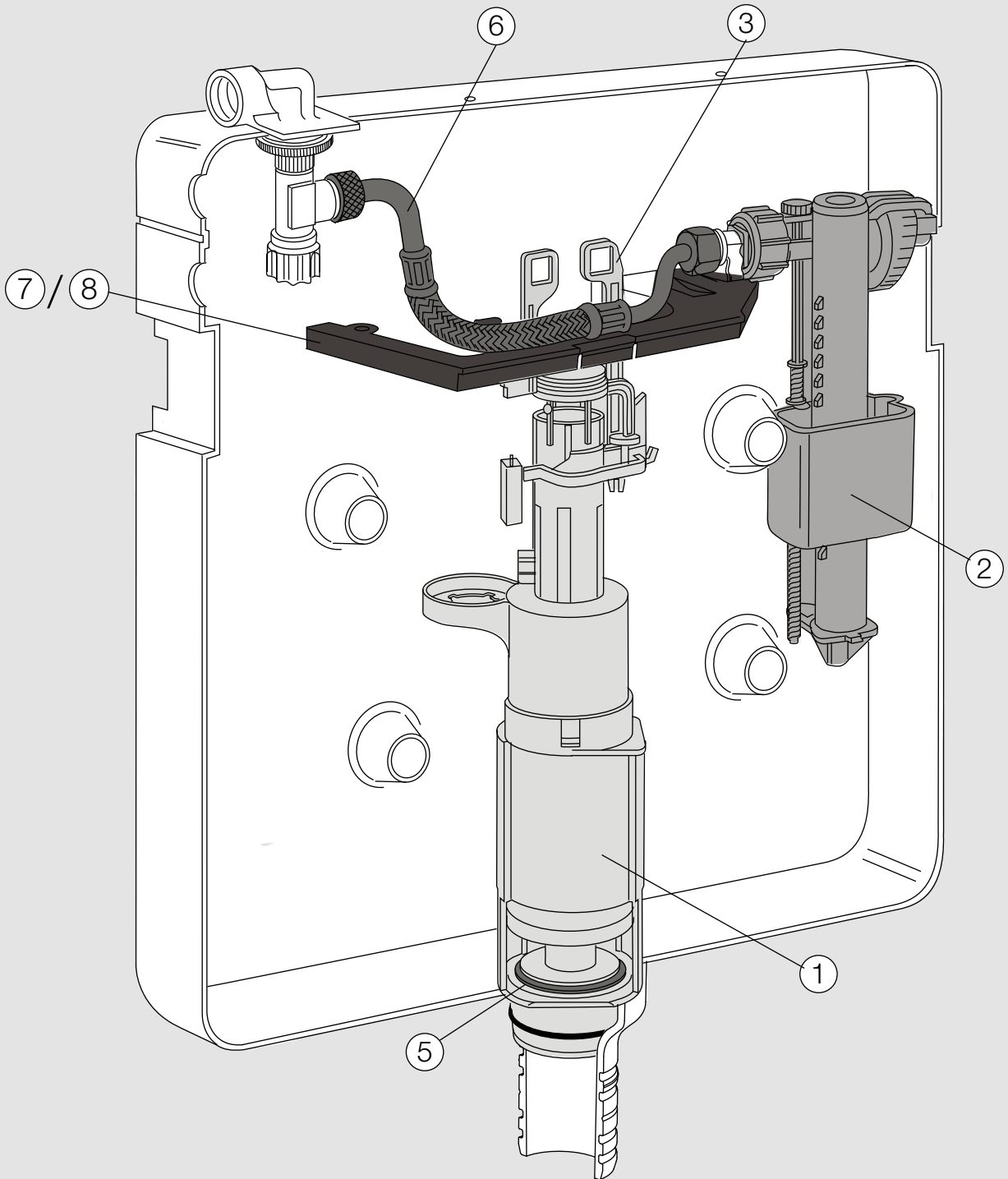





①		Valvola Tropea3 meccanica <i>Tropea3 mechanical valve</i> <i>Vanne pour Tropea3 mécanique</i>	VS0866690	1
②		Rubinetto galleggiante Compact <i>Compact float valve</i> <i>Robinet flotteur Compact</i>	VS0866693	1
③		Blocco centrale <i>Central block</i> <i>Bloc central</i>	VS0866694	1
④		Guarnizione per valvola <i>Washer for outlet valve</i> <i>Joint de mécanisme</i>	VS0866603	10
⑤		Kit trasformazione da meccanico a pneumatico <i>Mechanical to pneumatic conversion kit</i> <i>Kit de commutation de mécanique à pneumatique</i>	VS0866692	1
⑥		Kit trasformazione da pneumatico a meccanico <i>Pneumatic to mechanical conversion kit</i> <i>Kit de commutation de pneumatique à mécanique</i>	VS0866696	1
<b>Set completo ricambi</b> <b>Complete set spare parts - Set completo ricambi (1+2+3+4+5+6)</b>			<b>VS0866699</b>	<b>1</b>
⑦		Kit tubo di risciacquo per Tropea3 <i>Flush pipe kit for Tropea3</i> <i>Kit tuyau de rinçage pour Tropea3</i>	VS0866580	1
⑧		O-ring per bocchettone (2 pz.) <i>O-ring for flush pipe (2 pcs)</i> <i>Joint torique pour embout (2 pcs)</i>	VS0820163	1
⑨		Guarnizione a due labbra per tubo <i>2-lip seal for pipe</i> <i>Joint en deux lèvres pour tuyau</i>	VS0820119	1

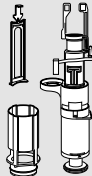
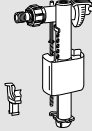
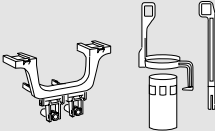

2004-2012

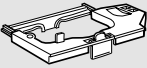
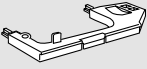
COD.





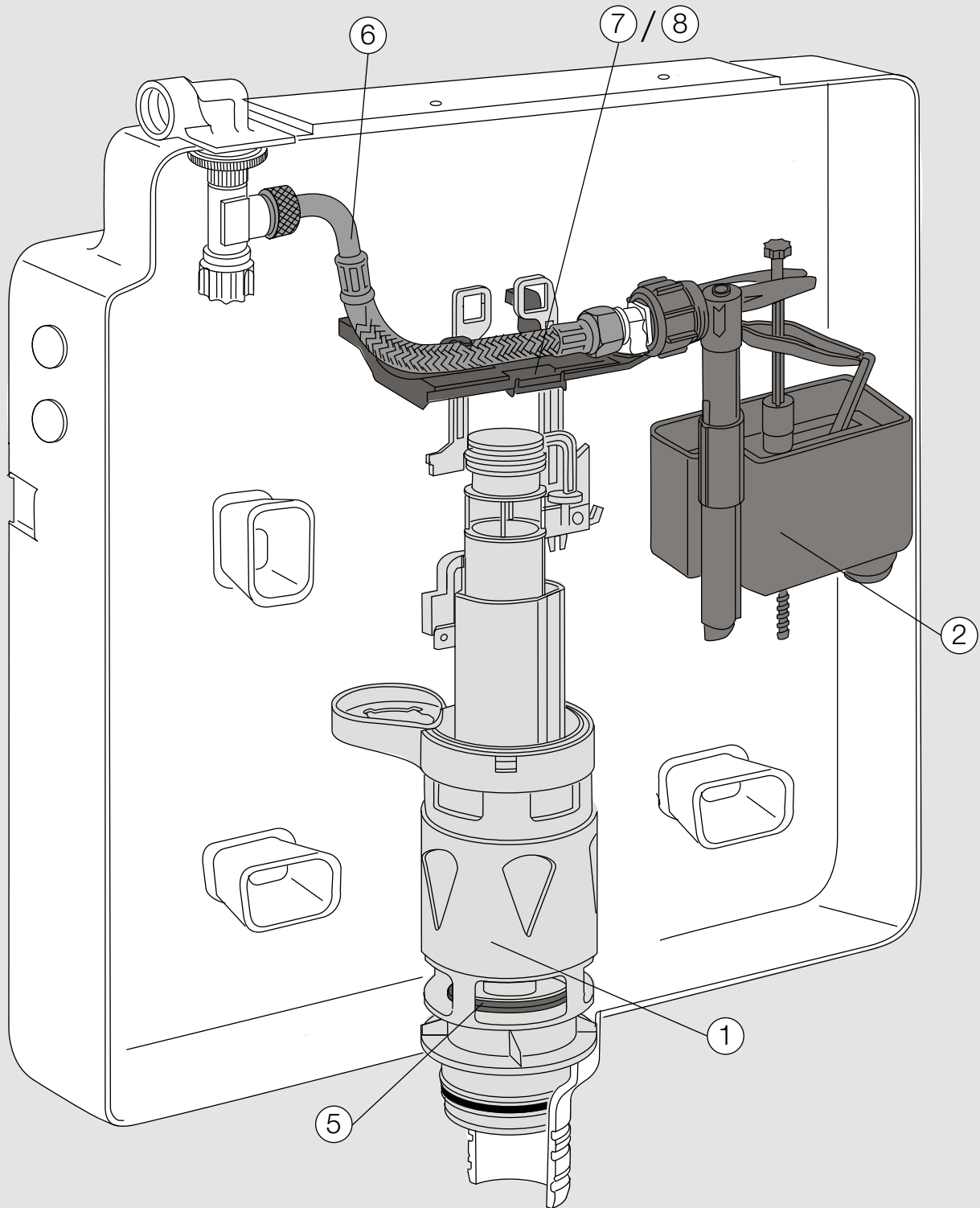





①		<p>Kit valvola dal 2004 al 2012  <i>Valve kit from 2004 to 2012</i>  <i>Kit vanne de 2004 à 2012</i></p>	VS0866801	1
②		<p>Kit galleggiante dal 2004 al 2012  <i>Float valve kit from 2004 to 2012</i>  <i>Kit flotteur de 2004 à 2012</i></p>	VS0866805	1
③		<p>Kit trasformazione da pneumatico a meccanico  <i>Pneumatic to mechanical conversion kit</i>  <i>Kit de commutation de pneumatique à mécanique</i></p>	VS0866803	1
④		<p>Kit trasformazione da meccanico a pneumatico  <i>Mechanical to pneumatic conversion kit</i>  <i>Kit de commutation de mécanique à pneumatique</i></p>	VS0866163	1
<p><b>Set completo ricambi</b>  <b>Complete set spare parts - Jeu complet de pièces de rechange (1+2+3+4)</b></p>			VS0866811	1
⑤		<p>Guarnizione per valvola  <i>Washer for outlet valve</i>  <i>Joint pour vanne</i></p>	VS0801017	10
⑥		<p>Tubo flessibile 3/8"x3/8" Tropea dal 2004 al 2012  <i>Flexible hose 3/8"x3/8" Tropea from 2004 to 2012</i>  <i>Tuyau flexible 3/8"x3/8" Tropea de 2004 à 2012</i></p>	VS0866118	1
⑦		<p>Blocco centrale dal 2008 al 2012  <i>Central block from 2008 to 2012</i>  <i>Bloc central de 2008 à 2012</i></p>	VS0866116	1
⑧		<p>Blocco centrale dal 2004 al 2007  <i>Central block from 2004 to 2007</i>  <i>Bloc central de 2004 à 2007</i></p>	VS0866112	1
⑨		<p>Gancio estrazione piletta  <i>Hook for guide removal</i>  <i>Crochet extraction regard</i></p>	VS0805153	1
⑩		<p>Gancio blocca galleggiante  <i>Hook for securing float valve</i>  <i>Crochet blocage flotteur</i></p>	VS0820111	1
⑪		<p>Guarnizione a due labbra per tubo  <i>2-lip seal for pipe</i>  <i>Joint en deux lèvres pour tuyau</i></p>	VS0820119	1

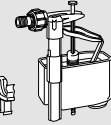

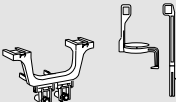
2004-2016

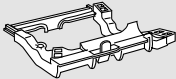
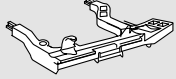
COD.

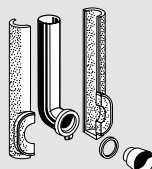

①		<p>Kit valvola dal 2004 al 2016  <i>Valve kit from 2004 to 2016</i>  <i>Kit vanne de 2004 à 2016</i></p>	VS0863851	1
②		<p>Kit galleggiante dal 2004 al 2016  <i>Float valve kit from 2004 to 2016</i>  <i>Kit flotteur de 2004 à 2016</i></p>	VS0863855	1
③		<p>Kit trasformazione da meccanico a pneumatico  <i>Mechanical to pneumatic conversion kit</i>  <i>Kit de commutation de mécanique à pneumatique</i></p>	VS0863160	1
④		<p>Kit trasformazione da pneumatico a meccanico  <i>Pneumatic to mechanical conversion kit</i>  <i>Kit de commutation de pneumatique à mécanique</i></p>	VS0863854	1
<p><b>Set completo ricambi</b>  <b>Complete set spare parts - Set completo ricambi (1+2+3+4)</b></p>			VS0863859	1
⑤		<p>Guarnizione per valvola  <i>Washer for outlet valve</i>  <i>Joint de mécanisme</i></p>	VS0801017	10
⑥		<p>Tubo flessibile 3/8"x3/8" Winner  <i>3/8"x3/8" Winner flexible pipe</i>  <i>Tuyau flexible 3/8"x3/8" Winner</i></p>	VS0863118	1
⑦		<p>Blocco centrale dal 2008 al 2016  <i>Central block from 2008 to 2016</i>  <i>Bloc central de 2008 à 2016</i></p>	VS0863120	1
⑧		<p>Blocco centrale dal 2004 al 2007  <i>Central block from 2004 to 2007</i>  <i>Bloc central de 2004 à 2007</i></p>	VS0863112	1
⑨		<p>Gancio blocca galleggiante  <i>Hook for securing float valve</i>  <i>Tige de blocage robinet flotteur</i></p>	VS0820111	1
⑩		<p>Kit tubo di risciacquo per Winner  <i>Flush pipe kit for Winner</i>  <i>Kit tube de descente Winner</i></p>	VS0863155	1
⑪		<p>Guarnizione a due labbra per tubo  <i>2-lip seal for pipe</i>  <i>Joint en deux lèvres pour tuyau</i></p>	VS0820119	1



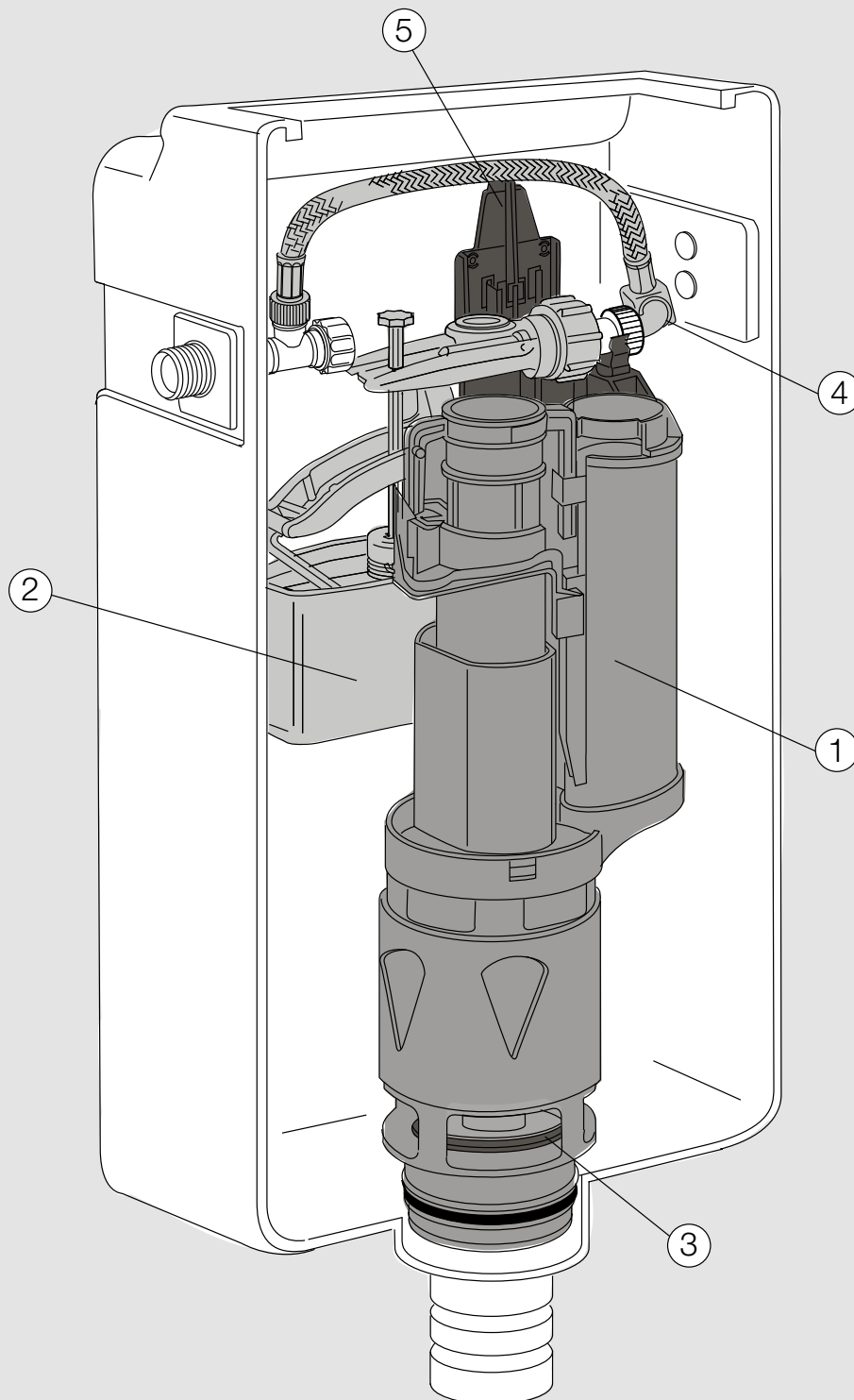



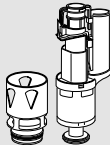
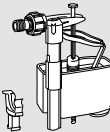

2004-2016

COD.





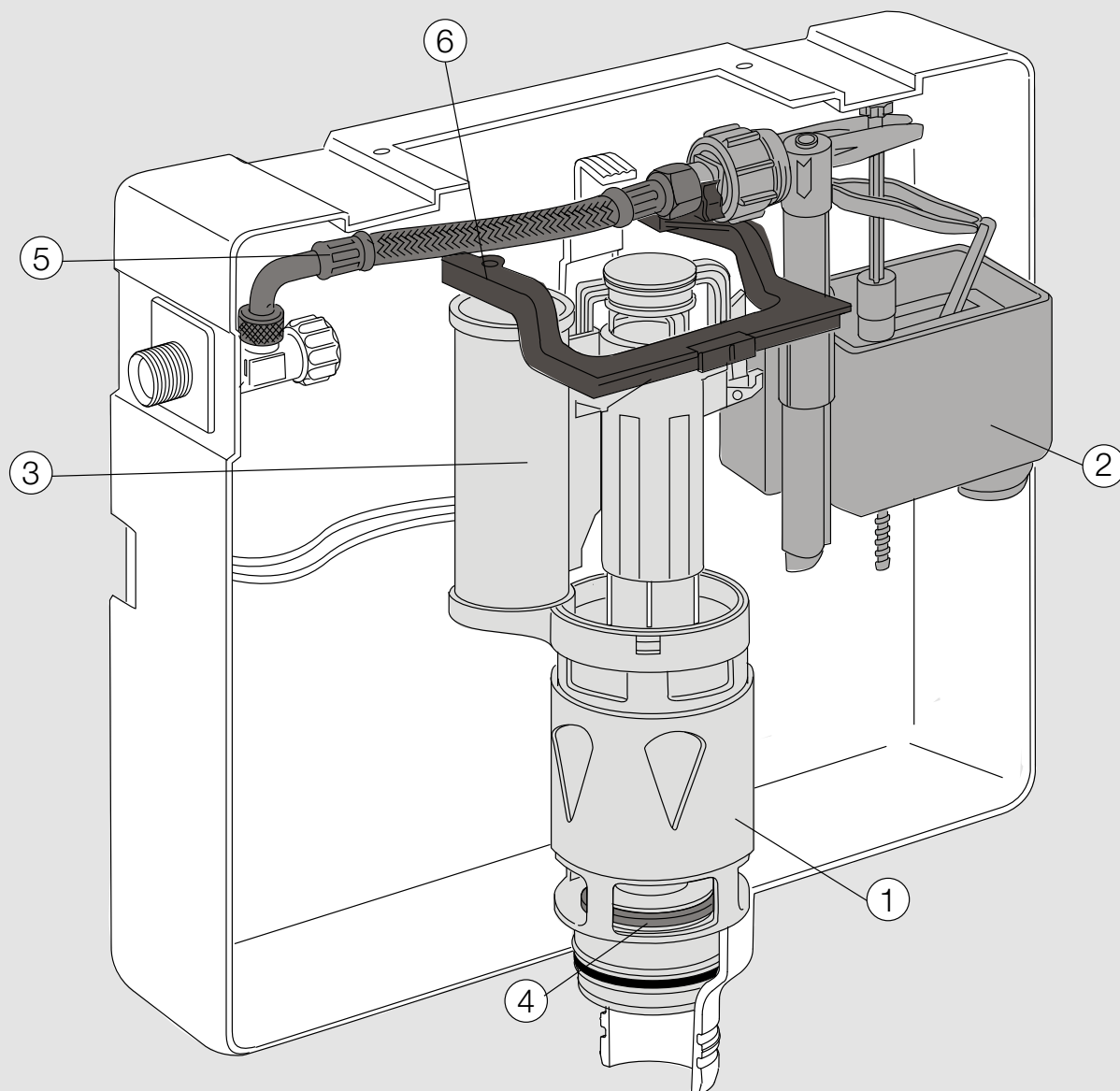



①		Kit valvola dal 2004 al 2016 <i>Valve kit from 2004 to 2016</i> <i>Kit vanne de 2004 à 2016</i>	VS0865801	1
②		Kit galleggiante dal 2004 al 2016 <i>Float valve kit from 2004 to 2016</i> <i>Kit flotteur de 2004 à 2016</i>	VS0865803	1
<b>Set completo ricambi - Complete set spare parts - Set completo ricambi (1+2)</b>			<b>VS0865811</b>	<b>1</b>
③		Guarnizione per valvola <i>Washer for outlet valve</i> <i>Joint de mécanisme</i>	VS0801017	10
④		Tubo flessibile 3/8"x3/8" <i>3/8"x3/8" flexible pipe</i> <i>Tube flexible 3/8"x3/8"</i>	VS0865128	1
⑤		Blocco centrale <i>Central block</i> <i>Bloc central</i>	VS0865112	1
⑥		Guarnizione a due labbra per tubo <i>2-lip seal for pipe</i> <i>Joint en deux lèvres pour tuyau</i>	VS0820119	1

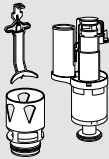
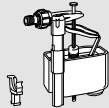

2004-2016

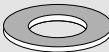



COD.

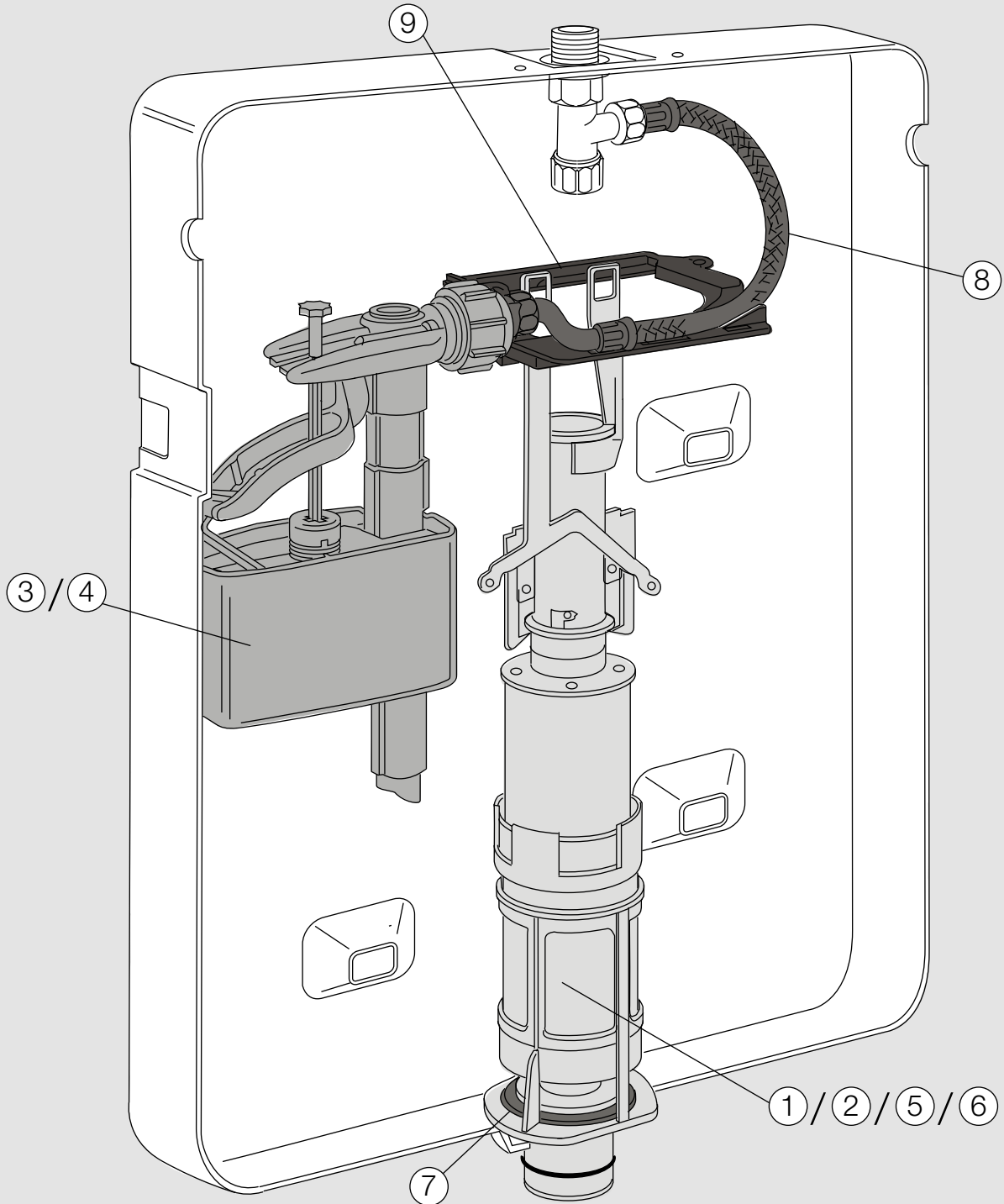

①		Kit valvola dal 2004 al 2016 <i>Valve kit from 2004 to 2016</i> <i>Kit vanne de 2004 à 2016</i>	VS0864801	1
②		Kit galleggiante dal 2004 al 2016 <i>Float valve kit from 2004 to 2016</i> <i>Kit flotteur de 2004 à 2016</i>	VS0864804	1
③		Kit pneumatico <i>Pneumatic kit</i> <i>Kit pneumatique</i>	VS0863160	1
<b>Set completo ricambi</b> <b>Complete set spare parts - Set completo ricambi (1+2+3)</b>			<b>VS0864811</b>	<b>1</b>
④		Guarnizione per valvola <i>Washer for outlet valve</i> <i>Joint de mécanisme</i>	VS0801017	10
⑤		Tubo flessibile 3/8"x3/8" Evolut <i>3/8"x3/8" Evolut flexible pipe</i> <i>Tube flexible 3/8"x3/8" Evolut</i>	VS0864118	1
⑥		Blocco centrale <i>Central block</i> <i>Bloc central</i>	VS0864117	1
⑦		Guarnizione a due labbra per tubo <i>2-lip seal for pipe</i> <i>Joint en deux lèvres pour tuyau</i>	VS0820119	1

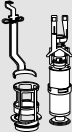
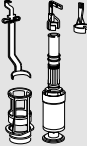
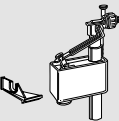
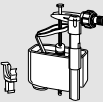
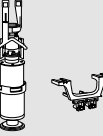
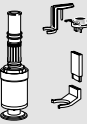

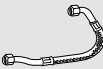
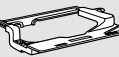
**1996-2014**
**COD.**

①		Kit valvola doppio scarico dal 200 al 2014 <i>Dual flush valve kit from 2000 to 2014</i> <i>Kit vanne double évacuation de 2000 à 2014</i>	VS0820802	1
②		Kit valvola scarico semplice dal 1996 al 2014 <i>Single flush valve kit from 1996 to 2014</i> <i>Kit vanne simple évacuation de 1996 à 2014</i>	VS0801802	1
③		Kit galleggiante dal 1996 al 2007 <i>Dual flush float valve kit from 1996 to 2007</i> <i>Kit flotteur de 1996 à 2007</i>	VS0820803	1
④		Kit galleggiante dal 2008 al 2014 <i>Dual flush float valve kit from 2008 to 2014</i> <i>Kit flotteur de 2008 à 2014</i>	VS0820804	1
⑤		Kit trasformazione meccanico doppio scarico <i>Dual flush mechanical conversion kit</i> <i>Kit transformation mécanique double évacuation</i>	VS0820805	1
⑥		Kit trasformazione da meccanico a pneumatico <i>Mechanical to pneumatic conversion kit</i> <i>Kit de commutation de mécanique à pneumatique</i>	VS0820806	1
⑦		Guarnizione per valvola <i>Washer for outlet valve</i> <i>Joint pour vanne</i>	VS0801017	10
⑧		Tubo flessibile con guarnizione incorporata <i>Flexible pipe with seal</i> <i>Tuyau flexible avec joint incorporé</i>	VS0820096	1
⑨		Blocco centrale dal 2008 al 2014 <i>Block central from 2008 to 2014</i> <i>Bloc central de 2008 à 2014</i>	VS0820260	1
⑩		Squadretta fissaggio galleggiante <i>Bracket for fixing float valve</i> <i>Élément de fixation flotteur</i>	VS0820378	1
⑪		Guarnizione a due labbra per tubo <i>2-lip seal for pipe</i> <i>Joint en deux lèvres pour tuyau</i>	VS0820119	1

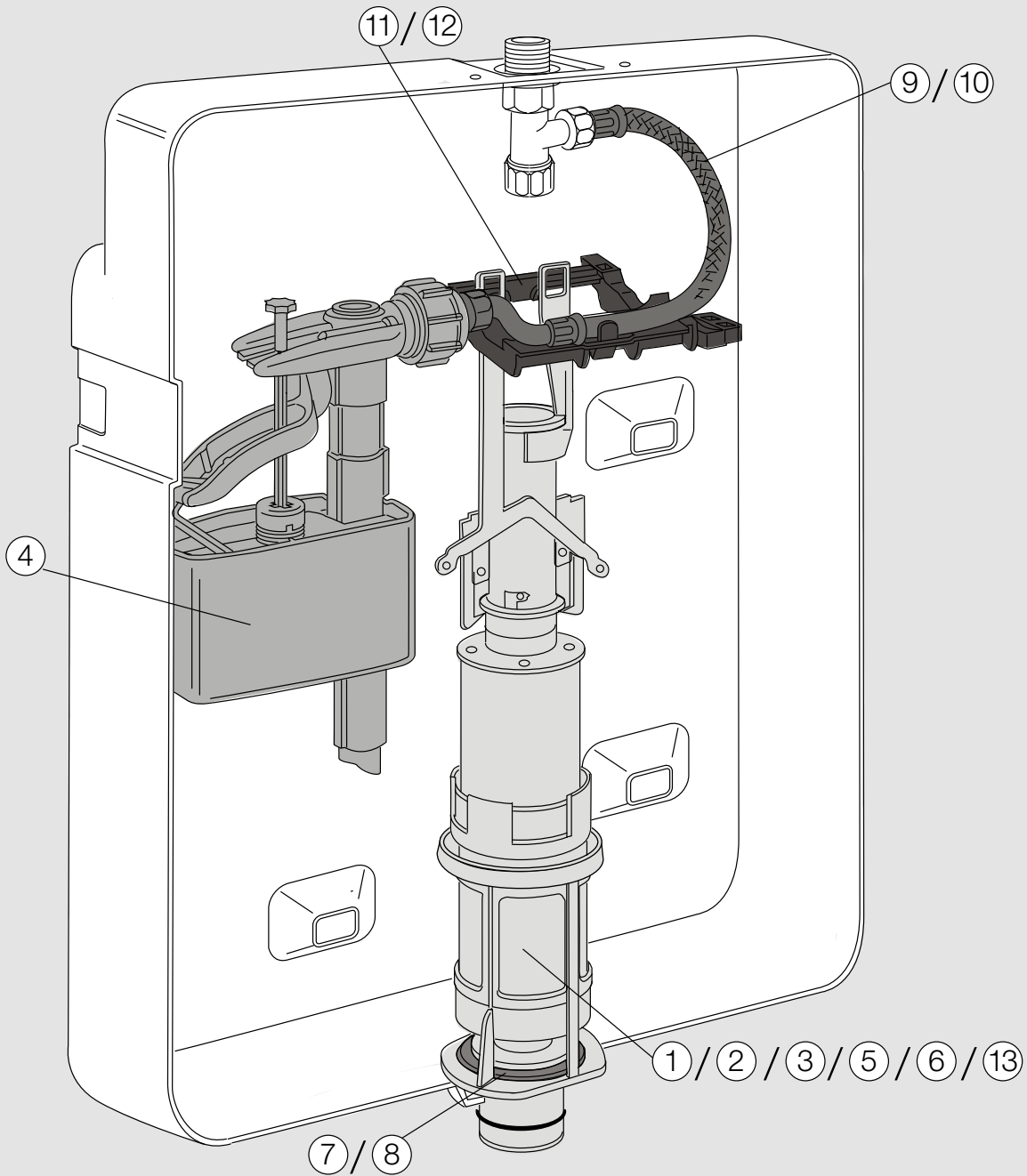

1996-2014

COD.



①



Kit valvola singolo scarico dal 1996 al 1999  
Single flush valve kit from 1996 to 1999  
Kit vanne simple évacuation de 1996 à 1999

VS0821802

1

②

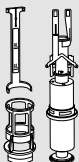

Kit valvola doppio scarico dal 2000 al 2009  
Dual flush valve kit from 2000 to 2009  
Kit vanne double évacuation de 2000 à 2009







VS0821801

1

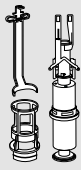
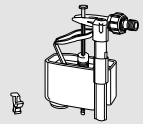
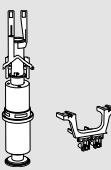
1996-2014

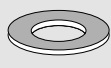
COD.

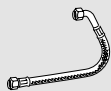
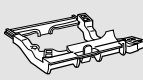
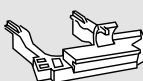
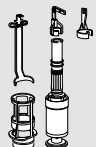



③		Kit valvola dal 2010 al 2014 Valve kit from 2010 to 2014 Kit vanne de 2010 à 2014	VS0821803	1
④		Kit galleggiante dal 1996 al 2014 Float valve kit from 1996 to 2014 Kit flotteur de 1996 à 2014	VS0821804	1
⑤		Kit trasformazione meccanico doppio scarico dal 2000 al 2014 Dual flush mechanical conversion kit from 2000 to 2014 Kit transformation mécanique double évacuation de 2000 à 2014	VS0821805	1
⑥		Kit pneumatico singolo scarico dal 2000 al 2014 Single flush pneumatic conversion kit from 2000 to 2014 Kit pneumatique simple évacuation de 2000 à 2014	VS0821807	1
<b>Set completo ricambi</b> <b>Complete set spare parts - Jeu complet de pièces de rechange (1+2+3+4+5+6)</b>			<b>VS0821813</b>	<b>1</b>
⑦		Guarnizione per valvola dal 1996 al 1999 Washer for outlet valve from 1996 to 1999 Joint pour vanne de 1996 à 1999	VS0801065	10
⑧		Guarnizione per valvola dal 2000 al 2014 Washer for outlet valve from 2000 to 2014 Joint pour vanne de 2000 à 2014	VS0801017	10
⑨		Tubo flessibile con guarnizione dal 1996 al 1999 Flexible hose with seal from 1996 to 1999 Tuyau flexible avec joint incorporé de 1996 à 1999	VS0820207	1
⑩		Tubo flessibile con guarnizione dal 2000 al 2014 Flexible hose with seal from 2000 to 2014 Tuyau flexible avec joint incorporé de 2000 à 2014	VS0820095	1
⑪		Blocco centrale dal 2010 al 2014 Central block from 2010 to 2014 Bloc central de 2010 à 2014	VS0863120	1
⑫		Blocco centrale dal 2000 al 2009 Central block from 2003 to 2009 Bloc central de 2000 à 2009	VS0820369	1
⑬		Kit valvola scarico semplice dal 2000 al 2014 Single flush valve kit from 2000 to 2014 Kit vanne simple évacuation de 2000 à 2014	VS0821808	1
⑭		Guarnizione a due labbra per tubo 2-lip seal for pipe Joint en deux lèvres pour tuyau	VS0820119	1

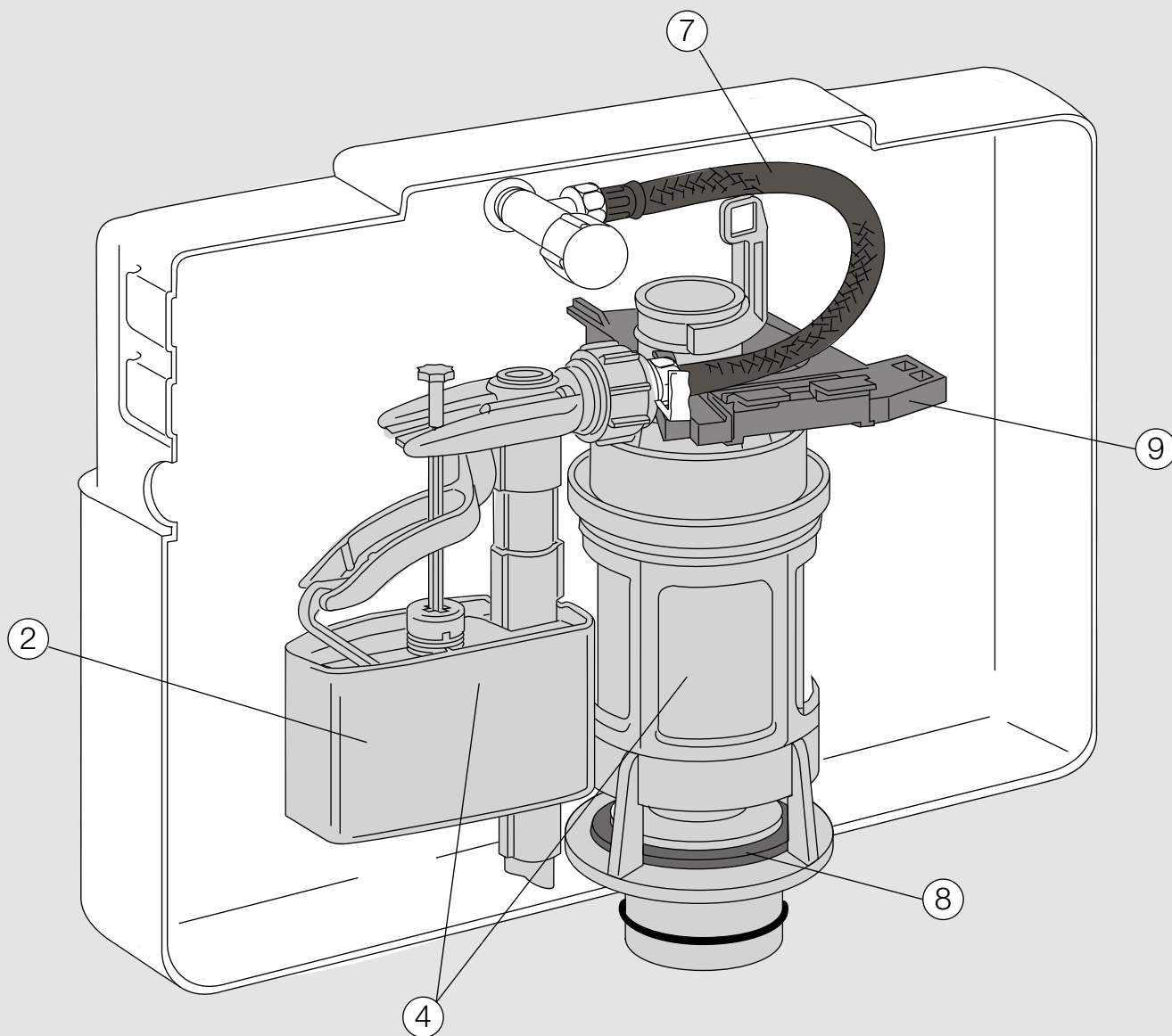



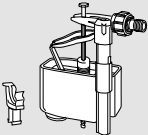



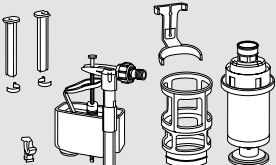

**1996-2003**
**COD.**

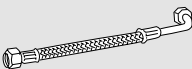

①		Kit valvola dal 1996 al 2003 <i>Valve kit from 1996 to 2003</i> <i>Kit vanne de 1996 à 2003</i>	VS0827801	1
②		Kit galleggiante dal 1996 al 2010 <i>Dual flush float valve kit from 1996 to 2010</i> <i>Kit flotteur de 1996 à 2010</i>	VS0820804	1
③		Kit leve <i>Lever kit</i> <i>Kit leviers</i>	VS0827808	1
<b>Set ricambi - Set spare parts - Jeu de pièces de rechange (1+2+3)</b>			<b>VS0827811</b>	<b>1</b>

**2003-2010**
**COD.**

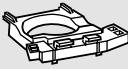

④		Kit cassetta dal 2003 al 2010 <i>Cistern kit from 2003 to 2010</i> <i>Kit cassetta dal 2003 al 2010</i>	VS0827802	1
⑤		Kit trasformazione da meccanico a pneumatico dal 2003 al 2010 <i>Mechanical to pneumatic conversion kit from 2003 to 2010</i> <i>Kit de commutation de mécanique à pneumatique de 2003 à 2010</i>	VS0822909	1
⑥		Kit leve <i>Lever kit</i> <i>Kit leviers</i>	VS0827808	1
⑦		Flessibile per modelli dal 2003 al 2010 <i>Flexible hose for models from 2003 to 2010</i> <i>Flexible pour modèles de 2003 à 2010</i>	VS0824111	1
<b>Set ricambi - Set spare parts - Jeu de pièces de rechange (4+5+6+7)</b>			<b>VS0827812</b>	<b>1</b>

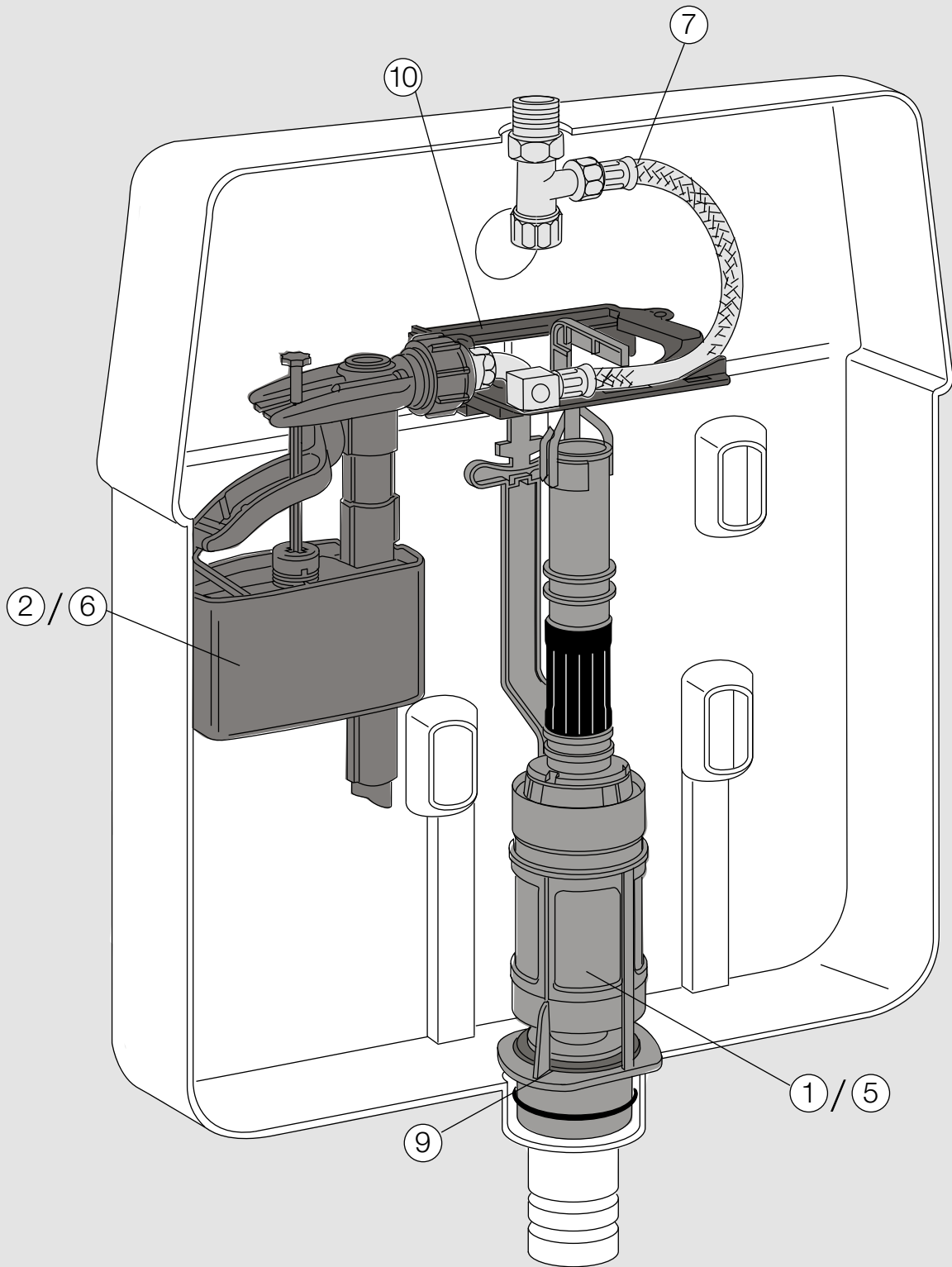
**Set completo ricambi**
**Complete set spare parts - Jeu complet de pièces de rechange (1+2+3+4+5+6+7)**
**VS0827813**
**1**



⑧		Guarnizione per valvola <i>Washer for outlet valve</i> <i>Joint pour vanne</i>	VS0801017	10
⑨		Blocco centrale <i>Central block</i> <i>Bloc central</i>	VS0823174	1
⑩		Guarnizione a due labbra per tubo <i>2-lip seal for pipe</i> <i>Joint en deux lèvres pour tuyau</i>	VS0820119	1

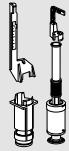
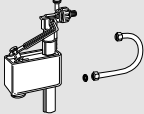
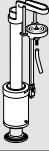

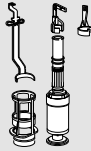
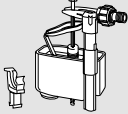
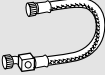

**1994-2008**
**COD.**

①		Kit valvola dal 1994 al 2008 <i>Valve kit from 1994 to 2008</i> <i>Kit vanne de 1994 à 2008</i>	VS0801801	1
②		Kit galleggiante dal 1994 al 2008 <i>Float valve kit from 1994 to 2008</i> <i>Kit flotteur de 1994 à 2008</i>	VS0801805	1
③		Kit pneumatico cassetta dal 1994 al 2008 <i>Pneumatic cistern kit from 1994 to 2008</i> <i>Kit pneumatique réservoir de 1994 à 2008</i>	VS0804660	1
④		Morsetto dal 1994 al 2008 <i>Grommet from 1994 to 2008</i> <i>Joint de 1994 à 2008</i>	VS0802016	10
<b>Set ricambi - Set spare parts - Jeu de pièces de rechange (1+2+3+4)</b>			<b>VS0801811</b>	<b>1</b>

**2009-2010**
**COD.**

⑤		Kit valvola dal 2009 al 2010 <i>Valve kit from 2009 to 2010</i> <i>Kit vanne de 2009 à 2010</i>	VS0801802	1
⑥		Kit galleggiante dal 2009 al 2010 <i>Float valve kit from 2009 to 2010</i> <i>Kit flotteur de 2009 à 2010</i>	VS0801806	1
⑦		Flessibile per modelli dal 2009 al 2010 <i>Flexible hose for models from 2009 to 2010</i> <i>Flexible pour modèles de 2009 à 2010</i>	VS0820096	1
⑧		Kit pneumatico cassetta dal 2009 al 2010 <i>Pneumatic cistern kit from 2009 to 2010</i> <i>Kit pneumatique réservoir de 2009 à 2010</i>	VS0822907	1
<b>Set ricambi - Set spare parts - Jeu de pièces de rechange (5+6+7+8)</b>			<b>VS0801812</b>	<b>1</b>

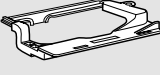
**Set completo ricambi**
**Complete set spare parts - Jeu complet de pièces de rechange (1+2+3+4+5+6+7+8)**
**VS0801813**
**1**

⑨		Guarnizione per valvola <i>Washer for outlet valve</i> <i>Joint pour vanne</i>	VS0801017	10
⑩		Blocco centrale <i>Central block</i> <i>Bloc central</i>	VS0820260	1
⑪		Squadretta fissaggio galleggiante <i>Bracket for fixing float valve</i> <i>Élément de fixation flotteur</i>	VS0801010 •	1

• Ad esaurimento. - Sell out. - Fin de stock.

**ACCESSORI E RICAMBI PER PRODUZIONI FINO AL 2015**

ACCESSORIES AND SPARE PARTS FOR PRODUCTION UP 2015

ACCESSOIRES ET PIÈCES DE RECHANGE POUR PRODUITS FINIS EN 2015

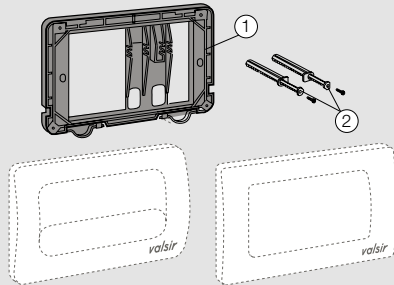

**VS08700XX - VS08703XX**  
**WINNER - TROPEA2 MECC****COD.**

① Controplacca completa di viti e distanziatori  
 Plate support frame complete with screws and spacers  
 Contreplaque, vis et entretoises VS0870847 1

② Distanziatori fissaggio placca  
 Spacer for attaching plate  
 Entretoises de fixation plaque VS0864166 1

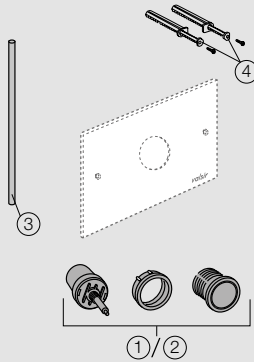
**VS08716XX - VS08706XX**  
**TROPEA3 - CUBIK - EVOLUT PNEU - WINNER - TROPEA2 PNEU****COD.**

① Kit pulsante scarico totale cromo lucido  
 Full flush button kit polished chrome  
 Kit poussoir de commande débit total - chromé brillant VS0875313 1

② Kit pulsante scarico totale cromo satinato  
 Full flush button kit satin chrome  
 Kit poussoir de commande débit total - chromé mat VS0875317 1

③ Tubo PVC bianco Ø 6x4 - 360 mm  
 White PVC pipe Ø 6x4 - 360 mm  
 Tube PVC blanc Ø 6x4 - 360 mm VS0804697 1

④ Distanziatori fissaggio placca  
 Spacer for attaching plate  
 Entretoises de fixation plaque VS0864166 1

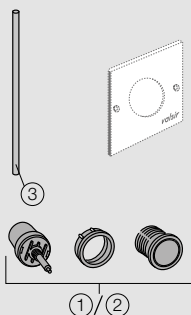
**VS08723XX****COD.**

① Kit pulsante scarico totale cromo lucido  
 Full flush button kit polished chrome  
 Kit poussoir de commande débit total - chromé brillant VS0875313 1

② Kit pulsante scarico totale cromo satinato  
 Full flush button kit satin chrome  
 Kit poussoir de commande débit total - chromé mat VS0875317 1

⑤ Tubo PVC bianco Ø 6x4 - 360 mm  
 White PVC pipe Ø 6x4 - 360 mm  
 Tube PVC blanc Ø 6x4 - 360 mm VS0804697 1

**VS08285XX-VS0828801-VS08280XX-VS0828301**  
**RIOS - ANGEL MECC**

**COD.**



	<p>① Controplacca completa di viti e distanziatori  <i>Plate support frame complete with screws and spacers</i>  <i>Contreplaque, vis et entretoises</i></p>	<p>VS0828548 1</p>
	<p>② Kit di prolungamento fissaggio placca due quantità  <i>Extension kit for fixing dual flush plate</i>  <i>Kit de rallonge fixation plaque deux quantités</i></p>	<p>VS0800136 1</p>
	<p>③ Kit di prolungamento fissaggio placca  <i>Extension kit for fixing plate</i>  <i>Kit de rallonge fixation plaque</i></p>	<p>VS0820222 1</p>
	<p>④ Vite di comando scarico totale  <i>Screw for push plate, total flush</i>  <i>Vis de commande évacuation totale</i></p>	<p>VS0820110 1</p>
	<p>⑤ Vite movimento 1/2 scarico  <i>Movement screw for 1/2 flush</i>  <i>Vis de mouvement 1/2 évacuation</i></p>	<p>VS0820367 1</p>
	<p>⑥ Distanziatori fissaggio placca  <i>Spacer for attaching plate</i>  <i>Entretoises de fixation plaque</i></p>	<p>VS0820167 1</p>
	<p>⑦ Molla  <i>Spring</i>  <i>Ressort</i></p>	<p>VS0822127 1</p>
	<p>⑧ Supporto con anello di regolazione fissaggio  <i>Support with adjustment ring fixing</i>  <i>Support avec bague de réglage fixation</i></p>	<p>VS0820169 1</p>

## ACCESSORI E RICAMBI PER PRODUZIONI FINO AL 2015

ACCESSORIES AND SPARE PARTS FOR PRODUCTION UP 2015  
ACCESSOIRES ET PIÈCES DE RECHANGE POUR PRODUITS FINIS EN 2015

 CASSETTE  FLUSHCISTERNS  RESERVOIRDECHASSE

### VS08220XX

RIOS - ANGEL MECC

COD.

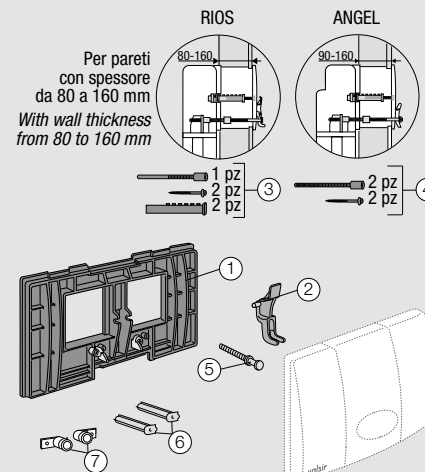

 <p>Per pareti con spessore da 80 a 160 mm With wall thickness from 80 to 160 mm</p>	①	Controplacca con nottolini Plate support frame with pawls Contreplaque avec cliquets	VS0804103	1
	②	Leva comando placca Lever for push plate Levier commande plaque	VS0822118	1
	③	Kit di prolungamento fissaggio placca scarico semplice Extension kit for fixing plate single flush Kit de rallonge fixation plaque simple évacuation	VS0800135	1
	④	Kit di prolungamento fissaggio placca Extension kit for fixing plate Kit de rallonge fixation plaque	VS0820218	1
	⑤	Vite di comando scarico totale Screw for push plate, total flush Vis de commande évacuation totale	VS0820110	1
	⑥	Distanziatori fissaggio placca Spacer for attaching plate Entretoises de fixation plaque	VS0820167	1
	⑦	Supporto con anello di regolazione fissaggio Support with adjustment ring fixing Support avec bague de réglage fixation	VS0820169	1

### VS08040XX

MEDUSA MECC

COD.

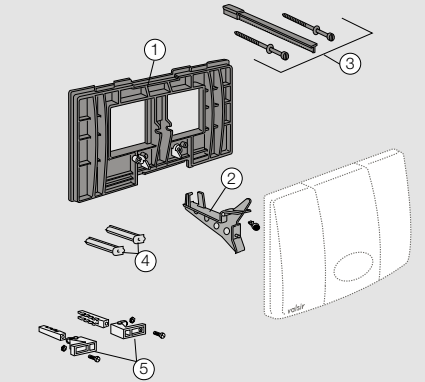

	①	Controplacca con nottolini Plate support frame with pawls Contreplaque avec cliquets	VS0804103	1
	②	Leva comando placca Lever for push plate Levier commande plaque	VS0804050	1
	③	Kit di prolungamento fissaggio Extension kit for fixing plate Kit de rallonge fixation	VS0801068	1
	④	Distanziatori fissaggio placca Spacer for attaching plate Entretoises de fixation plaque	VS0820192	1
	⑤	Elementi di fissaggio placca (2 pz) Plate fasteners (2 pcs) Éléments de fixation plaque (2 pièces)	VS0801025	1

**VS08234XX**  
**EGEA MECC**

**COD.**







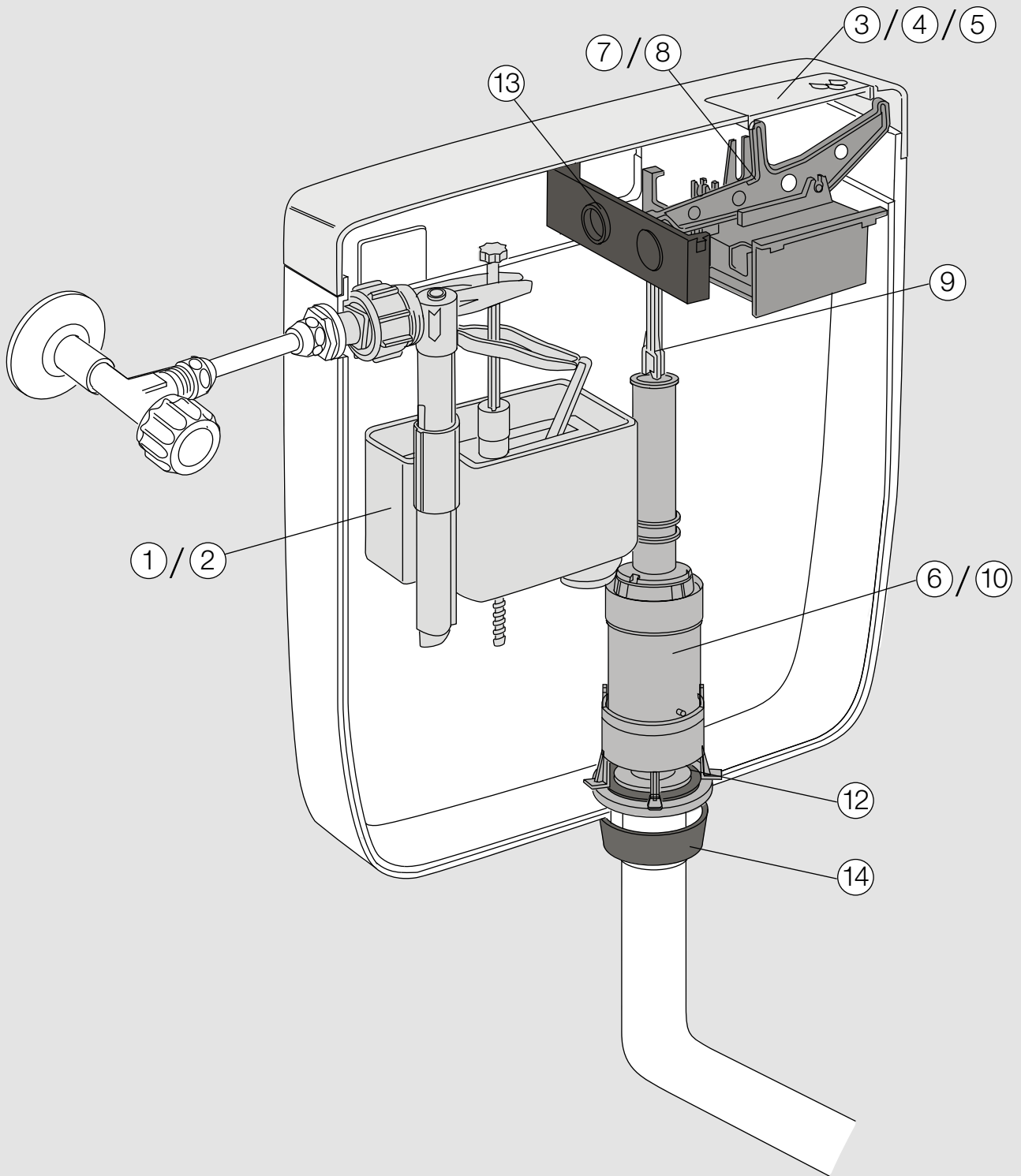

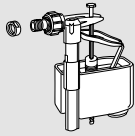
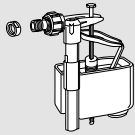
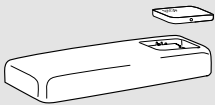
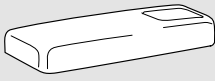
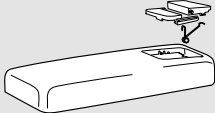

	①	Leva comando placca <i>Lever for push plate</i> <i>Levier commande plaque</i>	VS0823685	1
	②	Leva di movimento <i>Control lever</i> <i>Levier de mouvement</i>	VS0823021	1
	③	Vite movimento comando <i>Screw for control mechanism</i> <i>Vis de mouvement</i>	VS0823020	1
	④	Kit di prolungamento fissaggio <i>Extension kit for fixing plate</i> <i>Kit de rallonge fixation</i>	VS0820218	1
	⑤	Distanziatori fissaggio placca <i>Spacer for attaching plate</i> <i>Entretoises de fixation plaque</i>	VS0820191	1

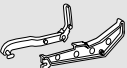
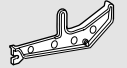

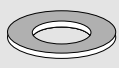
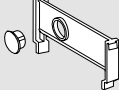

**Ricambi - Spare parts - Pièces de rechange**
**COD.**

①		Rubinetto galleggiante 3/8" Mono 3/8" Mono float valve Robinet flotteur 3/8" mono	VS0800218	1
②		Rubinetto galleggiante 1/2" Mono 1/2" Mono float valve Robinet flotteur 1/2" mono	VS0800219	1
③		Coperchio per cassetta Corallo con pulsante dal 1999 al 2012 Lid for Corallo cistern with single flush button from 1999 to 2012 Couvercle avec poussoir pour réservoir Corallo 1999-2012	VS0814401	1
④		Coperchio cassetta Corallo con coperchio fisso PNEUS Lid for Corallo pneumatic cistern with fixed cap Couvercle pour réservoir Corallo avec partie fixe pour pneumatique	VS0814701	1
⑤		Coperchio per cassetta Corallo con 2 pulsanti bianco Lid dual flush buttons for Corallo cistern. White Couvercle avec 2 poussoirs pour réservoir Corallo blanc	VS0814201	1
⑥		Valvola di scarico semplice dal 1999 al 2012 Single flush outlet valve from 1999 to 2012 Mécanisme simple debit 1999-2012	VS0810251	1
⑦		Kit leve meccanico Kit mechanic levers Kit mécanique leviers	VS0810160	1
⑧		Leva scarico semplice Single flush levers Levier évacuation partielle	VS0810165	1
⑨		Ancorina Anchor Ancre	VS0810108	1
⑩		Valvola di scarico due quantità completa di ancorina dal 1999 al 2012 Dual flush outlet valve, with anchor from 1999 to 2012 Vanne d'évacuation deux quantités avec ancre de 1999 à 2012	VS0810156	1
⑪		Meccanismo pneumatico per Corallo Corallo pneumatic mechanism Mécanisme pneumatique Corallo	VS0804505	1
⑫		Guarnizione per valvola Seal for outlet valve Joint de mécanisme	VS0801017	10
⑬		Traversa porta rubinetto galleggiante Crosspiece for holding float valve Traverse porte robinet flotteur	VS0850402	1
⑭		Dadone filettato completo di anello e guarnizione Large threaded nut with ring and seal Ecrou fileté avec anneau et joint	VS0810113	1

# LISTA ARTICOLI

## LIST OF PRODUCTS

## LISTE DES ARTICLES

<b>COD.</b>	<b>Pag.</b>	<b>COD.</b>	<b>Pag.</b>	<b>COD.</b>	<b>Pag.</b>	<b>COD.</b>	<b>Pag.</b>	<b>COD.</b>	<b>Pag.</b>	<b>COD.</b>	<b>Pag.</b>
VS0334021	111	VS0801801	183	VS0804001	157	VS0810199	115	VS0820096	177	VS0823438	159
VS0335001	111	VS0801802	177	VS0804003	157	VS0810251	147	VS0820110	185	VS0823685	187
VS0335003	111	VS0801805	183	VS0804005	157	VS0810258	149	VS0820111	169	VS0823801	159
VS0337001	113	VS0801806	183	VS0804017	157	VS0810261	149	VS0820118	128	VS0823835	159
VS0354001	90	VS0801811	183	VS0804021	157	VS0810291	143	VS0820119	119	VS0823837	159
VS0364001	87	VS0801812	183	VS0804035	157	VS0810293	141	VS0820163	119	VS0823838	159
VS0364003	87	VS0801813	183	VS0804037	157	VS0810521	139	VS0820167	185	VS0823900	160
VS0364006	87	VS0802009	134	VS0804038	157	VS0810522	139	VS0820169	185	VS0824111	181
VS0364008	87	VS0802016	110	VS0804050	186	VS0810998	115	VS0820191	187	VS0824135	135
VS0364015	87	VS0802135	66	VS0804103	186	VS0814201	189	VS0820192	186	VS0825021	134
VS0364052	87	VS0802137	66	VS0804501	157	VS0814401	189	VS0820207	179	VS0825023	93
VS0364059	87	VS0802235	66	VS0804505	143	VS0814701	189	VS0820218	186	VS0825028	93
VS0364090	87	VS0802237	66	VS0804535	157	VS0815001	108	VS0820222	185	VS0825030	134
VS0364100	87	VS0802301	71	VS0804537	157	VS0815035	108	VS0820224	135	VS0825031	134
VS0364111	87	VS0802335	71	VS0804621	133	VS0815064	112	VS0820260	177	VS0825051	93
VS0366001	90	VS0802337	71	VS0804622	133	VS0815071	109	VS0820367	185	VS0825053	93
VS0366002	90	VS0802338	71	VS0804623	133	VS0815083	112	VS0820369	179	VS0825056	93
VS0366003	90	VS0802401	71	VS0804625	133	VS0815101	108	VS0820378	177	VS0825058	93
VS0366090	89	VS0802435	71	VS0804628	133	VS0815103	108	VS0820802	177	VS0825302	78
VS0366113	89	VS0802437	71	VS0804629	133	VS0815105	108	VS0820803	177	VS0825402	78
VS0366125	89	VS0802455	70	VS0804635	133	VS0815117	108	VS0820804	177	VS0825601	95
VS0366133	89	VS0802535	164	VS0804660	143	VS0815201	108	VS0820805	177	VS0826065	136
VS0366139	91	VS0802537	164	VS0804697	126	VS0815203	108	VS0820806	177	VS0826066	136
VS0366149	91	VS0802601	75	VS0804698	126	VS0815301	108	VS0821801	178	VS0826068	136
VS0367001	90	VS0802635	75	VS0804801	70	VS0815303	108	VS0821802	178	VS0826072	136
VS0367003	90	VS0802701	75	VS0804811	132	VS0815313	108	VS0821803	179	VS0826101	95
VS0368001	88	VS0802735	75	VS0804824	132	VS0815317	108	VS0821804	179	VS0827801	181
VS0368003	88	VS0802835	164	VS0804901	70	VS0815401	108	VS0821805	179	VS0827802	181
VS0370001	88	VS0802837	164	VS0804902	132	VS0815405	108	VS0821807	179	VS0827808	181
VS0370002	88	VS0802935	164	VS0804911	132	VS0815409	108	VS0821808	179	VS0827811	181
VS0370003	88	VS0802937	164	VS0805128	135	VS0815417	108	VS0821813	179	VS0827812	181
VS0372001	89	VS0803001	76	VS0805150	95	VS0815421	108	VS0822001	156	VS0827813	181
VS0372002	89	VS0803003	76	VS0805153	169	VS0815501	108	VS0822003	156	VS0828001	155
VS0372003	89	VS0803005	76	VS0805350	92	VS0815601	109	VS0822005	156	VS0828003	155
VS0374001	87	VS0803017	76	VS0805355	92	VS0815603	109	VS0822015	113	VS0828005	155
VS0374003	87	VS0803035	76	VS0810078	139	VS0815801	112	VS0822017	156	VS0828017	155
VS0391320	111	VS0803037	76	VS0810106	149	VS0815999	110	VS0822035	156	VS0828021	155
VS0564190	91	VS0803038	76	VS0810107	147	VS0816001	110	VS0822038	156	VS0828037	155
VS0587001	91	VS0803111	74	VS0810108	189	VS0816003	110	VS0822118	186	VS0828137	155
VS0700071	91	VS0803145	74	VS0810113	189	VS0816005	110	VS0822127	126	VS0828201	75
VS0700073	92	VS0803147	74	VS0810114	114	VS0816101	99	VS0822201	156	VS0828301	155
VS0700075	92	VS0803201	75	VS0810115	113	VS0816103	99	VS0822301	156	VS0828501	154
VS0700098	111	VS0803202	136	VS0810148	147	VS0816105	99	VS0822337	156	VS0828503	154
VS0700099	111	VS0803203	75	VS0810156	189	VS0816151	99	VS0822907	183	VS0828535	154
VS0800135	186	VS0803205	75	VS0810157	147	VS0816153	99	VS0822909	181	VS0828537	154
VS0800136	185	VS0803217	75	VS0810159	143	VS0817001	109	VS0823020	187	VS0828548	185
VS0800218	139	VS0803235	75	VS0810160	189	VS0817003	109	VS0823021	187	VS0828601	154
VS0800219	139	VS0803237	75	VS0810163	151	VS0817401	139	VS0823174	181	VS0828635	154
VS0801010	183	VS0803238	75	VS0810164	151	VS0817403	139	VS0823201	159	VS0828637	154
VS0801017	141	VS0803511	74	VS0810165	189	VS0817404	139	VS0823235	159	VS0828801	154
VS0801025	186	VS0803545	74	VS0810166	147	VS0817405	139	VS0823401	159	VS0830001	103
VS0801065	179	VS0803547	74	VS0810181	115	VS0817410	139	VS0823435	159	VS0830005	103
VS0801068	186	VS0803901	74	VS0810186	165	VS0820095	179	VS0823437	159	VS0830501	103

<b>COD.</b>	<b>Pag.</b>	<b>COD.</b>	<b>Pag.</b>	<b>COD.</b>	<b>Pag.</b>	<b>COD.</b>	<b>Pag.</b>	<b>COD.</b>	<b>Pag.</b>	<b>COD.</b>	<b>Pag.</b>
VS0831101	103	VS0853058	12	VS0857058	85	VS0866603	119	VS0869211	43	VS0870935	73
VS0831401	151	VS0853101	18	VS0857066	86	VS0866625	119	VS0869235	43	VS0870937	73
VS0831501	107	VS0853111	17	VS0858002	4	VS0866641	125	VS0869237	43	VS0871003	161
VS0831601	103	VS0853121	18	VS0858021	4	VS0866690	119	VS0869245	43	VS0871017	161
VS0831701	103	VS0853145	16	VS0858052	4	VS0866692	167	VS0869247	43	VS0871301	41
VS0831901	103	VS0853151	18	VS0858102	6	VS0866693	119	VS0869291	43	VS0871335	41
VS0832001	103	VS0853161	17	VS0858121	6	VS0866694	167	VS0869295	43	VS0871337	41
VS0833701	106	VS0853175	16	VS0858152	6	VS0866695	126	VS0869297	43	VS0871348	126
VS0834001	105	VS0853201	22	VS0858211	8	VS0866696	119	VS0869301	44	VS0871349	127
VS0834501	106	VS0853211	21	VS0858221	8	VS0866697	48	VS0869311	44	VS0871401	73
VS0834901	105	VS0853221	22	VS0858255	8	VS0866699	167	VS0869335	44	VS0871435	73
VS0835001	104	VS0853245	20	VS0858302	5	VS0866704	94	VS0869337	44	VS0871437	73
VS0835301	104	VS0853251	22	VS0858303	7	VS0866790	121	VS0869345	44	VS0871501	42
VS0835901	104	VS0853261	21	VS0858311	9	VS0866792	119	VS0869347	44	VS0871503	42
VS0836001	104	VS0853275	20	VS0858352	5	VS0866794	119	VS0869391	44	VS0871517	42
VS0837501	104	VS0853302	15	VS0858353	7	VS0866796	121	VS0869395	44	VS0871535	42
VS0837601	104	VS0853311	19	VS0858355	9	VS0866801	169	VS0869397	44	VS0871537	42
VS0838001	146	VS0853321	23	VS0858401	10	VS0866803	169	VS0869401	45	VS0871548	126
VS0838003	146	VS0853331	27	VS0858451	10	VS0866805	169	VS0869402	45	VS0871549	126
VS0838005	146	VS0853352	15	VS0860050	143	VS0866811	169	VS0869404	45	VS0871550	127
VS0838009	146	VS0853361	19	VS0860901	102	VS0866890	123	VS0869411	45	VS0871637	161
VS0838013	146	VS0853371	23	VS0861901	102	VS0866892	123	VS0869412	45	VS0871735	46
VS0838017	146	VS0853381	27	VS0862901	102	VS0866894	123	VS0869414	45	VS0871737	46
VS0838021	146	VS0853401	26	VS0863112	171	VS0866896	123	VS0869435	45	VS0872204	72
VS0838401	149	VS0853411	25	VS0863118	171	VS0866992	121	VS0869437	45	VS0872206	68
VS0838501	147	VS0853421	26	VS0863120	171	VS0866994	121	VS0869445	45	VS0872235	66
VS0838591	147	VS0853445	24	VS0863155	171	VS0867032	84	VS0869447	45	VS0872237	66
VS0838801	148	VS0853451	26	VS0863160	171	VS0867034	84	VS0869491	45	VS0872335	164
VS0838805	148	VS0853461	25	VS0863509	121	VS0867132	86	VS0869495	45	VS0872337	164
VS0838809	148	VS0853475	24	VS0863565	123	VS0867134	86	VS0869497	45	VS0872501	64
VS0838813	148	VS0855002	31	VS0863851	171	VS0867655	137	VS0870001	162	VS0872535	64
VS0838817	148	VS0855004	30	VS0863854	171	VS0868172	93	VS0870035	162	VS0872537	64
VS0838821	148	VS0855052	31	VS0863855	171	VS0868239	94	VS0870037	162	VS0872601	41
VS0839081	143	VS0855054	30	VS0863859	171	VS0868278	136	VS0870230	65	VS0872635	41
VS0839088	147	VS0855201	33	VS0863860	94	VS0868284	121	VS0870235	46	VS0872637	41
VS0840901	101	VS0855211	32	VS0863861	94	VS0868301	165	VS0870237	46	VS0872801	42
VS0842901	101	VS0855251	33	VS0864117	175	VS0868310	165	VS0870301	162	VS0872835	42
VS0844001	101	VS0855261	32	VS0864118	175	VS0868613	135	VS0870337	162	VS0872837	42
VS0846001	100	VS0855401	35	VS0864166	126	VS0868625	96	VS0870401	73	VS0874011	124
VS0846100	141	VS0855411	34	VS0864801	175	VS0868732	83	VS0870435	73	VS0874012	124
VS0846101	100	VS0855451	35	VS0864804	175	VS0868749	128	VS0870437	73	VS0874013	124
VS0847001	100	VS0855461	34	VS0864811	175	VS0868830	137	VS0870501	64	VS0874015	124
VS0850021	143	VS0857002	80	VS0865112	173	VS0868832	137	VS0870503	64	VS0874016	125
VS0850022	145	VS0857004	80	VS0865128	173	VS0868834	137	VS0870535	64	VS0874022	125
VS0850050	145	VS0857006	79	VS0865148	76	VS0868901	47	VS0870537	64	VS0875001	67
VS0850100	143	VS0857008	79	VS0865801	173	VS0868911	47	VS0870637	163	VS0875011	69
VS0850402	189	VS0857012	82	VS0865803	173	VS0868921	48	VS0870735	65	VS0875035	67
VS0853002	14	VS0857013	82	VS0865811	173	VS0868930	48	VS0870737	65	VS0875037	67
VS0853004	13	VS0857014	81	VS0866112	169	VS0868951	83	VS0870835	65	VS0875047	69
VS0853008	12	VS0857016	81	VS0866116	169	VS0868953	83	VS0870837	65	VS0875109	130
VS0853022	14	VS0857022	83	VS0866118	169	VS0869001	102	VS0870847	184	VS0875110	130
VS0853052	14	VS0857032	84	VS0866163	169	VS0869101	102	VS0870848	128	VS0875208	68
VS0853054	13	VS0857056	85	VS0866580	119	VS0869201	43	VS0870901	73	VS0875297	130

**LISTA ARTICOLI**  
**LIST OF PRODUCTS**  
**LISTE DES ARTICLES**

  

<b>COD.</b>	<b>Pag.</b>	<b>COD.</b>	<b>Pag.</b>	<b>COD.</b>	<b>Pag.</b>	<b>COD.</b>	<b>Pag.</b>	<b>COD.</b>	<b>Pag.</b>	<b>COD.</b>	<b>Pag.</b>
VS0875298	130	VS0876301	56	VS0876833	59	VS0877347	51	VS0877967	55	VS0878603	59
VS0875305	130	VS0876303	56	VS0876835	59	VS0877348	52	VS0878001	61	VS0878605	59
VS0875307	130	VS0876305	56	VS0876837	59	VS0877351	51	VS0878003	61	VS0878607	59
VS0875309	130	VS0876307	56	VS0877001	49	VS0877352	53	VS0878005	61	VS0878621	60
VS0875311	130	VS0876311	57	VS0877003	49	VS0877353	51	VS0878007	61	VS0878623	60
VS0875313	128	VS0876313	57	VS0877005	49	VS0877354	53	VS0878011	60	VS0878625	60
VS0875315	128	VS0876315	57	VS0877007	49	VS0877355	51	VS0878013	60	VS0878627	60
VS0875317	128	VS0876317	57	VS0877011	49	VS0877356	53	VS0878015	60	VS0878801	59
VS0875319	128	VS0876321	57	VS0877013	49	VS0877357	51	VS0878017	60	VS0878803	59
VS0875321	131	VS0876323	57	VS0877015	49	VS0877358	53	VS0878021	61	VS0878805	59
VS0875323	131	VS0876325	57	VS0877017	49	VS0877361	52	VS0878023	61	VS0878807	59
VS0875324	131	VS0876327	57	VS0877021	50	VS0877362	53	VS0878025	61	VS0878811	59
VS0875325	131	VS0876331	56	VS0877023	50	VS0877363	52	VS0878027	61	VS0878813	59
VS0875327	131	VS0876333	56	VS0877025	50	VS0877364	53	VS0878033	61	VS0878815	59
VS0875328	131	VS0876335	56	VS0877027	50	VS0877365	52	VS0878035	61	VS0878817	59
VS0875329	130	VS0876337	56	VS0877031	50	VS0877366	53	VS0878037	61	VS0878821	60
VS0875331	130	VS0876341	57	VS0877033	50	VS0877367	52	VS0878041	62	VS0878823	60
VS0875332	130	VS0876343	57	VS0877035	50	VS0877368	53	VS0878043	62	VS0878825	60
VS0875333	130	VS0876345	57	VS0877037	50	VS0877601	49	VS0878045	62	VS0878827	60
VS0875335	130	VS0876347	57	VS0877041	51	VS0877603	49	VS0878047	62	VS0878851	62
VS0875337	130	VS0876351	56	VS0877043	51	VS0877605	49	VS0878051	62	VS0878852	62
VS0875338	130	VS0876353	56	VS0877045	51	VS0877607	49	VS0878053	62	VS0878853	62
VS0875339	130	VS0876355	56	VS0877047	51	VS0877611	49	VS0878055	62	VS0878854	62
VS0875341	130	VS0876357	56	VS0877051	51	VS0877613	49	VS0878057	62	VS0878855	62
VS0875501	67	VS0876601	58	VS0877053	51	VS0877615	49	VS0878061	60	VS0878856	62
VS0875511	69	VS0876603	58	VS0877055	51	VS0877617	49	VS0878063	60	VS0878857	62
VS0875535	67	VS0876605	58	VS0877057	51	VS0877621	50	VS0878065	60	VS0878858	62
VS0875537	67	VS0876607	58	VS0877301	49	VS0877623	50	VS0878067	60	VS0878860	54
VS0875547	69	VS0876611	58	VS0877303	49	VS0877625	50	VS0878301	61	VS0878861	54
VS0876001	56	VS0876613	58	VS0877305	49	VS0877627	50	VS0878303	61	VS0878862	54
VS0876003	56	VS0876615	58	VS0877307	49	VS0877631	50	VS0878305	61	VS0878863	54
VS0876005	56	VS0876617	58	VS0877311	49	VS0877633	50	VS0878307	61	VS0878864	54
VS0876007	56	VS0876621	58	VS0877313	49	VS0877635	50	VS0878311	60	VS0878865	54
VS0876011	57	VS0876623	58	VS0877315	49	VS0877637	50	VS0878313	60	VS0878866	54
VS0876013	57	VS0876625	58	VS0877317	49	VS0877641	51	VS0878315	60	VS0878867	54
VS0876015	57	VS0876627	58	VS0877321	50	VS0877643	51	VS0878317	60	VS0878868	54
VS0876017	57	VS0876631	59	VS0877323	50	VS0877645	51	VS0878321	61	VS0878869	54
VS0876021	57	VS0876633	59	VS0877325	50	VS0877647	51	VS0878323	61	VS0878870	54
VS0876023	57	VS0876635	59	VS0877327	50	VS0877651	51	VS0878331	61	VS0878871	54
VS0876025	57	VS0876637	59	VS0877331	50	VS0877653	51	VS0878333	61	VS0878872	63
VS0876027	57	VS0876801	58	VS0877332	52	VS0877655	51	VS0878335	61	VS0878873	63
VS0876031	56	VS0876803	58	VS0877333	50	VS0877657	51	VS0878337	61	VS0878874	63
VS0876033	56	VS0876805	58	VS0877334	52	VS0877901	55	VS0878345	62	VS0878875	63
VS0876035	56	VS0876807	58	VS0877335	50	VS0877903	55	VS0878347	62	VS0879001	63
VS0876037	56	VS0876811	58	VS0877336	52	VS0877905	55	VS0878351	62	VS0879003	63
VS0876041	57	VS0876813	58	VS0877337	50	VS0877907	55	VS0878353	62	VS0879005	63
VS0876043	57	VS0876815	58	VS0877338	52	VS0877931	55	VS0878355	62	VS0879007	63
VS0876045	57	VS0876817	58	VS0877341	51	VS0877933	55	VS0878357	62	VS0879011	63
VS0876047	57	VS0876821	58	VS0877342	52	VS0877935	55	VS0878361	60	VS0879013	63
VS0876051	56	VS0876823	58	VS0877343	51	VS0877937	55	VS0878363	60	VS0879015	63
VS0876053	56	VS0876825	58	VS0877344	52	VS0877961	55	VS0878365	60	VS0879017	63
VS0876055	56	VS0876827	58	VS0877345	51	VS0877963	55	VS0878367	60	VS0881153	83
VS0876057	56	VS0876831	59	VS0877346	52	VS0877965	55	VS0878601	59		

**LA GAMMA VALSIR  
THE VALSIR RANGE  
LA GAMME VALSIR**



**SISTEMI SCARICO  
WASTE SYSTEMS  
SYSTEME EVACUATION**

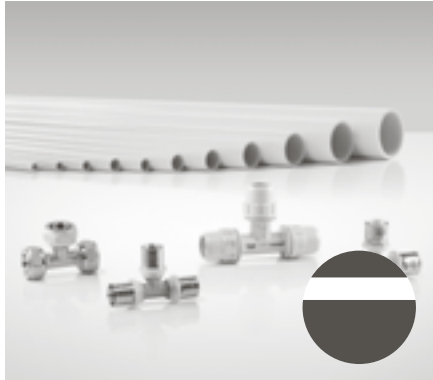

**SISTEMI ADDUZIONE  
SUPPLY SYSTEMS  
SYSTEME ALIMENTATION**

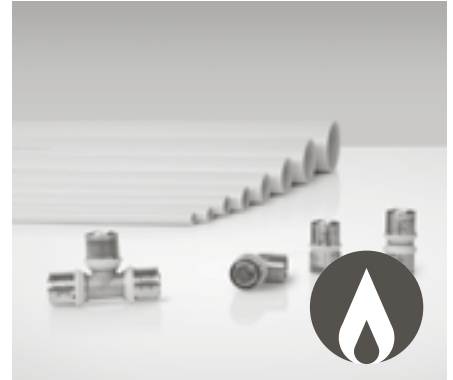

**SISTEMI GAS  
GAS SYSTEMS  
SYSTEME GAZ**



**SISTEMI RISCIAQUO  
FLUSH SYSTEMS  
RESERVOIR DE CHASSE**



**SISTEMI BAGNO  
BATHROOM SYSTEMS  
SYSTEME SALLE DE BAIN**



**SIFONI  
TRAPS  
SIPHON**

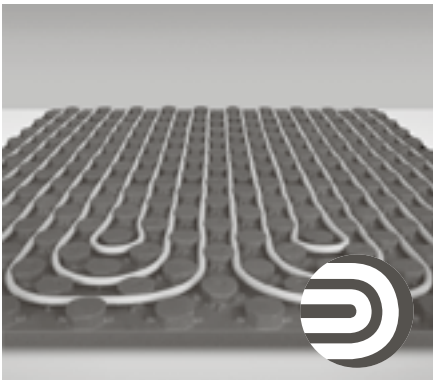

**SISTEMI RADIANTI  
RADIANT SYSTEMS  
SYSTEME PANCHER CHAUFFANT**

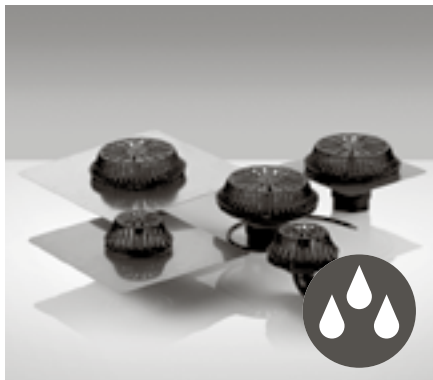

**SISTEMI DRENAGGIO  
DRAINAGE SYSTEMS  
SYSTEME EVACUATION PLUVIALE**



**ACADEMY**



**VALSIR S.p.A.**  
Località Merlaro, 2  
25078 Vestone (BS) - Italy  
Tel. +39 0365 877.011  
Fax +39 0365 81.268  
e-mail: valsir@valsir.it

**www.valsir.it**



Soggetta all'attività di direzione e coordinamento ex art. 2497 bis C.C. da parte di Fondital Group S.p.A. - Codice Fiscale 02075160172

**MADE IN ITALY**



**valsir®**  
QUALITY FOR PLUMBING

